

READ AND SAVE THESE INSTRUCTIONS

# JEM™ GLACIATOR™ DYNAMIC

user manual



# Dimensions

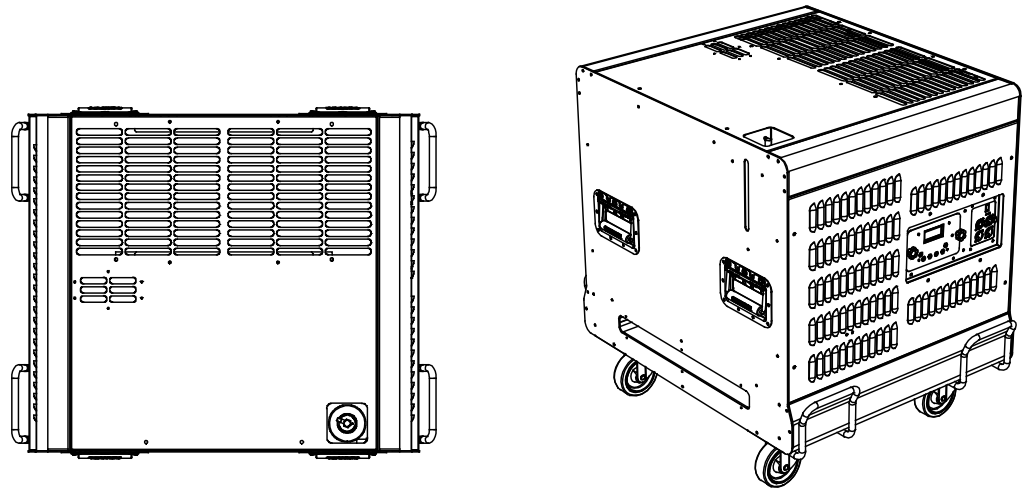
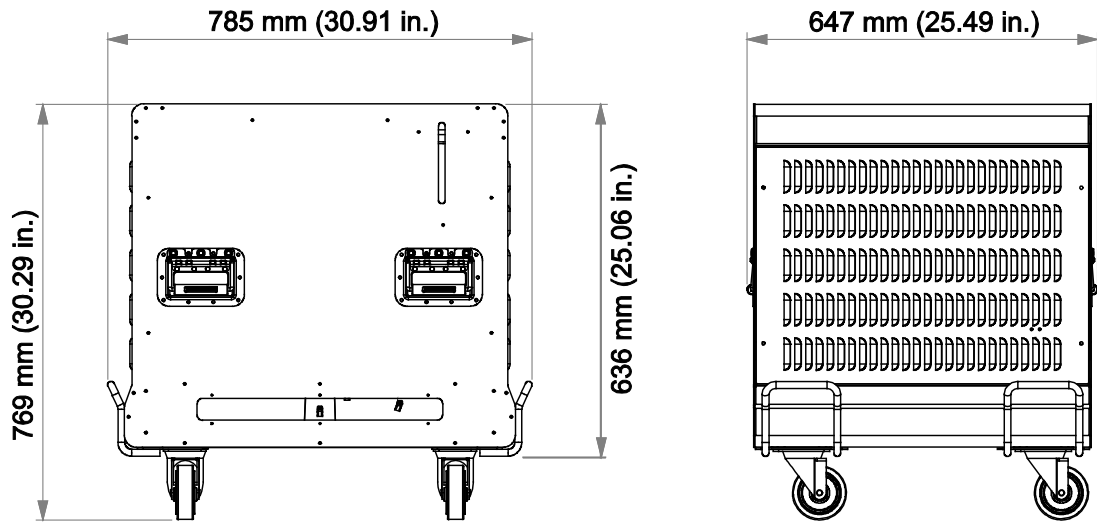

©2021 HARMAN PROFESSIONAL DENMARK ApS. All rights reserved. Features, specifications and appearance are subject to change without notice. HARMAN PROFESSIONAL DENMARK ApS and all affiliated companies disclaim liability for any injury, damage, direct or indirect loss, consequential or economic loss or any other loss occasioned by the use of, inability to use or reliance on the information contained in this document. Martin® and JEM™ are registered trademarks of HARMAN PROFESSIONAL DENMARK ApS registered in the United States and/or other countries.

HARMAN PROFESSIONAL DENMARK ApS, Olof Palmes Allé 44, 8200 Aarhus N, Denmark  
 HARMAN PROFESSIONAL SOLUTIONS U.S., 8500 Balboa Blvd., Northridge CA 91329, USA

[www.martin.com](http://www.martin.com)

JEM Glaciator Dynamic User manual, P/N 35010046 Rev. G

# Contents

Dimensions .....	2
Contents .....	3
Safety information.....	4
Product overview .....	7
Product description.....	7
Features at a glance .....	7
Product details .....	9
Installation and setting up .....	10
Location .....	10
AC power .....	10
Setting up.....	11
Final checks .....	11
Turning on the power.....	11
Control settings .....	12
Fast Access Keypad .....	12
Integrated Digital Remote Control .....	12
Setting Run modes .....	13
Setting Low-Fog output level .....	13
Setting the Timer.....	14
Using the Settings menu.....	14
Setting the DMX personality and start address .....	14
Display back light setting .....	14
Host/client link mode .....	15
Priming the machine .....	15
Using the DEFROST option .....	15
Resetting options to factory settings .....	16
DMX control .....	17
Overview .....	17
Connection.....	17
DMX functions.....	17
Setting options by RDM .....	18
Optional Accessories.....	20
Approved Low-Fog fluid types and usage .....	21
Maintenance .....	23
Fluid replacement .....	23
Cleaning using Martin® Pro-Clean & Storage Fluid.....	23
Waste Condensate collection .....	23
Exterior cleaning .....	24
Filter replacement .....	24
Fuse replacement .....	25
Troubleshooting .....	26
Status messages .....	27
Specifications .....	28

# Safety information



Read the safety precautions in this manual before installing, operating or servicing this product.

The following symbols are used to identify important safety information on the product and in this manual:



**Warning!**  
**Safety hazard. Risk of severe injury or death.**



**Warning!**  
**See user manual for important safety information.**



**Warning!**  
**Hazardous voltage. Risk of lethal or severe electric shock.**



**Warning!**  
**Hot surfaces.**



**Warning!**  
**Fire hazard.**



**Warning!** This product is not for household use. It presents risks of injury due to electric shock, burns, falls and respiratory problems!

Read this manual before operating the machine, follow the safety precautions listed below, and observe all warnings in this manual and printed on the machine. Use the machine only as described in this manual and in accordance with local laws and regulations.

If you have questions about how to operate the machine safely, or if you have followed the instructions in this manual and the machine is malfunctioning, please visit [www.martin.com/en-US/support](http://www.martin.com/en-US/support) to find your local Martin service center.



## Read the manual

- Install, operate and service Martin products only as directed in their user manuals, or you may create a safety hazard or cause damage that is not covered by product warranties.
- Follow the safety precautions listed below, observe all warnings in this manual, and printed on the product. Keep this user manual for future use.
- For the latest user documentation and other information for this and all Martin products, please visit the Martin website at <http://www.martin.com>
- Respect all locally applicable laws, codes and regulations when installing, operating or servicing the machine.



### Preventing electric shocks

- Always ground (earth) the machine electrically.
- Use only a source of AC power that complies with local building and electrical codes, and that has both overload and ground-fault protection.
- Before connecting the machine to power, check that the voltage indicated on the machine's serial label matches your local AC power voltage. If your AC power voltage does not match, do not use the machine. Contact Martin Service and Support for assistance.
- Before using the machine, check that all power distribution equipment and cables are in perfect condition and rated for the current requirements of all connected devices.
- If the machine or any cables connected to it are in any way damaged, defective, wet, or show signs of overheating, stop using the machine and contact Martin Service and Support for assistance. If the supply cord is damaged, it must be replaced by a special cord or assembly available from the manufacturer or its service agent.
- Disconnect the machine from AC power before servicing and when not in use.
- This machine is not waterproof and should not be exposed to wet outdoor conditions. Do not immerse in water or any other liquid. Do not expose to high-pressure water jets.
- Do not spill low- fog fluid over or inside the machine. If fluid is spilled, disconnect AC power and clean with a damp cloth. If fluid is spilled onto electronic parts, take the machine out of service and contact Martin Service and Support for advice.
- Do not remove the covers or attempt to repair a faulty machine. Refer any service not described in this manual to Martin Service and Support.
- Do not operate the machine if any parts are damaged, defective or missing.
- Moisture and electricity do not mix. Do not aim low-fog output at electrical connections or devices.

### Preventing burns and fire



- Low-fog output contains glycol, a flammable alcohol that burns with an almost invisible blue flame. Do not point low-fog output at sources of ignition such as open flames or pyrotechnic effects.
- Do not attempt to bypass thermostatic switches, fluid sensors or fuses.
- Replace fuses only with ones of the type and rating specified in this manual for the machine.
- Provide a minimum free space of 60 cm (24 in.) around the machine.
- Ensure free and unobstructed airflow to and around the machine. If in a confined space, ensure a supply of cool external air.
- Keep the machine at least 60 cm (24 in.) away from combustible and heat-sensitive materials.
- Do not operate the machine if the ambient temperature ( $T_a$ ) is below 5° C (41° F) or above 35° C (95° F).
- Do not operate the machine if the relative air humidity exceeds 80%.

### Preventing injuries



- This machine must be operated horizontally on the floor only. Do not use the bumper bars / lifting handles as rigging attachment points. The unit should not be used overhead.

- Ensure wheels are locked to prevent unintended movement of the machine.
- Check that all external covers are securely fastened.
- Do not operate the machine with missing or damaged covers or shields.
- In the event of an operating problem, stop using the machine immediately and disconnect it from power. Do not attempt to use a machine that is obviously damaged.
- Do not modify the machine in any way not described in this manual or install other than genuine Martin parts.
- Refer any service operation not described in this manual to a qualified technician.
- Low-fog output can cause condensation. Floors and surfaces may become slippery. Check these frequently and wipe dry as necessary to avoid any danger of slipping.
- Ensure at least 2 m (6.6 ft.) visibility in areas where low-fog is being produced.
- Low-fog fluid contains food-grade glycols in solution that may present health risks.

**IF SWALLOWED:** Do not induce vomiting. Drink 1-2 glasses of water and seek medical attention.

**AVOID CONTACT WITH SKIN AND EYES:** In case of accidental contact: **EYES:** Hold eyes open and flush with water for ten minutes, seek medical attention if irritation persists. **SKIN:** Remove contaminated clothing and rinse skin for 20 minutes, seek medical attention if irritation persists.

Consult the fluids' SDS for more detailed safety information at [www.martin.com/support/compliance](http://www.martin.com/support/compliance)

- This machine is not intended for use by persons (including children) with reduced physical sensory or mental capabilities, or lack of experience and knowledge, unless they have been given supervision or instruction concerning use of the machine by a person responsible for their safety. Children should be supervised to ensure that they do not play with the machine.

### Preventing breathing problems



- A machine can operate safely only with the low-fog fluid it is designed for. Use the machine only with fluids specified under “Low-fog fluid options” on page 20 or you may cause the release of toxic gases, presenting a severe health hazard. You will also probably damage the machine.
- Do not create dense low-fog in confined or poorly ventilated areas.
- Do not expose people with health problems (including allergic and/or respiratory conditions such as asthma) to fog output.
- Do not point low-fog output directly at a person’s face or at face height.

# Product overview

## Product description

The Glaciator Dynamic is a low-fog machine designed for a variety of applications such as performance based art, in touring and fixed installations. It can be easily integrated with most control systems currently used in the entertainment industry such as DMX with full RDM capability for remote setup and status monitoring. Additionally the integrated digital remote control can be operated on the machine or removed and used at a distance for quick and easy deployment.

The low-fog effect is attained by cooling the fog output from the heat exchanger until it is at a temperature lower than the ambient in which the machine is operating. Air is added to the fog, prior to cooling, from the integrated fan in the effect carburetor. This increases the volume of the fog effect and allows the low-fog to be propelled through the low-fog outlet. A fluid reservoir with 5 l capacity is provided for low-fog fluid. To allow reliable unattended operation, the fluid level is monitored electronically, and the device shut down if necessary. Waste condensation is pumped into a separate 0.5 l reservoir for convenient disposal on the top of the machine.

Optional accessories are available from Martin which provide enhanced solutions for low-fog creation such as the Ducting Kit, Fog Blade, External Fluid Reservoir Kit and Softcover for protection in transit. Detailed information about these value added accessories can be found in this manual under Accessories on page 30.

## Features at a glance

- Self-contained low-fog solution — no industrial gas or ice required
- Closed-loop refrigeration for colder, dense, longer-lasting low-fog
- All-new electronic inverter drive for improved effect quality and lower ambient noise
- Fill your stage with low-fog thanks to continuous 80 m<sup>3</sup> (2825 ft<sup>3</sup>) minute output
- Even smaller, service-friendly design: 785 x 648 x 769 mm (30.9 x 25.5 x 30.2 in)
- Ultra-quiet operation, 40.47 dBA in standby for low ambient noise
- World touring capabilities, universal power supply operates at 208-250 V, 50/60 Hz
- Onboard 3- and 5-pin DMX connectivity
- Intuitive user interface with Fast Access Keypad for fast, easy manipulation of low-fog output
- 180° Low-fog outlet engineered for limited aberrations in low-fog field
- Three premium fluid options create baseline for diverse effects
- One-touch fluid priming
- 5 l internal fluid reservoir, giving a minimum of 1 hour of consistent premium low fog output
- (Optional Accessory) JEM Glaciator Dynamic Ducting Kit for 3-way low-fog diversion

- (Optional Accessory) JEM Glaciator Dynamic Fog Blade for creative output points and waterfall-like low-fog effects
- (Optional Accessory) JEM External Fluid Kit for extended run-time
- (Optional Accessory) JEM Glaciator Dynamic Softcover made of reinforced ballistic nylon protects the machine in transit



*Use only genuine Martin JEM low -fog fluid as shown on page 20.  
Use of other fluid will void warran ty.*



**Product details**

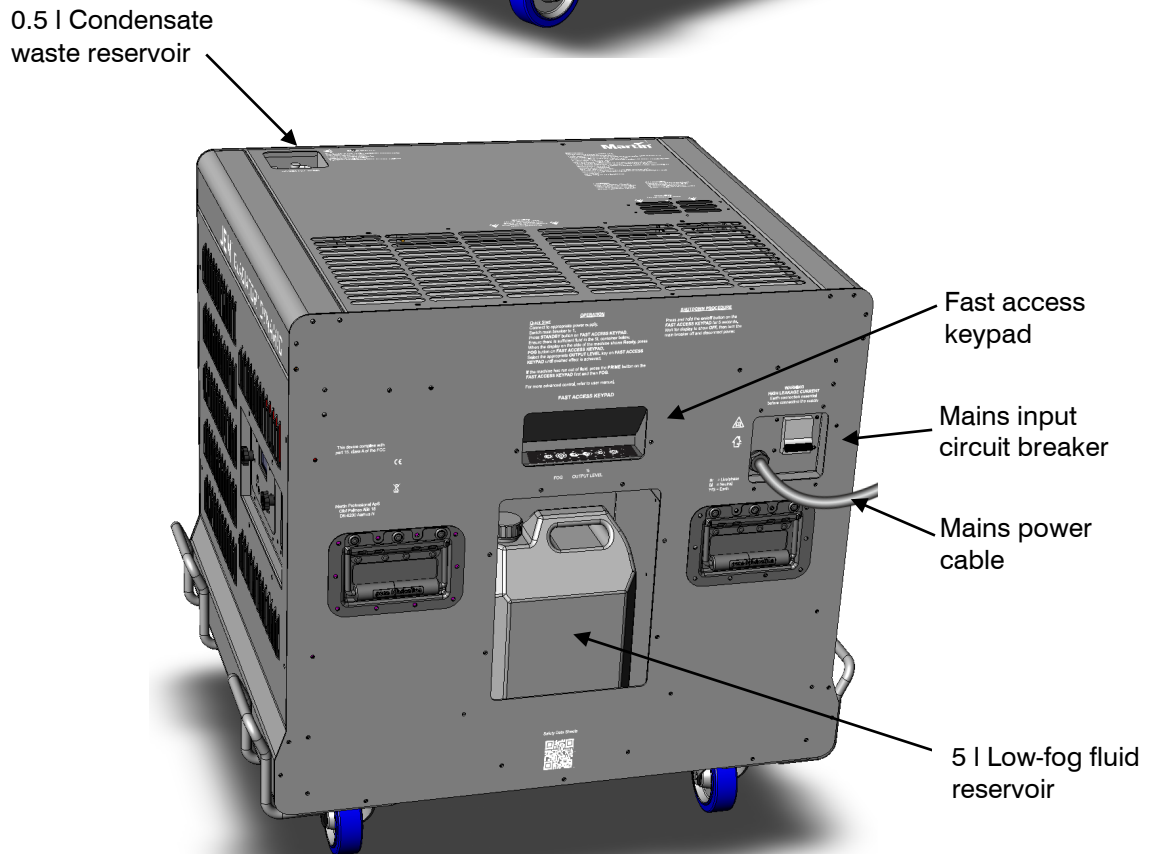

# Installation and setting up



**DANGER! DO NOT** operate the machine until you have read and observed all the precautions listed under “Safety information” on page 4.

## Location

The machine is designed to be operated in a dry location on the floor and should be kept in horizontal orientation. The maximum deviation from horizontal is 2°.

Ensure the machine has at least 60 cm (24 in.) clearance all-round and at least 60cm (24 inches) away from combustible and heat-sensitive materials. Ensure the same distance from the fog output if ducted.

This machine generates large amounts of waste heat (approximately 5KW at full output). Allow for this in the location, such that the ambient temperature is adequately controlled. The machine must not be allowed to recirculate it's own exhausted cooling air. Failure to observe these precautions will result in poor machine performance, and the possibility of machine damage in extreme cases.

## AC power

Before using the machine, ensure that a grounding-type (earthed) power plug that matches the local power receptacle is installed on the power cable provided.

This machine has a high earth leakage current and must only be operated from supplies with ground fault detection set at 30 mA. Only use an industrial receptacle/plug combination that reliably ensures earth connectivity before line connection. For example plugs and sockets conforming to any of the following:-  
IEC 60309-1  
IEC 60309-2  
UL 1682/1686  
CSA C22.2



For operating from supplies in the range 208 to 250 V, a minimum rated supply capacity of 25 A is required (32A preferred).

When installing the plug to the machine's mains cable, follow the plug manufacturer's instructions and connect pins as follows:  
Yellow and green wire to ground (earth), blue wire to neutral and brown wire to live.

The table below shows some common pin identification schemes.

wire	function	marking	screw colour
brown	live	“L”	yellow or brass
blue	neutral	“N”	silver
green/yellow	earth		green

Before connecting the machine to power, verify that the AC supply is adequately dimensioned for the current draw of the machine.

Check that the local AC voltage is appropriate, as indicated on the machine's serial number label. If your AC voltage is outside the appropriate range, do not use the machine. Contact Martin Service and Support for assistance.

## Setting up

Fill the low-fog fluid reservoir with a suitable Martin JEM low-fog fluid as shown on page 20. If DMX control is being used, connect the machine to the DMX line (see page 17).

## Final checks

Before applying power to the machine, verify the following:

- the machine is safely located or installed and meets the location requirements stated on page 10
- the operator is familiar with, and able to comply with, the requirements for safe operation listed on page 4.
- the fluid is one of the genuine Martin JEM low-fog fluids listed under "Fluid options" on page 20.
- the machine is electrically grounded (earthed)
- the AC power distribution circuits and lines are adequately rated for the current load

## Turning on the power

Ensure the mains circuit breaker on the rear of the unit is set to the 'ON' (I) position. The display will show **HEAT** and the heating and cooling systems will both start. If the display shows **OFF**, press the **FOG** button on the control panel or set the **RUN MODE** to **CONTINUOUS**. After about 6-8 minutes if no DMX is connected the display should show **FOG LEVEL** (along with the set output level) and the machine will begin producing fog. If DMX is connected the display will show **DMX** when the machine is ready.

- The machine will remember its state from when it was turned off last time, so it will only power up in OFF mode if you have previously disabled the heaters.



*To obtain optimal output, wait another few minutes after the READY indication is shown, as the machine continues to heat and cool to full operating temperature and low-fog output is reduced while the unit is heating up.*

*If the machine is restarted after a short off period (less than 5 minutes), the cooling system will need 5 minutes or more to reach a temperature at which low-fog can be produced again.*

# Control settings

## Fast Access Keypad

On the rear of the machine, fast access keys are provided to rapidly set the operating mode and parameters of the machine.

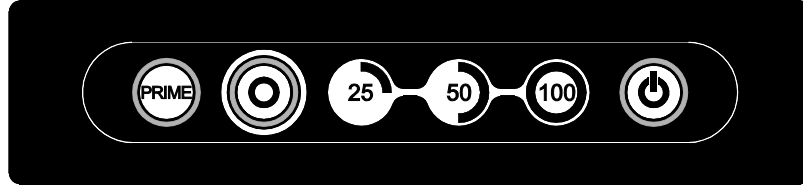

The Prime button activates Priming mode.

The large round button activates the low-fog output when the system is in a Ready state.

The 25-50-100 buttons enable low-fog output at 25%, 50% or 100% output.

The power button switches the unit between STANDBY (On) and OFF operational modes.

To enter OFF mode, hold the power button down for 5-seconds. Selecting OFF will disable the heaters and cooling system on the unit engaging the shutdown procedure of the machine for 160-seconds. During this period the waste condensate pump will move condensate fluid from the sump in the low-fog outlet into the waste condensate reservoir. Empty the waste condensate reservoir for travel and storage. Repeat if necessary until no more fluid is pumped.



*Empty the waste condensate reservoir prior to engaging the OFF shutdown procedure. It is possible for the shutdown procedure to produce condensate that could overflow the reservoir if it is already near capacity.*

The current machine status can always be viewed on the integrated digital remote control on the left-hand side of the machine.

## Integrated Digital Remote Control

The **integrated digital remote control** on the side of the machine allows you to configure all settings using option menus.



*The remote control may be removed from the unit and used at a distance by removing the two handwheel bolts either side of the display. The included remote cable is 5 m (16.4 ft.) and may be extended up to a maximum 25 m (82 ft.) using standard 3-pin XLR cable.*



### Setting Run mode

The RUN MODE menu sets the operational mode of the machine. Settings are OFF (shutdown, heaters off), STANDBY (heaters on), TIMER or CONTINUOUS output mode.

Use the Menu Previous / Next buttons to select the RUN MODE option. Use the Up/Down buttons to select OFF, STANDBY, TIMER, CONTINUOUS. Press the Enter button to activate the setting. The display shows SET.

Selecting OFF will disable the heaters and cooling system on the unit engaging the shutdown procedure of the machine for 160-seconds. During this period the waste condensate pump will move condensate fluid from the sump in the fog outlet into the waste condensate reservoir. Empty the waste condensate reservoir for travel and storage. Repeat if necessary until no more fluid is pumped.



*Empty the waste condensate reservoir prior to engaging the OFF shutdown procedure. It is possible for the shutdown procedure to produce condensate that could overflow the reservoir if it is already near capacity.*

### Setting Low -Fog output level

Use the Menu Previous / Next buttons to select the FOG LEVEL menu. Use the Up/Down buttons to select the level from 0% - 100%. Press the Enter button to store the fog output setting. The display shows SET.



*If you want to temporarily change the low-fog level, do not press Enter. The fog setting will go back to its stored value next time the machine is powered up. This applies to all options.*

## Setting the Timer

The timer function can be utilized to set the machine's output to automatically cycle between an 'On' time interval and an 'Off' time interval. This mode is useful for maintaining a low level of low-fog in smaller spaces.

First set the RUN TIME and OFF TIME values from the menu using the Menu Previous / Next buttons. The timer values are displayed in the range of 0-250 seconds. Select an interval for the 'On' time; Press Enter to store the value, SET is displayed. Follow the same procedure for the 'Off' timer.

Next select the Fog output value from the FOG LEVEL menu and press Enter, SET is displayed.

Finally select the TIMER option from the RUN MODE menu, press ENTER, SET is displayed. The timer will cycle continuously until the run menu option is changed.

## Using the Settings menu

Options such as the DMX start address, DMX personality setting, display brightness, stand-alone host/client linking mode, priming and factory reset are found in the SETTINGS menu.

Use the Menu Previous / Next buttons to select the SETTINGS option.

Press the Enter button to go to the SETTINGS menu.

To return to the main menu, use the Menu Previous / Next buttons to select EXIT and press Enter.

## Setting the DMX personality and start address

There are two DMX personalities available: 1-channel and 2-channel mode. See the DMX table on page 17 for more details. The default setting is 1-channel DMX mode. To change this to the 2-channel mode use the Menu Previous/Next buttons to select LINK MODE RECEIVE 2C, press Enter, SET is displayed.

To change the DMX start address, use the Menu Previous/Next buttons to select the DMX option from the SETTINGS menu. Use the Up/Down buttons to set the DMX base address from 001 to 512. If you hold down the button the address will count up or down more quickly. Press the Enter button to store the address setting, SET is displayed. (Note that the DMX start address range is limited from 001-511 in 2-channel mode.)

The machine will automatically respond to a DMX controller whenever it is connected. When using in a DMX system ensure the LINK MODE menu is set to RECEIVE (the default setting) to avoid causing DMX errors to other devices on the system.

Alternatively, the DMX personality and start address can be set via RDM.

## Display back light setting

You can set the brightness of the display backlight using the BACK LIGHT option.

Use the Previous / Next buttons to select the BACK LIGHT option from the SETTINGS menu.

Use the Up/Down buttons to change the option to LOW, NORM or HIGH. Press the Enter button to store the setting, SET is displayed.

Note that later machines (firmware 1v2 and above), have a timer function on the LOW setting. This will blackout the display after 20 seconds of inactivity, and additionally, turn off the condensate reservoir illumination (if the required hardware is present).

### Host / client link mode

It is possible to control several machines from one digital remote control. The machine with the remote plugged into it is set as the Host. The other machines are set as Clients. The machines are interconnected with DMX cabling.

Use the Menu Previous / Next buttons to select the LINK MODE option from the SETTINGS menu.

Use the Up/Down buttons to select RECEIVE 1C (client unit) or SEND (host unit).

Press the Enter button to store the link setting, SET is displayed.

The machine should be set to SEND only if it is running as the host. If running as a client, stand-alone or DMX controlled it should be set to RECEIVE 1C. If a machine set to SEND is connected to an active DMX system, the DMX will be corrupted causing flickering of lights and other strange symptoms.

### Priming the machine

Upon first use of the machine or if the machine runs out of fluid it will automatically shut down and display FLUID OUT on the display to prevent damage to the pump. To suck the new fluid back into the machine and reset the FLUID OUT error, replace/refill the low-fog fluid reservoir and use the prime function – just press the Prime button on the fast access keypad on the rear of the machine.

Alternatively, you can start Prime from the digital remote panel:

Use the Menu Previous / Next buttons to select the PRIME option from the SETTINGS menu.

Use the Up/Down buttons to change the option to YES.

Press the Enter button to start the priming function.

The pump will operate at full power for a short time to purge air from the pipes inside the unit.

To exit this menu if you decide not to activate the Prime function, select NO and press ENTER.

If air has entered the system, it is sometimes necessary to run the prime function again.

### Using the DEFROST option

Use this option to run a repeat shutdown cycle including a defrost cycle. Select the menu and chose Yes, then press enter to start the cycle.

This function will commonly be required when the machine has been idling for some time and has accumulated ice and frost within the evaporator unit. Since the cycle includes operation of the condensate pump, it should not be run without first emptying the condensate reservoir. Perform a standard shutdown using the ON/OFF button first, then use additional defrost cycles as required. Running this option from the normal run mode (RUN = STANDBY), will perform a standard shutdown cycle.

## Resetting options to factory settings

The factory settings configure a standard mode of operation for the machine.

Use the Menu Previous / Next buttons to select the RESET option from the SETTINGS menu.

Use the Up/Down buttons to change the option to YES.

Press the Enter button to reset all options.

To exit this menu if you decide not to reset the options, select NO and press Enter.

The factory settings are:

option	setting
FOG LEVEL	50%
TIMER ON	10 seconds
TIMER OFF	20 seconds
RUN MODE	STANDBY
DMX	001
BACK LIGHT	NORM
LINK MODE	RECEIVE 1C
PRIME	NO
DEFROST	NO



# DMX control

## Overview

DMX is a digital control protocol widely used in entertainment and architectural lighting. Any DMX controller meeting the DMX-512A standard may be used to control the machine. A controller that is RDM compliant will be able to program and monitor some settings of the machine remotely.



*When a DMX signal is present, the machine's stand-alone functions do not work. To control the machine locally the DMX controller must be powered off or disconnected.*

*If the DMX signal is removed (controller turned off or unplugged) , the machine will revert to its previously stored RUN MODE settings.*

*If the machine was set to OFF , it will revert to this state.*

*If the machine was set to STANDBY, it will revert to this state.*

*If the machine was set to TIMER , it will revert to this state.*

*If the machine was set to CONTINUOUS , it will revert to this state.*

## Connection

The machine provides 3-pin and 5-pin XLR connectors on the side of the machine for DMX connection. For best results, use cable designed for high-speed digital data transmission.

Do not utilize the DMX output connections as a splitter. Do not connect DMX cables to both the 3- and 5-pin DMX outputs at the same time as this will form a branch in the DMX wiring which may cause data errors.

## DMX functions

The DMX start address must match the DMX start address assigned to the Glaciator on your controller. To set the address, see "Setting the DMX personality and start address" on page 14. The machine has two DMX personalities, requiring one or two DMX channels. The mode is set using the two RECEIVE options in the LINK menu.

When the machine is at running temperature and is under DMX control it displays DMX (+ the current DMX base address).

The DMX control values are shown in the table below.

### 1 Channel Mode (RECEIVE 1C)

Channel	DMX value range	Function	Macro description	Default value
1 Low-fog output level	0-12	Idle range	None	0
	13- 240	Output 0-100%		
	241 -255	Output 100%		

## 2 Channel Mode (RECEIVE 2C)

Channel	DMX value range	Function	Macro description	Default value
1 Low-fog output level	0-12	Idle range	None	0
	13- 240	Output 0-100%		
	241 -255	Output 100%		
2 Control functions	0-50	No function		
	51-100	Prime	Primes the machine	
	101-150	No function		
	151-200	OFF- Shutdown	Switches off heating and cooling, engages the shutdown procedure	
	201-255	Standby - Heaters on	Switches on the heating and cooling systems, machine in Standby	



*To activate a control function, the DMX value must be held in the correct range for 5 seconds.*

## Setting options by RDM

You can remotely configure the fixture over DMX using RDM. Martin offers a range of suitable RDM-compatible controllers.

A full list of the RDM functions that the machine supports is given at the end of this section. These functions are generally referred to using the more specific term 'PIDs' or 'Parameter IDs'.

### Scanning for RDM devices on the data link

Before you can communicate with fixtures using RDM, you must send a scan command (also called a device discovery command) to all the devices on the data link so that the RDM controller can identify them. It does this by retrieving each device's factory-set unique identifier (UID). This process can take some time depending on the number of devices on the link.

To identify the fixtures on the link:

1. Check that the fixtures are correctly connected to the RDM controller on the data link and that power is applied to all fixtures.
2. Give the controller time to identify the devices on the link and prepare for communication with the devices.

### Getting status and setting options by RDM

The status and options listed in the table below can be read and set by RDM.

You can set an option on one fixture by sending a unicast RDM command to that one fixture only, or you can set the same option on all the fixtures on the data link by sending a broadcast RDM command to all the devices on the link. For status reading, you can only use unicast RDM to read information from an individual fixture.

### **RDM functions**

As a minimum, the fixture supports the following RDM functions:

#### ***Device discovery***

DISC_UNIQUE_BRANCH
DISC_MUTE
DISC_UN_MUTE

#### ***Device management***

	<b>GET</b>	<b>SET</b>
DEVICE_INFO	✓	
IDENTIFY_DEVICE	✓	✓
DMX_START_ADDRESS	✓	✓
SOFTWARE_VERSION_LABEL	✓	
SUPPORTED_PARAMETERS	✓	
PARAMETER_DESCRIPTION	✓	
COMMS_STATUS	✓	
QUEUED_MESSAGE	✓	
STATUS_MESSAGES	✓	
DEVICE_MODEL_DESCRIPTION	✓	
MANUFACTURER_LABEL	✓	
DEVICE_LABEL	✓	✓
FACTORY_DEFAULTS		✓
DMX_PERSONALITY	✓	✓
DMX_PERSONALITY_DESCRIPTION	✓	
DEVICE_HOURS	✓	
BOOT_SOFTWARE_VERSION_ID	✓	
BOOT_SOFTWARE_VERSION_LABEL	✓	
SLOT_DESCRIPTION	✓	✓
RESET_DEVICE		✓

The standard status update mechanism is the QUEUED MESSAGE function. This allows the user to recover status messages such as FLUID\_OUT. The following status messages are available:-

STS_OVERTEMP	Error code
STS_CAL_FAIL	Error code
STS_LOW_FLUID	Advisory
STS_NOT_READY	Advisory
STS_READY	Advisory

# Optional Accessories

## **JEM Glaciator Dynamic, Ducting Kit: P/N 92625020**

The Glaciator Ducting Kit is a 3-way low-fog diverter kit that handily affixes to the low-fog outlet of the Glaciator. The included ducting adaptor is made of steel and finished in a matte black powder coating. The Ducting Kit includes three 150 mm (6 in.) x 5 m (16.4 ft.) flexible ducting hoses and allows the Glaciator to be located off-stage and for low-fog to be transported to the performance area and evenly distributed. If desired, individual outlet ports on the adaptor can be sealed off and low-fog can be ducted to any or all three of the ports, up to a maximum distance of 10 m (32.8 ft.). The optional Fog Blade system (available separately) can be employed for even more control and dispersion of the low-fog effect.

## **JEM Glaciator Dynamic, Fog Blade: P/N 92625025**

The Fog Blade is an extension of the Glaciator Ducting Kit, allowing covert precision low-fog to be channelled via a single 6" ducting hose discreetly under stage sets and drapery, hung overhead, or affixed under a floor. The Fog Blade is made of lightweight aluminium and powder coated in a matte black finish. The shallow, angled, industrial design and diverter panels ensure smooth, uniform low-fog output. The Fog Blade has rubberized, non-slip feet to protect delicate surfaces and a convenient carrying handle for ease of quick placement during scene changes. Additional hanging points are integrated to allow for overhead use of the Fog Blade to create dramatic waterfall type effects from up to 10 m. Up to three Fog Blades can be used with one JEM Glaciator Dynamic equipped with a Glaciator Ducting Kit.

## **JEM External Fluid Reservoir Kit, 25l: P/N 92620035**

The External Fluid Reservoir Kit, when employed with the JEM Glaciator Dynamic, can be used for two applications. The first as an extended low-fog fluid source, expanding fluid capacity from 5 l to 25 l externally and providing extended run-time of the machine with less frequent fill-ups or when the machine is not readily accessible. The second as an extended reservoir for waste water condensate from 0.5 l to 25 l. The Fluid Reservoir Kit is a sealed 25 l reservoir with 1.5 m (4.9 ft.) of 8 mm flexible silicone tubing that easily connects to the existing barbed standpipes on the Glaciator Dynamic and other JEM products and features quick-connect fittings on the cap for fast and easy filling or draining.

## **JEM Glaciator Dynamic, Softcover: P/N 92625030**

The Glaciator Softcover is a custom protective cover for the JEM Glaciator Dynamic constructed of reinforced heavy duty black PVC, 12 mm internal padding and finished internally with brushed nylon. The Softcover is screen printed with the product name and features a clear PAL placard pocket. The softcover features a convenient hook and loop fastener system for easy deployment and will protect the Glaciator from the rigors of transit in the touring industry. A bump-out compartment allows the optional ducting adapter to remain affixed to the machine and remain protected during transit.

## Approved Low-Fog fluid types and usage

The Glaciator Dynamic may only be used with the genuine Martin JEM low-fog fluids listed below. Martin supplies premium quality low-fog fluids that are based on ultra-pure deionized water. No other fluid is suitable for use and such use will void the warranty.

Use fluid directly from container, do not dilute. Remove cap and safety seal; if inner safety seal has been tampered with, return product to point of purchase. Disconnect machine from power source before filling reservoir. When possible, remove reservoir from machine and carefully fill reservoir to desired level, taking care not to overfill or spill. Wipe up any spilled fluid with a damp cloth. Replace cap on container and store upright in a secure location.

### **JEM Low -Fog Fluid , Quick Dissipating**

JEM Low-Fog Fluid, Quick Dissipating is a water-based fog formula specially designed for use in the JEM Glaciator. JEM Low-Fog Fluid, Quick Dissipating produces a dense pure-white ground-hugging effect, which will disperse and evaporate before any visible rising and heat exchanging. This light-density fluid formula has a faster dispersion rate and is less dense than the benchmark JEM Low-Fog Fluid. JEM Low-Fog Fluid, Quick Dissipating combines a low density and reduced hang time for the precision of performance based art in clubs, theatres and touring applications in addition to fixed installations and special effects design.

### **JEM Low -Fog Fluid**

JEM Low-Fog Fluid is the industry standard water-based low-fog formula specially designed for use in the JEM Glaciator. This benchmark fluid is the automatic choice of most users and is the most specified low-fog fluid on the market. JEM Low-Fog Fluid produces a dense, pure-white ground-hugging effect which will disperse and evaporate before any visible rising and heat exchanging; which is ideal for dramatic scenes involving moving stage activity such as dance. JEM Low-Fog Fluid combines a typical density and hang time for the precision of performance based art in clubs, theatres and touring applications in addition to fixed installations and special effects design.

### **JEM Low -Fog Fluid , High Density**

JEMTM Low-Fog Fluid, High Density is a water-based low-fog formula specially designed for use in the JEM Glaciator. JEM Low-Fog Fluid, High Density produces a dense pure-white ground-hugging effect which will disperse and evaporate before any visible rising and heat exchanging. A longer lasting, higher density low-fog is sometimes required for a more controlled environment and with its longer hang time, JEM Low-Fog Fluid High Density is well suited for 'waterfall' and 'curtain' type effects or for obscuring scenery and performers in low-lying clouds. JEM Low-Fog Fluid High Density combines a high density and long hang time effect for the precision of performance based art in clubs, theatres and touring applications in addition to fixed installations and special effects designs.

### **Martin Pro Clean & Storage Fluid**

Martin Pro-Clean & Storage Fluid is specially designed for optimizing performance while providing longevity of any effect machine. Martin Pro-Clean & Storage fluid is the ultimate cleaning solution for Martin atmospheric effect heat exchangers. This advanced preventative maintenance fluid has been utilized by Martin service technicians for years of both cleaning and storing effect machines. Utilizing Martin Pro-Clean & Storage Fluid on a regular basis reduces

clogging and further extends the life of your Martin atmospheric effect machines. By using the highest grade chemicals available while remaining eco-friendly, Martin fluids are both effective and safe.

Instructions for using Martin Pro-Clean and Storage Fluid can be found on the following page.

### **Approved Martin Discontinued Fluids**

Heavy Fog Fluid (A1)

Heavy Fog Fluid (B2)

Heavy Fog Fluid (C3)

Pro Clean Supreme



**DANGER!** The Glaciator Dynamic can run safely only on the specific low-fog fluids aforementioned. Use **ONLY** genuine Martin JEM Low-fog fluids designated in this manual.

**NEVER** use any other type of fluid. Toxic gas may be produced and damage to the machine that will invalidate the product warranty will result. Do not dilute low-fog fluid with water or any other liquid. Discard fluid if it becomes contaminated.

# Maintenance



Before servicing the machine, read and observe all the precautions listed in “Safety information” on page 4. Any service not described in this section must be carried out by a qualified Martin service technician.

To find your local Martin Service Center visit [www.martin.com/en-US/support](http://www.martin.com/en-US/support)

## Fluid replacement

When the fluid level gets low, replace or refill the fluid reservoir in the rear of the machine, ensuring that the fluid tube reaches to the bottom of the bottle.

Whenever you refill the fluid you should also empty the condensate collection bottle (see section below).

If machine had run out of fluid, you may need to activate the Prime function using the button on the rear of the machine to eliminate airlocks from the internal pipework. It may be necessary to activate the Prime function twice to fully fill the fluid lines, or more times if a remote fluid supply is used. The fluid pressure sensor will automatically stop the priming when the machine is operational.

## Cleaning using Martin® Pro-Clean & Storage Fluid

**Cleaning and Preventative Maintenance Procedure:** Use Martin Pro Clean and Storage Fluid after every 200 hours of operation or monthly depending on usage and duty cycle.

In a well ventilated area temporarily connect Martin Pro Clean and Storage Fluid to the effect machine being serviced or fill the machine’s provided fluid reservoir. Allow the machine to fully heat. When machine is ready activate the machine to run continuously for 30-45 minutes; using a timer function if available. When completed, replace cleaning fluid with appropriate low-fog fluid.

**Storage Procedure:** Perform the above cleaning and preventative maintenance procedure. After procedure is completed simply run the machine until all fluid has been visibly purged from the fluid inlet tubing to prevent leaks and seepage.

## Waste Condensate collection

As the fog is cooled, condensation will form inside the machine. This condensate is pumped into a 0.5 l reservoir at the front left corner of the machine during normal operation every 2-minutes and when the machine is turned OFF.

You should regularly check the level in this reservoir using the illuminated sight gauge on the front of the machine, and empty the reservoir if it becomes full. Normally if you empty the reservoir every time you refill the low-fog fluid, this will be sufficient.



*Empty the waste condensate reservoir prior to engaging the OFF shutdown procedure. It is possible for the shutdown procedure to produce condensate that could overflow the reservoir if it is already near capacity.*

The condensate collected in the reservoir cannot be re-used. Dispose of it responsibly.

Whenever you replace or fill the low-fog fluid reservoir, always empty the condensate reservoir at the same time. The condensate reservoir should have enough capacity for the condensate generated from a 5 l container of fluid used at 50% output level. If you are installing the machine or running for long periods, consider using the optional “External Fluid Kit” which increases the reservoir capacity to 25 l.

The condensate pumping time of 2 minutes can be adjusted by a Martin Service Center, if your local conditions require it.

## Exterior cleaning

Excessive dust, effects fluid, and dirt build-up will degrade performance and cause overheating and damage to the machine that is not covered by the product warranty. To maintain adequate cooling, dust must be cleaned from the outer casing and air vents of the machine periodically.



Isolate the machine from power and allow to cool completely before cleaning. Internal parts remain hot for a period after use.

- Remove dust from the air vents with a soft brush, cotton swab, vacuum, or compressed air.
- Clean effects fluid residues from the low-fog output of the machine using a damp cloth.
- Clean the outer casing with a damp cloth only.

## Filter replacement

The machine uses a washable synthetic fiber filter in the intake for the condenser fans. The filter is located in the top plate of the machine and can be removed for cleaning or replacement by removing the top cover, held in place with 6x Pozidriv #2 screws (M5).

To clean the filter, simply wash with warm water and a mild detergent, and allow to air dry. Filter replacement part: 56210056 - Condenser filter, Dynamic.





DANGER! Disconnect the power supply before removing any covers. Live parts will be exposed when removing the top cover!

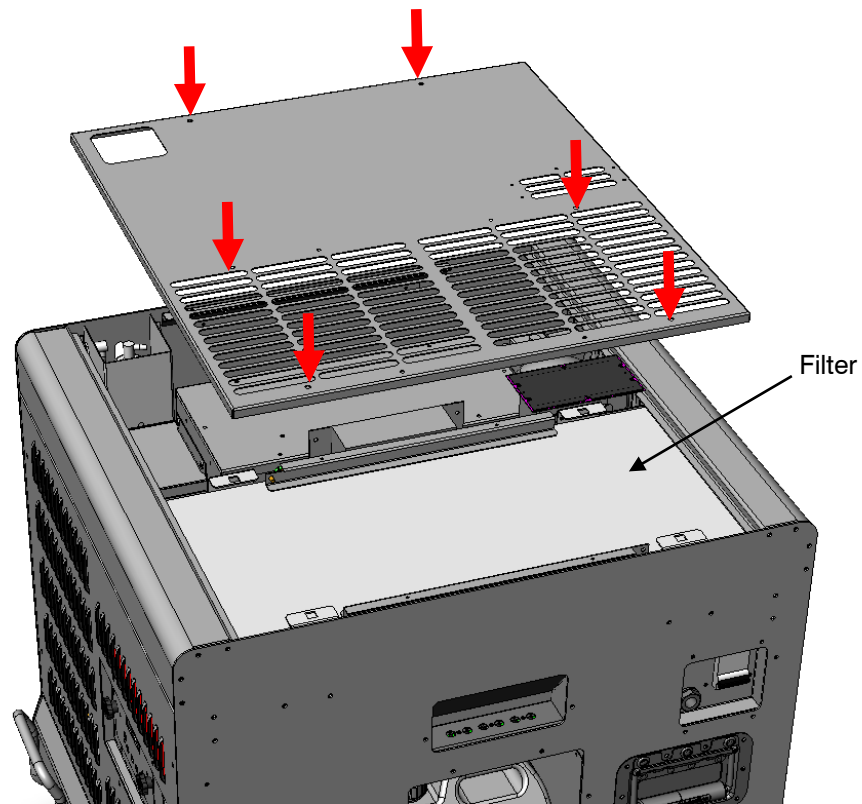

- Under normal conditions (clean and dry environment) inspect and clean/replace the filter every 250 hours of operation
- Under severe conditions (dirty and/or damp environment) inspect and clean/replace the filter every 150 hours of operation

### Fuse replacement

The machine uses a miniature Thermo-magnetic circuit breaker (MCB) on the rear panel as its primary means of over current protection. This is rated at 25 A, 240V max., 50/60Hz to allow for the inrush and starting currents generated by the cooling system compressor. Any severe over current event will be disconnected by the MCB.

If the machine repeatedly trips, there is an internal fault, and the machine must be examined by a suitably qualified Martin service technician.

All internal circuits are protected individually by fuses in various locations within the wiring and control electronics. If any of these fuses blow, the machine should be investigated by a suitably qualified Martin service technician.



DANGER! Disconnect the power supply before removing any covers or changing fuses. Live parts inside!

# Troubleshooting

Problem	Probable cause(s)	Suggested remedy
Machine will not produce low-fog when control panel set to <b>CONTINUOUS</b> or fog button pressed	Machine not at operating temperature	Wait until HEAT message no longer shown
	FOG option set to 0	Increase setting
	Machine in timer mode and <b>TIMER ON</b> set to 0	Increase setting
	DMX signal present	Disconnect or turn off DMX controller
Machine can be fired from control panel, but not by DMX controller	DMX address setting incorrect	Change DMX address (page 14)
	Poor connection in DMX line	Check DMX cables and connections
	LINK menu is set to <b>SEND</b>	Set LINK menu to <b>RECEIVE</b>
Low-fog output is weak	Machine requires priming	Use <b>PRIME</b> option to prime the machine (page 15)
Wet, greasy, non-uniform low-fog output, or very loud noise when firing machine	Incompatible low-fog fluid	Use approved fluid!
Machine appears dead	Main MCB tripped	Reset MCB on rear panel
	No power at AC cable inlet	Check power cable and supply system circuit breakers
Machine causes DMX errors to occur on other units when connected to a DMX system	LINK menu is set to <b>SEND</b>	Set LINK menu to <b>RECEIVE</b>
Loss of control from remote	Communication issue between remote and machine	Check cable connection between remote and machine. Ensure cable is no longer than 25 m (82 ft.)

## Status messages

message	reason
OFF	The heaters are Off, the unit is shut down. If the countdown clock is shown this indicates the shutdown procedure is in progress.
HEAT	The unit is heating up to operating temperature.
READY	The heater is at operating temperature, but Fog is not turned on (RUN set to STANDBY).
DMX	The heater is at operating temperature and the unit is under DMX control.
FLUID OUT	Machine out of fluid. Refill the low-fog fluid reservoir and operate the prime function in the SETTINGS menu
CALIBRATION ERROR	The machine has detected an error with its calibration settings and will not operate. Contact Martin Service and Support.
SYSTEM ERROR	The machine has detected an error in the temperature sensor and will not operate. Contact Martin Service and Support.

# Specifications

## Physical

Length .....	785 mm (30.91 in.)
Width .....	648 mm (25.52 in.)
Height.....	769 mm (30.29 in.)
Height without castors .....	636 mm (25.06 in.)
Weight, dry .....	124 kg (274 lb.)
Weight, filled.....	129 kg (285 lb.)

## Performance

Coverage volume .....	80 m <sup>3</sup> (2825 ft <sup>3</sup> ) / minute
Fluid consumption, continuous maximum output .....	70 ml / minute
Effect output .....	continuous
Ready time (minimum).....	5-minutes
Ready time (optimal output) .....	7-minutes

## Control and programming

Control options .....	Integrated digital remote control, fast access keypad, .....DMX/RDM, host/client
Control parameters .....	Continuous or timer-controlled output
Low-fog/Fan .....	Proportionally controlled output, 0-100%
Setting and addressing .....	Control panel with backlit LCD display and ..... 6 button user interface, or via RDM
DMX channels .....	1, 2
DMX compliance .....	ANSI E1.11 - USITT DMX512-A
RDM compliance.....	ANSI/ESTA E.120 RDM

## Construction

Housing.....	Steel
Color.....	Black
Portability .....	Removable castors
Protection rating.....	IP20
Heat exchanger.....	2500W, thermally protected
Fluid pump, low-fog fluid .....	Oscillating piston, high pressure
Fluid pump, waste condensate.....	Peristaltic pump, low pressure
Fluid management, low-fog fluid .....	Fluid out sensing, sealed for transportation
Fluid management, waste condensate.....	Visual sight gauge, .....LED illuminated reservoir
Fluid reservoir, low-fog fluid.....	5 l drop-in reservoir ..... with quick connect fitting or external source
Fluid reservoir, waste condensate .....	0.5 l drop in reservoir ..... with quick connect fitting or external source
Refrigeration .....	Closed loop system, variable speed condenser fans, ..... electronic expansion valve
Refrigeration control.....	PWM electronic control
Refrigerant.....	R407F, 0.95 kg (2.09 lb.)
Remote control.....	Integrated digital remote with 5 m (16.4 ft.) cable, 3-pin XLR
Remote control cable length (max.) .....	25 m (82 ft.)
Optional Ducting Kit .....	Black, steel, triple ducting adaptor with ..... 3x 5 m (16.4 ft.) 150 mm (6 in.) OD flexible ducting hoses ..... and includes 3x stainless steel duct clamps, worm drive, hex screw
Optional Fog Blade .....	Black, steel, 150 mm (6 in.) outlet,

..... includes 1x stainless steel duct clamp, worm drive, hex screw  
 Optional External Fluid Kit..... 25 l sealed fluid reservoir,  
 ..... 1.5 m (4.9 ft.) 8 mm OD, 6 mm ID, silicone tubing, pipetta fitting  
 Optional Softcover ..... Black, heavy duty PVC external,  
 ..... brushed nylon padding interior, hook and loop fastener system,  
 ..... 5 in. x 8 in. transparent PAL transit pocket

**Installation**

Orientation..... Horizontal only  
 Location..... Dry location only  
 Clearance around machine..... 60 cm (24 in.)  
 Ducting..... Optional, max. length 10 m (32.8 ft.)

**Connections**

AC Power ..... Hardwired flexible mains cable, 3 x 4.0 mm<sup>2</sup> (6 AWG),  
 ..... 3.3 m (10.8 ft.)  
 DMX/RDM in/out ..... 3- and 5-pin locking XLR  
 Remote control..... 3-pin locking XLR  
 Firmware ..... AVR socket  
 Fluid inlet, low-fog fluid ..... Brass barbed hose tail, 6 mm  
 Fluid outlet, waste ..... Brass barbed hose tail, 6 mm

**Electrical**

AC power ..... 208 - 250 V single phase, 50/60 Hz  
 Typical power consumption, standby..... 10 W  
 Typical power consumption, maximum..... 3500 W  
 Power supply unit ..... Auto-ranging electronic switch-mode  
 Integrated resettable circuit breaker ..... 25 A, 240 V max., 50/60 Hz  
 Half-cycle RMS inrush current at 230 V, 50 Hz..... 20 A

**Typical Power and Current**

208 V, 60 Hz..... 3350 W, 17.8 A, PF 0.96\*  
 220 V, 50 Hz..... 3350 W, 16.9 A, PF 0.96\*  
 230 V, 50 Hz..... 3350 W, 15.6 A, PF 0.96\*  
 240 V, 50 Hz..... 3350 W, 15.2 A, PF 0.96\*

*\*Figures are typical, not maximum. Measurements made at nominal voltage, allow for a deviation of +/- 10%.  
 PF = Power Factor*

**Thermal**

Cooling..... Forced air, low noise  
 Maximum ambient temperature (Ta max.)..... 35° C (95° F)  
 Minimum ambient temperature (Ta min.) ..... 5° C (41° F)  
 Exterior surface temperature, steady state ..... 30° C (86° F)  
 Total heat dissipation, idle (calculated, +/- 10%) ..... 2241 BTU/hr.  
 Total heat dissipation, full load (calculated, +/- 10%) ..... 11430 BTU/hr.

**Acoustic**

Noise level average, maximum low-fog output..... 62.76 dBA  
 Noise level average, standby..... 40.47 dBA

## Approvals

EU Safety .....EN 60335-1  
EU EMC.....EN 61000-6-3, EN 62233  
EU Immunity.....EN 61000-6-1  
Australia/NZ (pending).....RCM

United Kingdom ..... UKCA



## Included items:

Fluid reservoir 5 l.....P/N 34300506  
Fluid reservoir 0.5 l.....P/N 34300515  
User manual ..... P/N 35010046 (print only)

## Accessories

JEM Glaciator Dynamic, Ducting Kit.....P/N 92625020  
JEM Glaciator Dynamic, Fog Blade.....P/N 92625025  
JEM Glaciator Dynamic, Softcover .....P/N 92625030  
JEM External Fluid Reservoir Kit, 25 l .....P/N 92620035

## Approved fluids

JEM™ Low-Fog Fluid, Quick Dissipating

JEM™ Low-Fog Fluid

JEM™ Low-Fog Fluid, High Density

Martin® Pro-Clean and Storage Fluid

*Various sizes available - contact your dealer or see 'Fluids' product pages for details*

## Service tools

Epsilon 5 AVR Programmer .....P/N 50502004  
Temperature Calibration Box.....P/N 92620005

## Ordering information

JEM™ Glaciator™ Dynamic: .....P/N 92210525

*Specifications subject to change without notice. For the latest product specifications, see [www.martin.com](http://www.martin.com)*



**Disposing of this product**

Martin products are supplied in compliance with Directive 2012/19/EC of the European Parliament and of the Council of the European Union on WEEE (Waste Electrical and Electronic Equipment), where applicable. Help preserve the environment! Ensure that this product is recycled at the end of its life. Your supplier can give details of local arrangements for the disposal of Martin products

