



**PROTEUS  
RAYZOR 760 /  
RAYZOR 760 WMG  
User Manual**

©2023 ELATION PROFESSIONAL all rights reserved. Information, specifications, diagrams, images, and instructions herein are subject to change without notice. ELATION PROFESSIONAL logo and identifying product names and numbers herein are trademarks of ELATION PROFESSIONAL. Copyright protection claimed includes all forms and matters of copyrightable materials and information now allowed by statutory or judicial law or hereinafter granted. Product names used in this document may be trademarks or registered trademarks of their respective companies and are hereby acknowledged. All non-ELATION brands and product names are trademarks or registered trademarks of their respective companies.

**ELATION PROFESSIONAL** and all affiliated companies hereby disclaim any and all liabilities for property, equipment, building, and electrical damages, injuries to any persons, and direct or indirect economic loss associated with the use or reliance of any information contained within this document, and/or as a result of the improper, unsafe, insufficient and negligent assembly, installation, rigging, and operation of this product.

**Elation Professional USA** | 6122 S. Eastern Ave. | Los Angeles, CA. 90040  
323-582-3322 | 323-832-9142 fax | [www.elationlighting.com](http://www.elationlighting.com) | [info@elationlighting.com](mailto:info@elationlighting.com)

**Elation Professional B.V.** | Junostraat 2 | 6468 EW Kerkrade, The Netherlands  
+31 45 546 85 66 | +31 45 546 85 96 fax | [www.elationlighting.eu](http://www.elationlighting.eu) | [info@elationlighting.eu](mailto:info@elationlighting.eu)

**Elation Professional Mexico**  
AV Santa Ana 30 | Parque Industrial Lerma, Lerma, Mexico 52000  
+52 (728) 282-7070



## DOCUMENT VERSION

Due to additional product features and/or enhancements, an updated version of this document may be available online. Please check [www.elationlighting.com](http://www.elationlighting.com) for the latest revision/update of this manual before beginning installation and/or programming.

Date	Document Version	Software Version	DMX Channels	Notes
05/28/2019	1.0	1.2.1	25 / 52 / 80	Initial release
09/30/2019	1.1	N/C	No Change	Included RJ4 data cable note.
10/15/2019	2.0	1.2.2	No Change	Updated System sub menus, DMX Control Channel, RGBW/ SparkLED FX Tables
03/05/2020	2.5	N/C	No Change	Added torque screw setting page
05/12/2020	3.0	N/C	No Change	Added Elation Proteus Rayzor 760 WMG
08/10/2020	3.5	N/C	No Change	Updated thermal
10/14/2020	4.0	N/C	No Change	Updated specifications
02/04/2021	4.5	1.2.4	No Change	Updated primary/secondary modes
03/15/2021	5.0	N/C	No Change	Hibernation/sun protection warning and information
05/20/2021	5.5	N/C	No Change	Updated Maintenance Guidelines
08/15/2022	6.0	N/C	No Change	Updated Introduction, System Menu, DMX Traits, and Torque settings for screws; added RDM; updated formatting
08/23/2022	6.5	1.3	No Change	Updated System Menu
12/20/2022	7.0	N/C	No Change	Added Limited Warranty; updated Specifications, Torque Settings for Screws
03/17/2023	7.5	1.3.3	No Change	Updated System Menu

# TABLE OF CONTENTS

<b>Introduction</b>	<b>4</b>
<b>Limited Warranty (USA Only)</b>	<b>5</b>
<b>Warranty Returns (USA Only)</b>	<b>6</b>
<b>Safety Precautions</b>	<b>7</b>
<b>Maintenance Guidelines</b>	<b>9</b>
<b>Overview</b>	<b>10</b>
<b>Installation Guidelines</b>	<b>11</b>
<b>Torque Settings for Screws</b>	<b>16</b>
<b>Remote Device Management (RDM)</b>	<b>18</b>
<b>System Menu</b>	<b>19</b>
<b>Record Controller</b>	<b>28</b>
<b>Lighting Console Patching Guidelines</b>	<b>30</b>
<b>DMX Traits</b>	<b>35</b>
<b>Color Temperature Control Table</b>	<b>44</b>
<b>FX Generator Guidelines</b>	<b>46</b>
<b>RGBW FX Table</b>	<b>48</b>
<b>Spark LED FX Table</b>	<b>53</b>
<b>Error Codes</b>	<b>58</b>
<b>Specifications</b>	<b>59</b>
<b>Dimensional Drawings</b>	<b>60</b>
<b>Optional Accessories   FCC Statement</b>	<b>61</b>

## INTRODUCTION

Please read and understand the instructions in this manual carefully and thoroughly before attempting to operate this device. These instructions contain important safety and use information. **This device is intended for use by trained personnel only, and is not suitable for private use.**

## UNPACKING

Every device has been thoroughly tested and has been shipped in perfect operating condition. Carefully check the shipping carton for damage that may have occurred during shipping. If the carton is damaged, carefully inspect the device for damage, and be sure all accessories necessary to install and operate the device have arrived intact. In the event that damage has been found or parts are missing, please contact our customer support team for further instructions. Please do not return this device to your dealer without first contacting customer support. Please do not discard the shipping carton in the trash. Please recycle whenever possible.

## IP65 RATED

An IP rated lighting fixture is commonly installed in outdoor environments and has been designed with an enclosure that effectively protects against the ingress (entry) of external foreign objects such as dust and water. The International Protection (IP) rating system is commonly expressed as "IP" followed by two numbers (i.e. IP65) where the numbers define the degree of protection. The first digit (Foreign Bodies Protection) indicates the extent of protection against particles entering the fixture, while the second digit (Water Protection) indicates the extent of protection against water entering the fixture. **An IP65 rated lighting fixture, such as this one, has been designed and tested to protect against the ingress of dust (6) and low-pressure water jets from any direction (5).**

## BOX CONTENTS

Omega Brackets (x2)

IP65 Rated 5-pin DMX Cable (x1)

IP65 Rated RJ45 Data Cable (x1) - **FIXTURE TO FIXTURE INTERCONNECTION USE ONLY!**

IP65 Locking Power Cable (x1)

## CUSTOMER SUPPORT

Contact ELATION Service for any product related service and support needs.

Also visit [forums.elationlighting.com](https://forums.elationlighting.com) with questions, comments or suggestions.

**ELATION SERVICE USA** - Monday - Friday 8:00am to 4:30pm PST  
323-582-3322 | Fax 323-832-9142 | [support@elationlighting.com](mailto:support@elationlighting.com)

**ELATION SERVICE EUROPE** - Monday - Friday 08:30 to 17:00 CET  
+31 45 546 85 63 | Fax +31 45 546 85 96 | [support@elationlighting.eu](mailto:support@elationlighting.eu)

**REPLACEMENT PARTS** - please visit [parts.elationlighting.com](https://parts.elationlighting.com)

## LIMITED WARRANTY (USA ONLY)

- A. Elation Professional hereby warrants, to the original purchaser, Elation Professional products to be free of manufacturing defects in material and workmanship for a period of two years (730 days), and Elation Professional product rechargeable batteries to be free of manufacturing defects in material and workmanship for a period of six months (180 days), from the original date of purchase. This warranty excludes discharge lamps and all product accessories. This warranty shall be valid only if the product is purchased within the United States of America, including possessions and territories. It is the owner's responsibility to establish the date and place of purchase by acceptable evidence, at the time service is sought.
- B. For warranty service, send the product only to the Elation Professional factory. All shipping charges must be pre-paid. If the requested repairs or service (including parts replacement) are within the terms of this warranty, Elation Professional will pay return shipping charges only to a designated point within the United States. If any product is sent, it must be shipped in its original package and packaging material. No accessories should be shipped with the product. If any accessories are shipped with the product, Elation Professional shall have no liability what so ever for loss and/or damage to any such accessories, nor for the safe return thereof.
- C. This warranty is void if the product serial number and/or labels are altered or removed; if the product is modified in any manner which Elation Professional concludes, after inspection, affects the reliability of the product; if the product has been repaired or serviced by anyone other than the Elation Professional factory unless prior written authorization was issued to purchaser by Elation Professional; if the product is damaged because not properly maintained as set forth in the product instructions, guidelines and/or user manual.
- D. This is not a service contract, and this warranty does not include any maintenance, cleaning or periodic check-up. During the periods as specified above, Elation Professional will replace defective parts at its expense, and will absorb all expenses for warranty service and repair labor by reason of defects in material or workmanship. The sole responsibility of Elation Professional under this warranty shall be limited to the repair of the product, or replacement thereof, including parts, at the sole discretion of Elation Professional. All products covered by this warranty were manufactured after January 1, 1990, and bare identifying marks to that effect.
- E. Elation Professional reserves the right to make changes in design and/or performance improvements upon its products without any obligation to include these changes in any products theretofore manufactured.
- F. No warranty, whether expressed or implied, is given or made with respect to any accessory supplied with the products described above. Except to the extent prohibited by applicable law, all implied warranties made by Elation Professional in connection with this product, including warranties of merchantability or fitness, are limited in duration to the warranty periods set forth above. And no warranties, whether expressed or implied, including warranties of merchantability or fitness, shall apply to this product after said periods have expired. The consumer's and/or dealer's sole remedy shall be such repair or replacement as is expressly provided above; and under no circumstances shall Elation Professional be liable for any loss and/or damage, direct and/or consequential, arising out of the use of, and/or the inability to use, this product.
- G. This warranty is the only written warranty applicable to Elation Professional products and supersedes all prior warranties and written descriptions of warranty terms and conditions heretofore published.

## **WARRANTY RETURNS (USA ONLY)**

To obtain warranty service, a Return Materials Authorization (RMA) number must first be obtained from ELATION. It is the Customer's responsibility to provide product proof of purchase and serial number by acceptable evidence such as an invoice copy or an approved ELATION Extended Warranty Certificate ("EWC") and any relevant maintenance records at the time warranty service is sought. Failure to provide acceptable evidence of product proof of purchase or EWC and any relevant maintenance records may be cause for denial of warranty service.

Products returned for warranty service must be sent without any accessories (i.e., power, data, and safety cables, brackets, clamps, rigging hardware, frost filters, gel frames, barn doors, lens, hoses, nozzles, rack mounting hardware, etc.), must be boxed using the original and/or suitable packaging materials (double-box and foam) that provides ample product protection for ground and/or air freight transit, and must be shipped freight pre-paid and insured to ELATION in Los Angeles, CA or an ELATION Authorized Service Center. The RMA number must be clearly written on the outside of the return box, and a brief description of the problem and the RMA number must be documented and included in the box.

Products returned for warranty service without an RMA number clearly marked on the outside of the package will be refused and returned to the shipper at the Customer's expense. Products returned for warranty service, which are received damaged due to inadequate and/or improper packaging and/or due to damage caused by shipping carrier, may incur additional repair charges before warranty service begins and/or may void this warranty. If any product accessories (included and/or optional) are shipped with the product, ELATION and/or the ELATION Authorized Service Center shall have no liability what so ever for the loss and/or damage to any such accessories, nor the safe return thereof. If the requested warranty repairs or service (including parts replacement) are within the terms of this warranty, ELATION will pay return ground transportation shipping charges to a single designated point within the United States.

## **SAFETY PRECAUTIONS**

This fixture is a sophisticated piece of electronic equipment. To guarantee a smooth operation, it is important to follow all instructions and guidelines in this manual. Elation Professional is not responsible for injuries and/or damages resulting from the misuse of this fixture due to the disregard of the information printed in this manual. Only qualified and/or certified personnel should perform installation of this fixture and only the original rigging parts included with this fixture should be used for installation. Any modifications to the fixture and/or the included mounting hardware will void the original manufacturer's warranty and increase the risk of damage and/or personal injury



**PROTECTION CLASS 1 - FIXTURE MUST BE PROPERLY GROUNDED.**



**THERE ARE NO USER SERVICEABLE PARTS INSIDE THIS UNIT. DO NOT ATTEMPT ANY REPAIRS YOURSELF, AS DOING SO WILL VOID YOUR MANUFACTURER'S WARRANTY. DAMAGES RESULTING FROM MODIFICATIONS TO THIS FIXTURE AND/OR THE DISREGARD OF SAFETY INSTRUCTIONS AND GUIDELINES IN THIS MANUAL VOID THE MANUFACTURER'S WARRANTY AND ARE NOT SUBJECT TO ANY WARRANTY CLAIMS AND/OR REPAIRS.**



**DO NOT PLUG FIXTURE INTO A DIMMER PACK!  
NEVER OPEN THIS FIXTURE WHILE IN USE!  
UNPLUG POWER BEFORE SERVICING FIXTURE!  
NEVER TOUCH FIXTURE DURING OPERATION, AS IT MAY BE HOT! KEEP FLAMMABLE MATERIALS AWAY FROM FIXTURE!**



**NEVER LOOK DIRECTLY INTO THE LIGHT SOURCE!  
RETINA INJURY RISK - MAY INDUCE BLINDNESS!  
SENSITIVE PERSONS MAY SUFFER AN EPILEPTIC SHOCK!**



**ENSURE ALL CONNECTIONS AND END CAPS ARE PROPERLY SEALED WITH A DIELECTRIC GREASE (AVAILABLE AT MOST ELECTRICAL SUPPLIERS) TO PREVENT WATER CORROSION AND/OR ELECTRICAL SHORT CIRCUIT.**



**MINIMUM DISTANCE TO OBJECTS/SURFACES  
MUST BE 3.3 FEET (1 METER)  
MAXIMUM TEMP OF EXTERNAL SURFACE 185° F (85°C)  
MINIMUM DISTANCE OF FLAMMABLE MATERIALS FROM THE SURFACE IS 1.6 FEET  
(0.5 METER)**

## **SAFETY PRECAUTIONS**

- DO NOT TOUCH the fixture housing during operation. Turn OFF the power and allow approximately 15 minutes for the fixture to cool down before servicing.
- DO NOT shake fixture, and avoid brute force when installing and/or operating fixture.
- DO NOT operate fixture if the power cord is frayed, crimped, damaged and/or if any of the power cord connectors are damaged and do not insert into the fixture securely with ease.
- NEVER force a power cord connector into the fixture. If the power cord or any of its connectors are damaged, replace it immediately with a new one of the same power rating.
- DO NOT block any air ventilation slots.
- All fan and air inlets must remain clean and never blocked.
- Allow approx. 6" (15cm) between fixture and other devices or a wall for proper cooling.
- Always disconnect fixture from main power source before performing any type of service and/or cleaning procedure.
- Only handle the power cord by the plug end. Never pull out the plug by tugging the wire portion of the cord.
- During the initial operation of this fixture, a light smoke or smell may emit from the interior of the fixture. This is a normal process and is caused by excess paint in the interior of the casing burning off from the heat associated with the lamp and will decrease gradually over time.
- Consistent operational breaks will ensure fixture will function properly for many years.
- ONLY use the original packaging and materials to transport the fixture in for service.

## MAINTENANCE GUIDELINES



**DISCONNECT POWER BEFORE PERFORMING ANY MAINTENANCE!**

### CLEANING

Frequent cleaning is recommended to ensure proper function, optimized light output, and an extended life. The frequency of cleaning depends on the environment in which the fixture operates: damp, smoky or particularly dirty environments can cause greater accumulation of dirt on the fixture's optics. Periodically clean the external lens surface with a soft cloth to avoid dirt/debris accumulation. **NEVER** use alcohol, solvents, or ammonia-based cleaners.

### MAINTENANCE

Regular inspections are recommended to ensure proper function and extended life. There are no user serviceable parts inside this fixture. Please refer all other service issues to an authorized Elation service technician. Should you need any spare parts, please order genuine parts from your local Elation dealer.

Please refer to the following points during routine inspections:

- A detailed electric check by an approved electrical engineer every three months, to make sure the circuit contacts are in good condition and prevent overheating.
- Be sure all screws and fasteners are securely tightened at all times. Loose screws may fall out during normal operation, resulting in damage or injury as larger parts could fall.
- Check for any deformations on the housing, color lenses, rigging hardware, and rigging points (ceiling, suspension, trussing). Deformations in the housing could allow for dust to enter into the fixture. Damaged rigging points or unsecured rigging could cause the fixture to fall and seriously injure a person(s).
- Electric power supply cables must not show any damage, material fatigue or sediments. **NEVER** remove the ground prong from the power cable.

### FIXTURE DISASSEMBLY

The following points should be observed after performing any maintenance procedure that requires disassembly of the unit:

- After the unit has been reassembled, open the valve and allow the unit to run for approximately 2 hours in order to dry out any moisture that has been trapped inside the fixture. The process should continue until indicated humidity drops below 15% for the head and 30% for the base.
- Once this has been achieved, the light can be switched off, but the unit should remain connected to power so that the cooling fan can cool down the unit. Please note that allowing cool down time should **ALWAYS** be done after lamp operation.
- Some units may require partial disassembly in order to gain access to the valve. Please contact Elation service for information regarding the location and access procedure for the valve on your specific unit model.

# OVERVIEW

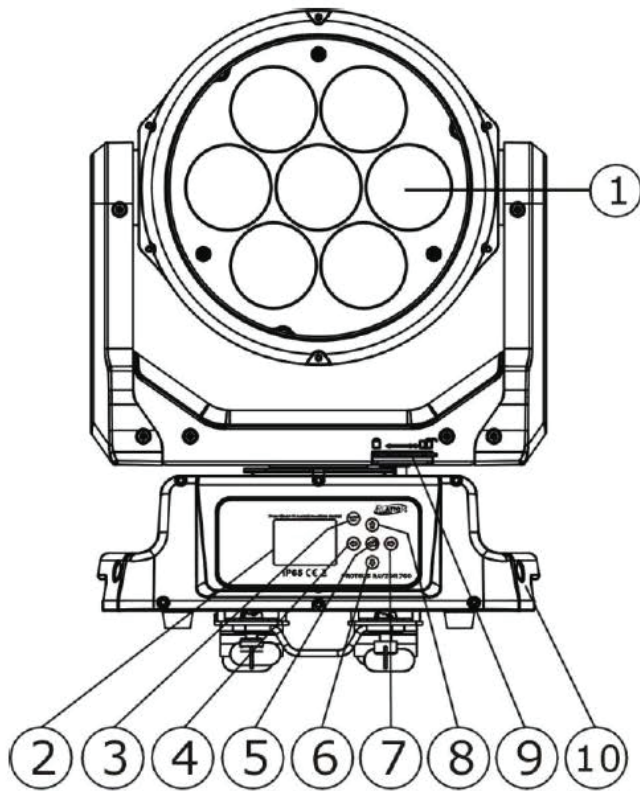

1. Lens
2. System Menu LCD Display
3. Mode/Esc Button
4. Left Button
5. Enter Button
6. Down Button
7. Right Button
8. Up Button
9. Pan Lock
10. Carrying Handle(s)
11. 5-pin DMX Output
12. 5-pin DMX Input
13. RJ45 Output
14. RJ45 Input
15. Fuse
16. Service Port
17. Value
18. Power Input

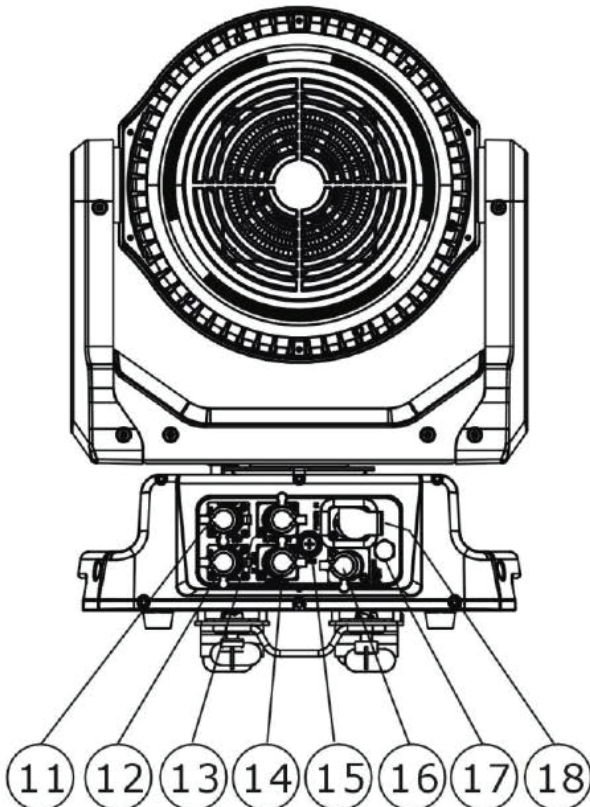

## INSTALLATION GUIDELINES



### FLAMMABLE MATERIAL WARNING

Keep fixture minimum 5.0 feet (1.5m) away from flammable materials and/or pyrotechnics.



### ELECTRICAL CONNECTIONS

A qualified electrician should be used for all electrical connections and/or installations.



**MINIMUM DISTANCE TO SURFACES/OBJECTS IS 3.3 FEET (1 METER).**

**MINIMUM DISTANCE TO FLAMMABLE MATERIALS IS 1.6 FEET (0.5 METER).**

**EXTERNAL SURFACE CAN REACH TEMPERATURES OF 185° F (85° C).**



**DO NOT INSTALL THE FIXTURE IF YOU ARE NOT QUALIFIED TO DO SO!**

Fixture **MUST** be installed following all local, national, and country commercial electrical and construction codes and regulations.

Before rigging/mounting a single fixture or multiple fixtures to any metal truss/structure or placing the fixture(s) on any surface, a professional equipment installer **MUST** be consulted to determine if the metal truss/structure or surface is properly certified to safely hold the combined weight of the fixture(s), clamps, cables, and accessories.

Overhead rigging requires extensive experience, including calculating working load limits, installation material being used, and periodic safety inspection of all installation material and the fixture, among other skills. If you lack these qualifications, do not attempt the installation yourself. Improper installation can result in bodily injury.

Fixture ambient operating temperature range is **-4° to 113°F (-20° to 45°C)**. Do not operate the fixture when the ambient temperature falls outside of this range.

Fixture(s) should be installed away from walking paths, seating areas, or areas where unauthorized personnel might reach the fixture by hand.

**NEVER** stand directly below the fixture(s) when rigging, removing, or servicing.

Overhead fixture installation must always be secured with a secondary safety attachment, such as an appropriately rated safety cable.

Allow approximately 15 minutes for the fixture to cool down before serving.

## INSTALLATION GUIDELINES

### OMEGA BRACKET INSTALLATION

Insert the Omega Brackets into the matching holes on the bottom of the fixture. Secure the Omega Brackets to the fixture by turning each quick-lock fastener  $\frac{1}{4}$  turn clockwise. **Always check to make sure that each fastener is completely locked.** Omega brackets can be installed into the underside of the fixture's base as illustrated below.



### CLAMP INSTALLATION

When mounting the fixture to a truss, be sure to secure appropriately rated professional grade rigging clamps to the included Omega Brackets using an M10 screw fitted through the center hole of the Omega Brackets. **This fixture requires the installation of two Omega brackets and two clamps for secure truss mounting.** The fixture also provides built-in rigging points for a SAFETY CABLE. Be sure to only use the designated rigging point for the safety cable and never secure a safety cable to a carrying handle.



**SAFETY CABLE:  
ALWAYS ATTACH A SAFETY CABLE WHENEVER INSTALLING THIS FIXTURE  
IN A SUSPENDED ENVIRONMENT TO ENSURE THAT THE FIXTURE WILL  
NOT FALL IF THE CLAMP FAILS.**

### ART-NET | sACN CONNECTION

When connecting fixture to a network switch to control multiple devices, a Gigabit Ethernet Switch that supports IGMP (Internet Group Management Protocol) is required. Using a Gigabit Ethernet Switch that does not support IGMP can cause erratic behavior of all connected devices to the switch. Click link below for more information about IGMP.

[https://en.wikipedia.org/wiki/Internet\\_Group\\_Management\\_Protocol](https://en.wikipedia.org/wiki/Internet_Group_Management_Protocol)

# INSTALLATION GUIDELINES

## POWER AND DATA CABLES



TO MAINTAIN THE IP65 RATING INTEGRITY OF THE FIXTURE, ALL CABLES MUST BE RUN TOWARDS THE GROUND IN ORDER TO PREVENT WATER ACCUMULATION AROUND THE CONNECTIONS.

SYSTEM MENU  
LCD DISPLAY

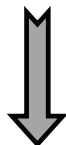
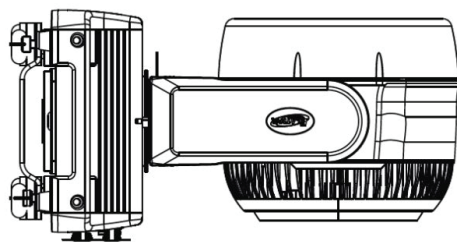
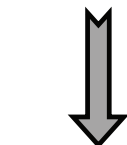

CABLES

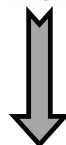
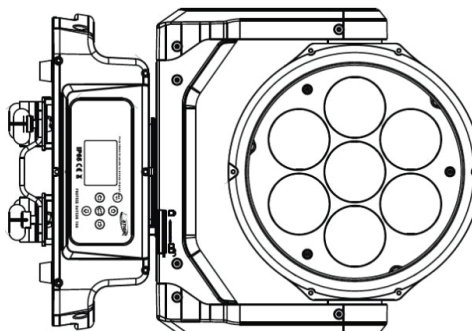

CABLES

## RJ45 DATA CABLES



THE INCLUDED RJ45 DATA CABLE IS FOR FIXTURE TO FIXTURE INTERCONNECTIONS ONLY! THE RJ45 CABLE CONNECTORS MAY NOT BE COMPATIBLE WITH OTHER RJ45 OR ETHERNET TYPE CONNECTORS.

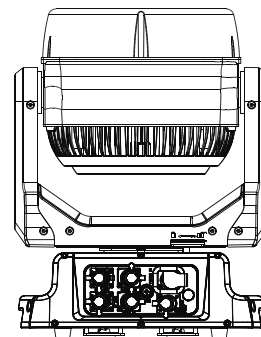
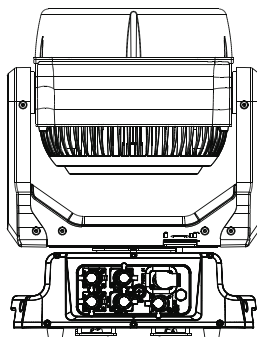
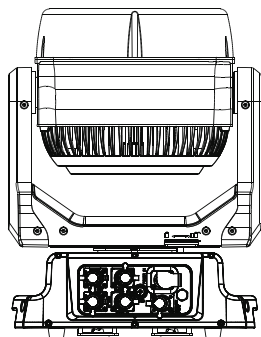

# INSTALLATION GUIDELINES

## POWER AND DATA CONNECTIONS



ENSURE ALL CONNECTIONS AND END CAPS ARE PROPERLY SEALED WITH A DIELECTRIC GREASE (AVAILABLE AT MOST ELECTRICAL SUPPLIERS) IN ORDER TO PREVENT WATER CORROSION AND/OR ELECTRICAL SHORT CIRCUIT.



TO MAINTAIN IP65 RATING INTEGRITY AND PREVENT WATER FROM ENTERING THE FIXTURE, SEAL ALL UNUSED CONNECTION RUBBER CAPS.

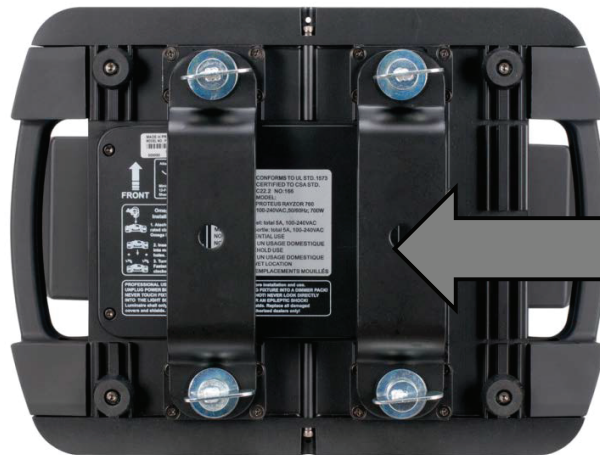

**SAFETY  
CABLE  
LOOP**



ALWAYS ATTACH A SAFETY CABLE WHENEVER INSTALLING THIS DEVICE IN A SUSPENDED ENVIRONMENT TO ENSURE THE FIXTURE WILL NOT FALL IF THE CLAMP FAILS!

# INSTALLATION GUIDELINES

## POTENTIAL INTERNAL FIXTURE DAMAGE FROM EXTERNAL SOURCES OF LIGHT BEAMS

External sources of light beams from direct sunlight, lighting and moving head fixtures, and lasers, which are focused directly towards the exterior housing and/or penetrate the front lens opening of Elation lighting fixtures, can cause severe internal damage including burning of optics, dichroic color filters, glass and metal gobos, prisms, animation wheels, frost filters, iris, shutters, motors, belts, wiring, discharge lamps, and LEDs.

This issue is not specific only to Elation lighting fixtures, but rather it is a common issue with lighting fixtures from all manufacturers. Although there is no true way to fully prevent this issue from happening, the guidelines below can reduce the risk of potential damage. Contact Elation Service for more details.

**DO NOT EXPOSE THE FIXTURE AND/OR FRONT LENS OPENING TO LIGHT BEAMS FROM DIRECT SUNLIGHT, OTHER LIGHTING OR MOVING HEAD FIXTURES, AND LASERS DURING UNPACKING, INSTALLATION, USE, AND EXTENDED IDLE TIMES OUTDOORS. DO NOT FOCUS A LIGHT BEAM FROM ONE LIGHTING FIXTURE DIRECTLY TOWARDS ANOTHER.**

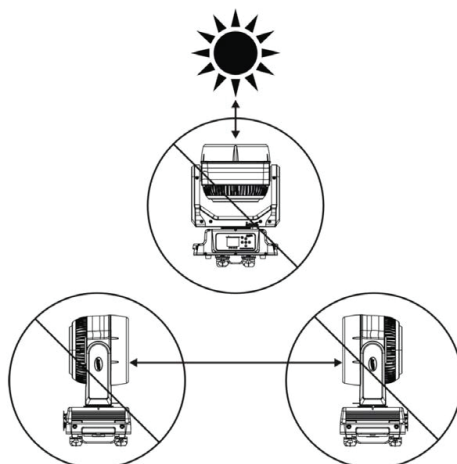

### SUN PROTECTION MODE / HIBERNATION MODE

This state can be set via DMX, or the fixture will go into this state after 3 minutes without a DMX signal.

When the sun protection is activated, the pan-and-tilt function of the moving-head will position the lens away from direct sunlight, or other high intensity light source, to protect the internal belts, electronics etc. from burn damage.

When the unit is in the 'sun protection state', it uses its accelerometer sensors (X-Y-Z) (only present on discharge units and IP units) to position the front lens downwards, even when the unit(s) is moved from its position. This will keep on changing the position of the head.

**Please note that 'manual mode' overrides the 'sun-protection mode'.** The hibernation function is an existing feature that puts the unit into a 'sleep state' to save power (this is a state where only the electronics remain on, and all other functions are turned off). This state is automatically activated when no DMX signal is present for a pre-defined period time (1-99min or off).

## TORQUE SETTINGS FOR SCREWS



PANEL SCREWS MUST BE TIGHTENED WITH A TORQUE WRENCH ACCORDING TO THE TORQUE SPECIFICATION DESCRIBED BELOW.



The hex-head screws holding the panels **MUST** be tightened with a torque wrench. (not included).

**TORQUE SETTING = 11 lbf-in. (12.7kgf-cm)**

## TORQUE SETTINGS FOR SCREWS



**CAUTION! DO NOT OVER TORQUE SCREWS AS THIS CAN CAUSE LEAKAGE ISSUES! TO CONFIRM THE IP65 INTEGRITY AFTER A PROCEDURE REQUIRING DISASSEMBLY/REASSEMBLY, TEST THE FIXTURE USING THE IP TESTER. CONTACT ELATION SERVICE FOR MORE DETAILS.**



**CAUTION! THE USE OF PROTECTIVE GLOVES AND SAFETY GOGGLES IS STRONGLY RECOMMENDED WHILE PERFORMING THE IP PRESSURE TEST! AVOID PLACING YOUR FACE, EYES, HANDS, ETC IN CLOSE PROXIMITY TO THE FIXTURE'S LENS WHILE PERFORMING THE TEST!**



<b>IP PRESSURE TESTING PARAMETERS</b>			
<b>Test Type</b>	<b>Minimum Pressure</b>	<b>Maximum Pressure</b>	<b>Steady/Hold Time</b>
Vacuum Test	-1.88 psi (-13.00 KPa)	-2.46 psi (-17.00 KPa)	10 sec
Pressure Test	1.88 psi (13.00 KPa)	2.46 psi (17.00 KPa)	10 sec

## REMOTE DEVICE MANAGEMENT (RDM)

**NOTE:** In order for RDM to work properly, RDM enabled equipment must be used throughout the entire system, including DMX data splitters and wireless systems.

Remote Device Management (RDM) is a protocol that sits on top of the DMX512 data standard for lighting, allowing the DMX systems of the fixtures to be modified and monitored remotely. This protocol is ideal for instances in which a unit is installed in a location that is not easily accessible.

With RDM, the DMX512 system becomes bi-directional, allowing a compatible RDM enabled controller to send out a signal to devices on the wire, as well as allowing the fixture to respond (known as a GET command). The controller can then use its SET command to modify settings that would typically have to be changed or viewed directly via the unit's display screen, including the DMX Address, DMX Channel Mode, and Temperature Sensors.

### FIXTURE RDM INFORMATION:

RDM Code	Device ID	Device Model ID	Personality ID
0x608	1544	Open	Open

**Please be aware that not all RDM devices support all RDM features,** and therefore it is important to check beforehand to ensure that the equipment that you are considering includes all of the features that you require.

The following parameters are accessible in RDM on this device:

Sensor Definition
Sensor Value
Device Model Description
Manufacturer Label
Device Label
DMX Personality
DMX Personality Description
Device Hours
Lamp Hours
Lamp State
Pan Invert
Tilt Invert
Display Invert

## SYSTEM MENU

The fixture includes an easy to navigate system menu. The control panel (see image below) is located on the front of the fixture and provides access to the main system menu where all necessary system adjustments can be made. During normal operation, pressing MODE/ESC button once will access the fixture's main menu. Once in the main menu, you can navigate through the different functions and access the sub-menus with the UP, DOWN, RIGHT, and LEFT buttons. Once you reach a field that requires adjusting, press the ENTER button to activate that field and use the UP and DOWN buttons to adjust the field. Pressing the ENTER button once more will confirm your setting. You may exit the main menu at any time without making any adjustments by pressing the MODE/ESC button.

To access the LCD Menu Control Display via the internal battery, press and hold the MODE/ESC button for 10 seconds. The LCD Menu Control Display will shut OFF automatically about 1 minute from the last button press.

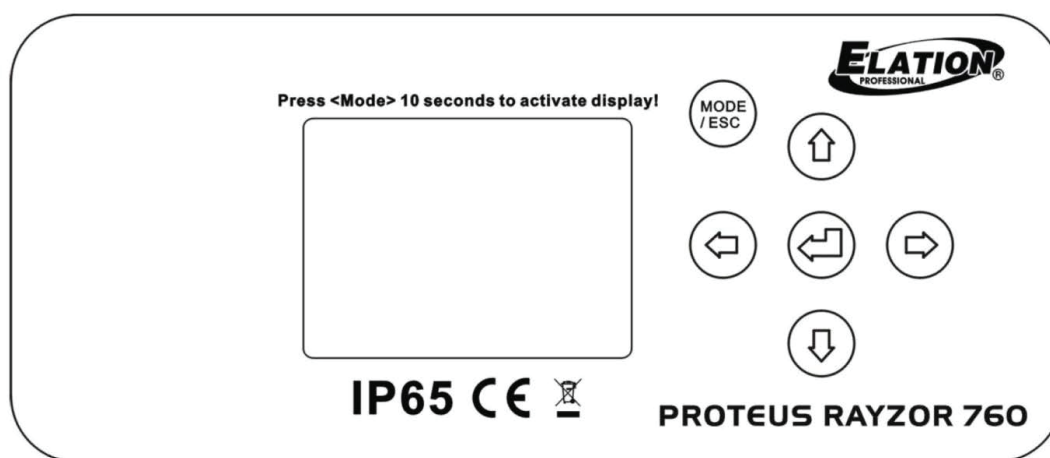

## BATTERY

This unit features a dedicated battery that can be used to power the screen display. This allows the user to configure the device's channel mode, DMX address, or any other screen-accessible features without needing to power on the device or even connect it to a power source. To activate the display on battery power, press and hold the MODE button for 3 seconds.

**ALTHOUGH E-FLY SETTINGS MAY APPEAR IN THE SYSTEM MENU, THIS FEATURE IS NOT ACTIVATED. E-FLY WIRELESS DMX IS AN OPTIONAL FEATURE WHICH MUST BE ACTIVATED IN THE SERVICE MENU. PLEASE CONTACT ELATION SERVICE FOR FURTHER DETAILS.**

# SYSTEM MENU

ELATION PROTEUS RAYZOR 760 SYSTEM MENU					
Supports Software Versions: 1.2.1					
Features subject to change without notice. Rotation direction (clockwise/counter-clockwise) and control of effects depend on head orientation and pan/tilt settings. Default settings listed in <b>bold</b> .					
MAIN MENU	SUB MENU	OPTIONS / VALUES		DESCRIPTION	
FUNCTION	Set DMX Address	A001 - Axxx		Set DMX address	
	DMX Value	All...		Display DMX value	
	Secondary Mode	Secondary1		Active secondary mode and select grouping	
		Secondary2			
Secondary3					
Auto Program	Primary / <b>Alone</b>				
INFORMATION	Time Information	Current Time	xxxx hours	Run hours since fixture was powered on	
		Total Run Time	xxxx hours	Total fixture lifetime run hours	
		Last Run Time	xxxx hours	Run hours since last reset	
		Last Run Password	038		
		Clear Last Run	On / <b>Off</b>	Clear Last Run Time	
	Temperature Info	LED Temperature	xxx C / <b>xxx F</b>		
		Head Temperature	xxx C / <b>xxx F</b>		
		Base Temperature	xxx C / <b>xxx F</b>		
	Humidity Info	Head Humidity	xx %		
		Base Humidity	xx %		
	Ethernet IP	xxx.xxx.xxx.xxx		Displays fixture ethernet address	
	Fan Info	Head Fan 1	xxxx RPM		
			Standby / Fault		
		...	...		
		Head Fan 6	xxxx RPM		
			Standby / Fault		
Base Fan 1		xxxx RPM			
		Standby / Fault			
Base Fan 2	xxxx RPM				
	Standby / Fault				
Software Version	Vx.x.x				
Error Info	Error Record 1 - 10		Displays last 10 error codes		
CONTINUED ON NEXT PAGE					

# SYSTEM MENU

PERSONALITY	Status Settings	Address via DMX	<b>On / Off</b>	
		No DMX Status	Close	
			<b>Hold</b>	
			Auto	
		Pan Reverse	<b>On / Off</b>	
		Tilt Reverse	<b>On / Off</b>	
		Pan Degree	360 / <b>540</b>	
		Tilt Degree	360 / <b>270</b>	
		Pan Tilt Path	Shortest Path	
			<b>Continue Path</b>	
		Feedback	<b>On / Off</b>	
	LED Degree Change	<b>0 / 180</b>		
	Hibernation	Off, 01min - 99min	<b>Default = 15min</b>	
	Service Setting	Password = 050		
		RDM UID	22A6xxxxxxxx	RDM PID Code
		Clear Err Info	<b>On / Off</b>	Clear error info
		USB Update	Yes / <b>No</b>	Service port for software updates
	Fan Control	<b>Auto</b>		
		High		
		Silent		
	Display Setting	Shutoff Time	02min - 60min	<b>Default = 05min</b>
		Display Reverse	<b>On / Off</b>	Flip display 180 degrees
		Key Lock	<b>On / Off</b>	Key Lock
	Temperature C/F	Celsius / <b>Fahrenheit</b>		
	Initial Status	Control = xxx		Initial effect position
	Select Signal	<b>DMX Only</b>		DMX In / Out
		Art-Net		Select Art-Net
		sACN		Activate sACN
	Ethernet IP	xxx.xxx.xxx.xxx		
	Ether Mask IP	xxx.xxx.xxx.xxx		
	Set Universe	<b>000 - 32767</b>		Set ArtNet universe
	Dimmer Mode	<b>Standard</b>		
		Stage		
		TV		
		Architectural		
		Theatre		
		Stage 2		
	Refresh	900Hz - 1500Hz, 2500Hz, 4000Hz, 5000Hz, 6000Hz, 10000Hz, 15000Hz, 20000Hz, 25000Hz		Select LED refresh rate; <b>Default = 1200Hz</b>

CONTINUED ON NEXT PAGE

# SYSTEM MENU

PERSONALITY (continued)	Dimmer Curve	<b>Linear</b>			
		Square			
		Inverse Square			
	S-Curve				
	Reset Default	On / <b>Off</b>	Passcode = 011	Restore to factory settings	
RESET FUNCTION	Reset All				
	Reset Pan & Tilt				
	Reset Others				
EFFECT ADJUST	Test Channel	Pan...		Test each individual function	
	Manual Control	Pan = xxx, ...		Fine adjustment to each function	
	Calibration	Passcode = 050			
USER MODE SET	User Mode	<b>Standard</b>		Select DMX channel mode	
		Pixels			
		Extended			
EDIT PROGRAM	Select Program	Auto Pro Part 1 = Program 1-10 (Program 1)		Select programs to be run	
		Auto Pro Part 2 = Program 1-10 (Program 2)			
		Auto Pro Part 3 = Program 1-10 (Program 3)			
	Edit Program	Program 1	Program Test		Testing program
			Step01 = SCxxx		Program In Loop
			Step64 = SCxxx		Save and exit
		...		...	
		Program 10	Program Test		Testing program
			Step01 = SCxxx		Program In Loop
	Step64 = SCxxx		Save and exit		
	Edit Scenes	Edit Scene 001 ~ Edit Scene 250	Pan, Tilt, ...		Save and automatically return
			--Fade Time-- --Scene Time--		Manual scenes edit
			Input by Outside		Stores scenes via external DMX control
Rec Controller	xx - xx			Automatic scene recorder	

PLEASE CONTINUE TO THE FOLLOWING PAGES TO SEE REVISIONS THAT HAVE BEEN MADE TO THE SYSTEM MENU FOLLOWING THE RELEASE OF THE INITIAL SOFTWARE VERSION.

# SYSTEM MENU

## REVISED SUB MENUS WITH SOFTWARE UPDATE VERSION 1.2.2

See menu items below which have been updated with this software update.

MAIN MENU	SUB MENU	OPTIONS / VALUES	DESCRIPTION	
PERSONALITY	Dimmer Mode	Standard	Set Dimmer Mode	
		Stage		
		TV		
		Architectural		
		Theatre		
		Stage 2		
	Delay Time		0.0 s	Set Delay Time
			0.1 s	
			0.2 s	
			0.3 s	
			0.4 s	
			0.5 s	
			0.6 s	
			0.7 s	
			0.8 s	
			0.9 s	
			1.0 s	
			1.5 s	
			2.0 s	
			2.5 s	
3.0 s				
4.0 s				
5.0 s				
6.0 s				
7.0 s				
8.0 s				
9.0 s				
10.0 s				

# SYSTEM MENU

## REVISED SUB MENUS WITH SOFTWARE UPDATE VERSION 1.3

See menu items below which have been updated with this software update.

MAIN MENU	SUB MENU	OPTIONS / VALUES		DESCRIPTION
PERSONALITY	Status Settings	Address Via DMX	On / Off	Set Dimmer Mode
		No DMX Status	Close	
			Hold	
			Auto	
			<b>SunProt</b>	Sun Protection Mode
		Pan Reverse	On / <b>Off</b>	
		Tilt Reverse	On / <b>Off</b>	
		Pan Tilt Path	Shortest Path	
			<b>Continue Path</b>	
		Feedback	On / Off	
		LED Degree Change	0 / 180	
	Sun Protection	On / Off		
	Hibernation	Off, 01min - 99min	Default = <b>15min</b>	
	...	...	...	...
	Set Universe	000 - 32767		
DHCP	On / <b>Off</b>		Automatic IP address assignment	
Dimmer Mode	...	...	...	
...	...	...	...	

# SYSTEM MENU

ELATION PROTEUS RAYZOR 760 SYSTEM MENU				
Supports Software Versions: 1.3.3				
Features subject to change without notice. Rotation direction (clockwise/counter-clockwise) and control of effects depend on head orientation and pan/tilt settings. Default settings listed in <b>bold</b> .				
MAIN MENU	SUB MENU	OPTIONS / VALUES		DESCRIPTION
FUNCTION	Set DMX Address	A001 - Axxx		Set DMX address
	DMX Value	All...		Display DMX value
	Secondary Mode	Secondary1		Active secondary mode and select grouping
		Secondary2		
		Secondary3		
Auto Program	<b>Primary</b> / Alone			
INFORMATION	Time Information	Current Time	xxxx hours	Run hours since fixture was powered on
		Total Run Time	xxxx hours	Total fixture lifetime run hours
		Last Run Time	xxxx hours	Run hours since last reset
		Last Run Password	038	
		Clear Last Run	On / <b>Off</b>	Clear Last Run Time
	Temperature Info	LED Temperature	xxx C / <b>xxx F</b>	
		Head Temperature	xxx C / <b>xxx F</b>	
		Base Temperature	xxx C / <b>xxx F</b>	
	Humidity Info	Head Humidity	xxx %	
		Base Humidity	xxx %	
	Ethernet IP	Ethernet IP xxx.xxx.xxx.xxx xxx.xxx.xxx.xxx		Displays fixture ethernet address
	Fan Info	Head Fan 1: xxxx RPM ...		Fan speed information
	Software Version	Vx.x.x		
	Error Info	Error Record 1 - 10		Displays last 10 error codes
CONTINUED ON NEXT PAGE				

# SYSTEM MENU

PERSONALITY	Status Settings	Address via DMX	<b>On / Off</b>	
		No DMX Status	Close	
			Hold	
			Auto	
			<b>Sun Prot</b>	
		Pan Reverse	<b>On / Off</b>	
		Tilt Reverse	<b>On / Off</b>	
		Pan Degree	<b>360 / 540</b>	
		Tilt Degree	<b>360 / 270</b>	
		Pan Tilt Path	Shortest Path	
			<b>Continue Path</b>	
		Feedback	<b>On / Off</b>	
	LED Degree Change	<b>0 / 180</b>		
	Hibernation	Off, 01min - 99min	<b>Default = 15min</b>	
	Service Setting	Password = 050		
		Clear Err Info	<b>On / Off</b>	Clear error info
		USB Update	<b>Yes / No</b>	Service port for software updates
	Fan Control	<b>Auto</b>		
		High		
		Silent		
	Display Setting	Shutoff Time	02min - 60min	<b>Default = 05min</b>
		Display Reverse	<b>On / Off</b>	Flip display 180 degrees
		Key Lock	<b>On / Off</b>	Key Lock
	Temperature C/F	<b>Celsius / Fahrenheit</b>		
	Initial Status	Pan = xxx ...		Initial effect position
	Select Signal	<b>DMX Only</b>		DMX In / Out
		Art-Net		Select Art-Net
		sACN		Activate sACN
	Ethernet IP	xxx.xxx.xxx.xxx		Set IP address
	Ether Mask IP	xxx.xxx.xxx.xxx		Set subnet mask
	Set Universe	<b>000 - 32767</b>		Set ArtNet universe
	DHCP	<b>On / Off</b>		Auto assign IP address
Dimmer Mode	<b>Standard</b>			
	Stage			
	TV			
	Architectural			
	Theatre			
	Stage 2			
	0s, 0.1s, 0.2s...10s			
Refresh	900Hz - 1500Hz, 2500Hz, 4000Hz, 5000Hz, 6000Hz, 10000Hz, 15000Hz, 20000Hz, 25000Hz		Select LED refresh rate; <b>Default = 1200Hz</b>	

CONTINUED ON NEXT PAGE

# SYSTEM MENU

PERSONALITY (continued)	Dimmer Curve	<b>Linear</b>			
		Square			
		Inverse Square			
		S-Curve			
	Reset Default	On / <b>Off</b>	Passcode = 011	Restore to factory settings	
RESET FUNCTION	Reset All				
	Reset Pan & Tilt				
	Reset Others				
EFFECT ADJUST	Test Channel	Pan...		Test each individual function	
	Manual Control	Pan = xxx, ...		Fine adjustment to each function	
	Calibration	Passcode = 050 Pan = xxx, ...			
USER MODE SET	User Mode	<b>Standard</b>		Select DMX channel mode	
		Pixels			
		Extended			
EDIT PROGRAM	Select Program	Auto Pro Part 1 = Program 1-10 <b>(Program 1)</b>		Select auto programs to run	
		Auto Pro Part 2 = Program 1-10 <b>(Program 1)</b>			
		Auto Pro Part 3 = Program 1-10 <b>(Program 1)</b>			
	Edit Program	Program 1 - 10	Program Test		Testing program
			Step01 = SCxxx		Program In Loop
			Step64 = SCxxx		Save and exit
	Edit Scenes	Edit Scene 001 ~ Edit Scene 250	Pan, Tilt, ...		Save and automatically return
			--Fade Time-- --Scene Time--		Manual scenes edit
Input by Out			Stores scenes via external DMX control		
Rec Controller	xx - xx		Automatic scene recorder		

# RECORD CONTROLLER

## WORKING WITH BUILT-IN PROGRAMS

A Primary unit can send up to 3 different data groups to the Secondary units. In other words, a Primary unit can operate up to 3 different Secondary units, with each Secondary unit operating a different set of programs. The Primary unit sends the 3 program parts in a continuous loop.

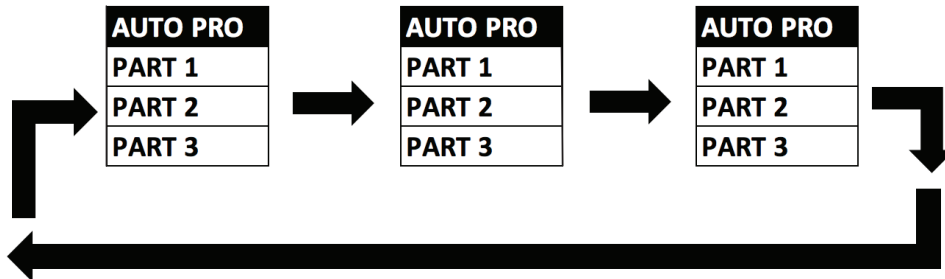

The Secondary unit receives data from the Primary unit according to the group that the Secondary unit was assigned to. For example, suppose we have a unit that has been assigned as a "Secondary 1" unit. Upon receiving the 3-part Auto Program from the Primary unit, the Secondary 1 unit will implement Part 1 of the Auto Program, while ignoring Part 2 and Part 3.

To start running an Auto Program, follow the directions below:

- 1. Set the Secondary unit(s) to the desired Secondary group.** In the main menu of any unit that you want to set as a Secondary, navigate to Function > Secondary Mode. Select "Secondary 1", "Secondary 2", or "Secondary 3" to designate the desired Secondary group. Press ENTER to confirm, and press MODE/ESC to return to the main menu,
- 2. Set the Primary unit.** In the Main Menu of the unit you want to set as the Primary, navigate to Function > Auto Program. Select "Primary" and press ENTER to confirm. Then press MODE/ESC to return to the main menu.
- 3. Program selection for each part of the Auto Program.** In the main menu of the Primary unit, navigate to Edit Program > Select Programs. Select "Auto Pro Part 1", then select which program (1 - 10) to set as Part 1. Press ENTER to confirm. Repeat the process for "Auto Pro Part 2" and "Auto Pro Part 3".
- 4. Program selection for edit program.** In the main menu of the Primary unit, navigate to Edit Program > Edit Program, then press ENTER. Select the desired program to edit specific scenes into a specific program, then press ENTER to confirm.
- 5. Automatic Scene Recording.** In the main menu of the Primary unit, navigate to Edit Program > Edit Scenes, then press ENTER. Select the desired scene numbers, noting that a maximum of 250 scenes can be programmed. Press ENTER to confirm.

See the following page for an example.

# RECORD CONTROLLER

## EXAMPLE: WORKING WITH BUILT-IN PROGRAMS

Program 2 includes scenes: 10, 11, 12, & 13

Program 4 includes scenes: 8, 9, & 10

Program 6 includes scenes: 12, 13, 14, & 15

Auto Pro Part 1 is Program 2

Auto Pro Part 2 is Program 3

Auto Pro Part 3 is Program 6

The 3 Secondary groups run the Auto Program in certain time segments, as illustrated in the diagram below.

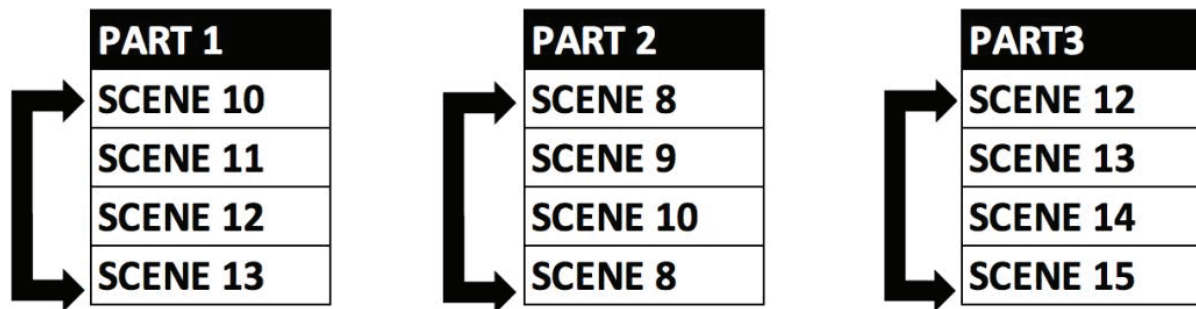

## LIGHTING CONSOLE PATCHING GUIDELINES

The PROTEUS RAYZOR 760 is a versatile luminaire which combines two fixtures into one housing, allowing it to produce multiple unique lighting effects typically not found in a single lighting fixture. The DMX layout is designed to offer a variety of options for controlling each fixture efficiently.

The main fixture contains 7x 60W RGBW pixel cells, while the SparkLED fixture contains 28 x 2W white LEDs. For ease of use the DMX layout is arranged to allow lighting consoles to separate the fixture into multiple segments or parts. It is especially important to arrange the fixture in such segments or parts when using the fixture in the full extended 80 channel DMX mode. For simpler programming, reduced DMX channel modes can be used. However, for easy recall of interesting pixel animations, both the RGBW and SparkLED fixtures contain two FX systems: one which controls the RGBW cells, and a second that is dedicated to the SparkLEDs.

The pixels are arranged in a grid pattern as illustrated below. (RGBW 1-7 | SparkLED 1-28)

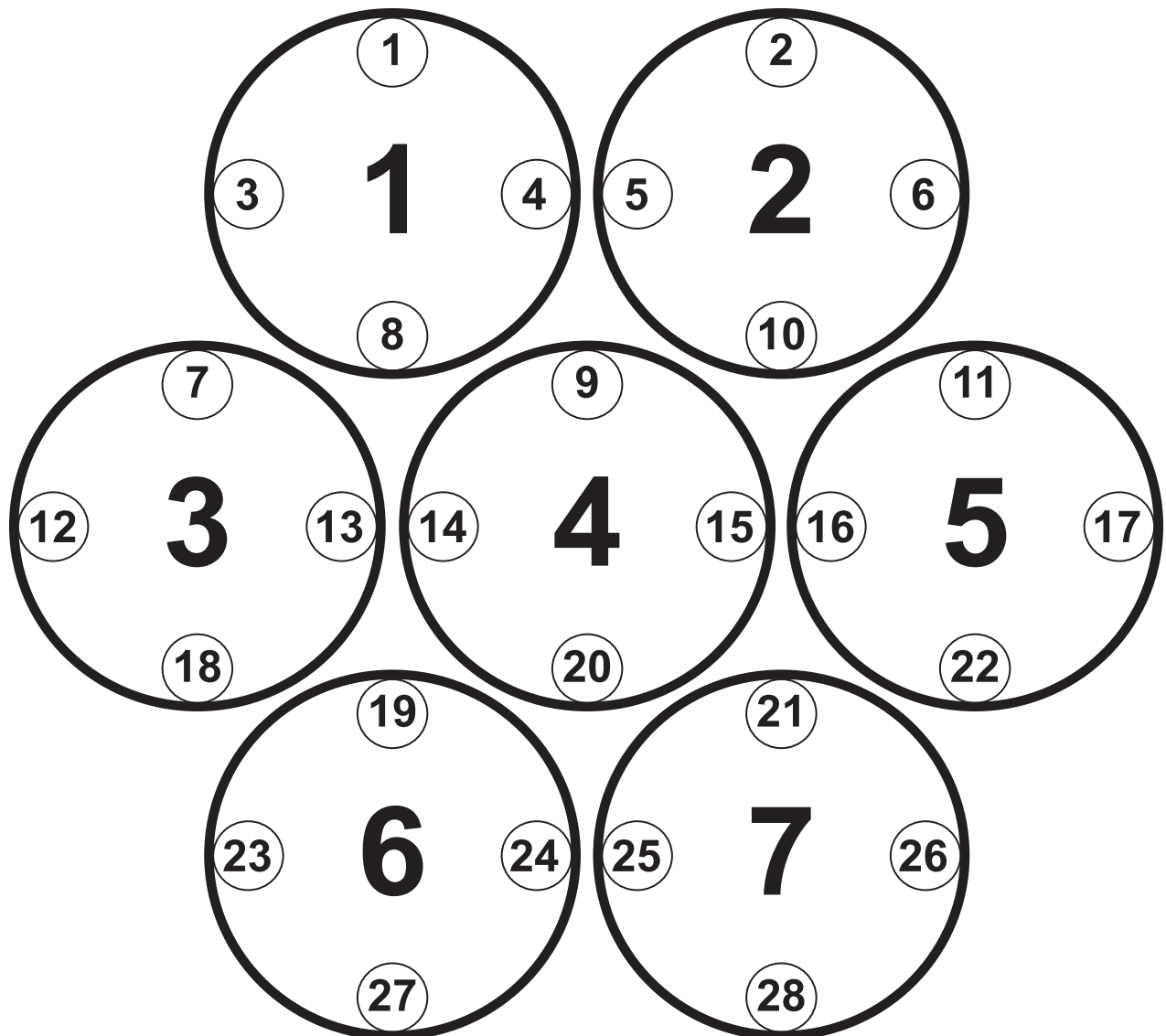

## LIGHTING CONSOLE PATCHING GUIDELINES

PIXEL LAYOUT	PIXEL NUMBERS
RGBW Row 1	1, 2
RGBW Row 2	3, 4, 5
RGBW Row 3	6, 7
RGBW Column 1	3
RGBW Column 2	1, 3, 6
RGBW Column 3	1, 4, 6
RGBW Column 4	4
RGBW Column 5	2, 4, 7
RGBW Column 6	2, 5, 7
RGBW Column 7	5
Spark LED Row 1	1, 2
Spark LED Row 2	3, 4, 5, 6
Spark LED Row 3	7, 8, 9, 10, 11
Spark LED Row 4	12, 13, 14, 15, 16, 17
Spark LED Row 5	18, 19, 20, 21, 22
Spark LED Row 6	23, 24, 25, 26
Spark LED Row 7	27, 28
Spark LED Ring 1	1, 2, 6, 11, 17, 22, 26, 28, 27, 23, 18, 12, 7, 3
Spark LED Ring 2	4, 5, 10, 16, 21, 25, 24, 19, 13, 8
Spark LED Ring 3	9, 15, 20, 14

# LIGHTING CONSOLE PATCHING GUIDELINES

There are also two additional parts for a primary control of the PROTEUS RAYZOR 760, which creates four separate control areas for the fixture. It is recommended to create fixture groups on the lighting controller for each area of the fixture. (see below)

<b>Main Fixture</b>	Primary Pan, Tilt, RGBW Color, Strobe, Dimmer, Zoom, FX Controls
<b>RGBW Cells 1-7</b>	Red, Green, Blue, White per each individual cell
<b>Spark LED Main</b>	Primary Spark LED Strobe, Dimmer
<b>Spark LEDs 1-28</b>	Spark LED Dimmer per each individual LED

**SparkLED is not available as a mode in the fixture menu but must be provided as a console control profile for easy programming of the fixture. Use the PROTEUS RAYZOR 760 in Extended mode and patch appropriate parts of the RGBW Pixels and SparkLED fixtures on your control system to access all 80 channels.**

On the lighting controller, patch the two fixture types (RGBW and SparkLED), separating the SparkLEDs into a different ID range. (see below)

## RGBW Pixels for Channels 1-52

## SparkLEDs for Channels 53-80

**ONLYX** Main and Sub Fixture ID patch example below for a single PROTEUS RAYZOR 760 fixture.

ID	TYPE	ADDRESS
1.0	RGBW Pixels Main	1
1.1	Pixel 1	22
1.2	Pixel 2	26
1.3	Pixel 3	30
1.4	Pixel 4	34
1.5	Pixel 5	38
1.6	Pixel 6	42
1.7	Pixel 7	46
1.8	Spark LED Main	50

101.1	Spark LED 1	53
101.2	Spark LED 2	54
101.3	Spark LED 3	55
101.4	Spark LED 4	56
...	...	...
101.28	Spark LED 28	80

# LIGHTING CONSOLE PATCHING GUIDELINES

**ONLYX** screen shots below illustrate Main and Sub Fixture ID patch for a single PROTEUS RAYZOR 760 fixture.

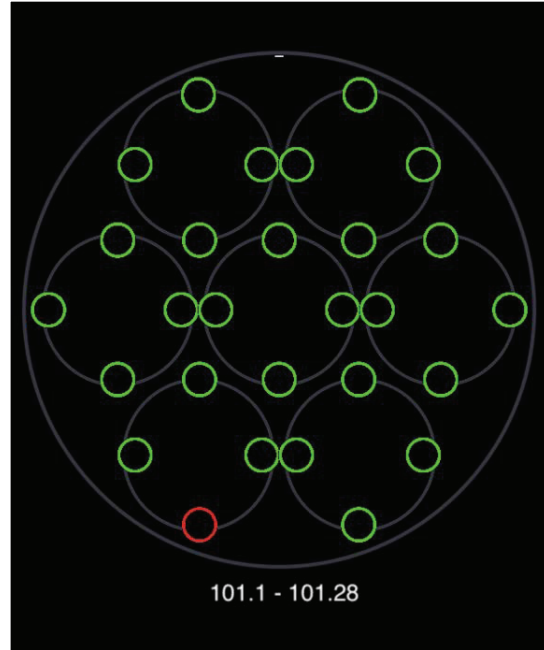
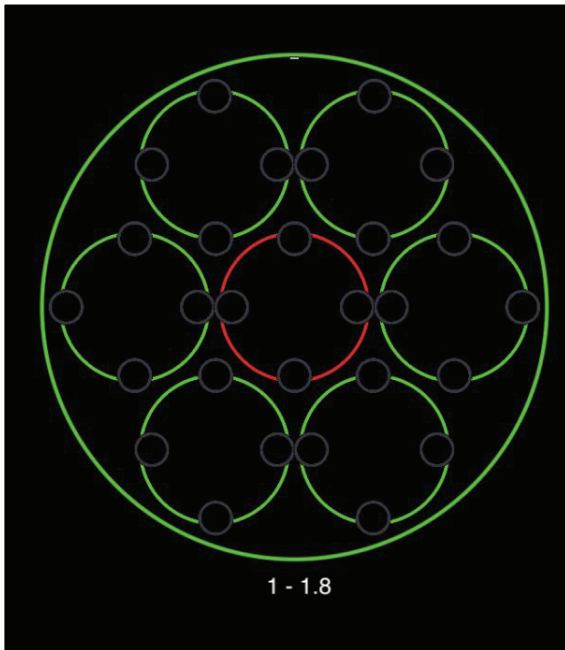

← Back

Tasks

- Patch
- Cloning
- Swap
- RDM

ID	Name	Type	Universe	Address	Invert
1		Rayzor 760 Pixel (Master)	1	1	
1.1		Rayzor 760 Pixel (Pixel 1)	Auto	Auto	
1.2		Rayzor 760 Pixel (Pixel 2)	Auto	Auto	
1.3		Rayzor 760 Pixel (Pixel 3)	Auto	Auto	
1.4		Rayzor 760 Pixel (Pixel 4)	Auto	Auto	
1.5		Rayzor 760 Pixel (Pixel 5)	Auto	Auto	
1.6		Rayzor 760 Pixel (Pixel 6)	Auto	Auto	
1.7		Rayzor 760 Pixel (Pixel 7)	Auto	Auto	
1.8		Rayzor 760 Pixel (SparkLED)	Auto	Auto	
101		Rayzor 760 SparkLED	1	51	
101.1		Rayzor 760 SparkLED (LED 1)	Auto	Auto	
101.2		Rayzor 760 SparkLED (LED 2)	Auto	Auto	
101.3		Rayzor 760 SparkLED (LED 3)	Auto	Auto	
101.4		Rayzor 760 SparkLED (LED 4)	Auto	Auto	
101.5		Rayzor 760 SparkLED (LED 5)	Auto	Auto	
101.6		Rayzor 760 SparkLED (LED 6)	Auto	Auto	
101.7		Rayzor 760 SparkLED (LED 7)	Auto	Auto	
101.8		Rayzor 760 SparkLED (LED 8)	Auto	Auto	
101.9		Rayzor 760 SparkLED (LED 9)	Auto	Auto	
101.10		Rayzor 760 SparkLED (LED 10)	Auto	Auto	
101.11		Rayzor 760 SparkLED (LED 11)	Auto	Auto	
101.12		Rayzor 760 SparkLED (LED 12)	Auto	Auto	
101.13		Rayzor 760 SparkLED (LED 13)	Auto	Auto	
101.14		Rayzor 760 SparkLED (LED 14)	Auto	Auto	
101.15		Rayzor 760 SparkLED (LED 15)	Auto	Auto	
101.16		Rayzor 760 SparkLED (LED 16)	Auto	Auto	
101.17		Rayzor 760 SparkLED (LED 17)	Auto	Auto	
101.18		Rayzor 760 SparkLED (LED 18)	Auto	Auto	
101.19		Rayzor 760 SparkLED (LED 19)	Auto	Auto	
101.20		Rayzor 760 SparkLED (LED 20)	Auto	Auto	
101.21		Rayzor 760 SparkLED (LED 21)	Auto	Auto	
101.22		Rayzor 760 SparkLED (LED 22)	Auto	Auto	
101.23		Rayzor 760 SparkLED (LED 23)	Auto	Auto	
101.24		Rayzor 760 SparkLED (LED 24)	Auto	Auto	
101.25		Rayzor 760 SparkLED (LED 25)	Auto	Auto	
101.26		Rayzor 760 SparkLED (LED 26)	Auto	Auto	
101.27		Rayzor 760 SparkLED (LED 27)	Auto	Auto	
101.28		Rayzor 760 SparkLED (LED 28)	Auto	Auto	

Multi Select  OFF

Change Color

Filter

- All fixture types
- Rayzor 760 Pixel
- Rayzor 760 SparkLED

## LIGHTING CONSOLE PATCHING GUIDELINES

**ONYX** groups example below for easier selection of a single PROTEUS RAYZOR 760 fixture.

Group Name	Group Content
All RGBW Pixels Main	1
All RGBW Pixels	1.1, 1.2, 1.3, ... 1.8
All Spark LEDs Main	1.8
All Spark LEDs	101.1, 101.2, ... 101.28

**ONYX** screen shot below illustrates Groups for a single PROTEUS RAYZOR 760 fixture.

65	All RGBW Pixel Main	66	All RGBW Pixels	67
80	All SparkLED Main	81	All SparkLEDs	82
95		96		97

# DMX TRAITS

ELATION PROTEUS RAYZOR 760 DMX Channel Traits							
Supports Software Versions: 1.2.1							
Features subject to change without notice. Rotation direction (clockwise/counter-clockwise) and control of effects depends on head orientation and pan/tilt settings.							
CHANNEL				DMX VALUES	FUNCTION	FADE STATUS	DE-FAULT VALUE
STANDARD	PIXELS	EXTENDED	SPARK LED				
MAIN FIXTURE CONTROL							
1	1	1		000 - 255	<b>Pan</b>	Fade	127
2	2	2		000 - 255	<b>Pan Fine</b>	Fade	127
3	3	3		000 - 255	<b>Tilt</b>	Fade	127
4	4	4		000 - 255	<b>Tilt Fine</b>	Fade	127
5	5	5			<b>Pan Rotate</b>	Fade	0
				000 - 002	Disabled		
				003 - 126	Rotating Clockwise, fast to slow		
				127 - 129	No Rotation		
				130 - 253	Rotating Counter-Clockwise, slow to fast		
				254 - 255	No Rotation		
6	6	6			<b>Tilt Rotate</b>	Fade	0
				000 - 002	Disabled		
				003 - 126	Rotating Clockwise, fast to slow		
				127 - 129	No Rotation		
				130 - 253	Rotating Counter-Clockwise, slow to fast		
				254 - 255	No Rotation		
7	7	7			<b>CTC</b>	Fade	0
				000 - 010	Disabled		
				011 - 171	Color Temperature, 2000K to 10,000K in 100K steps (see <b>CTC Table</b> section of this manual)		
				172 - 255	10,000K		
8	8	8			<b>Color Wheel</b>	Snap	0
				000 - 009	Open		
				010 - 014	Red		
				015 - 019	Red Orange		
				020 - 024	Light Amber		
				025 - 029	Yellow Amber		
				030 - 034	Greenish Yellow		
				035 - 039	Light Yellow Green		
				040 - 044	Dark Yellow Green		
045 - 049	Green						

CONTINUED ON NEXT PAGE

# DMX TRAITS

CHANNEL				DMX VALUES	FUNCTION	FADE STATUS	DE-FAULT VALUE
STANDARD	PIXELS	EXTENDED	SPARK LED				
8	8	8			<b>Color Wheel (continued)</b>	Snap	0
				050 - 054	Teal		
				055 - 059	Cyan		
				060 - 064	Light Blue		
				065 - 069	Aqua		
				070 - 074	Dark Aqua		
				075 - 079	Green Blue		
				080 - 084	Light Lavender		
				085 - 089	Dark Purple		
				090 - 094	Medium Purple		
				095 - 099	Mid Rose		
				100 - 104	Mauve		
				105 - 109	Nice Magenta		
				110 - 114	Warm Magenta		
				115 - 119	Light Red		
				120 - 124	Straw		
				125 - 129	Dark CTB		
				130 - 134	Light Green		
				135 - 139	Purple		
				140 - 144	Lighter Purple		
				145 - 149	Pink		
				150 - 154	Rose		
				155 - 159	Rose		
				160 - 174	Not in use		
				175 - 179	Open		
					<b>Color Scroll</b>		
				180 - 201	Clockwise, fast to slow		
				202 - 207	Stop		
				208 - 229	Counter-Clockwise, slow to fast		
				230 - 234	Open		
	<b>Random Slots</b>						
235 - 239	Fast						
240 - 244	Medium						
245 - 249	Slow						
250 - 255	Open						

CONTINUED ON NEXT PAGE

# DMX TRAITS

CHANNEL				DMX VALUES	FUNCTION	FADE STATUS	DE-FAULT VALUE
STANDARD	PIXELS	EXTENDED	SPARK LED				
9	9	9			<b>Strobe</b>	Snap	50
				000 - 031	Shutter Closed		
				032 - 063	Shutter Open		
				064 - 095	Strobe, slow to fast		
				096 - 127	Fast Close, Slow Open		
				128 - 159	Fast Open, Slow Close		
				160 - 191	Pulse Effects		
				192 - 223	Random Strobe, slow to fast		
	224 - 255	Shutter Open					
10	10	10		000 - 255	<b>Dimmer</b> , 0% to 100%	Fade	0
11	11	11		000 - 255	<b>Dimmer Fine</b>	Fade	0
12	12	12			<b>Dim Modes</b>	Snap	0
				000 - 020	Standard		
				021 - 040	Stage		
				041 - 060	TV		
				061 - 080	Architectural		
				081 - 100	Theatre		
				101 - 120	Stage 2		
					<b>Dimmer Delay Time</b>		
				121	0 s		
				122	0.1 s		
				123	0.2 s		
				124	0.3 s		
				125	0.4 s		
				126	0.5 s		
				127	0.6 s		
				128	0.7 s		
				129	0.8 s		
				130	0.9 s		
				131	1.0 s		
				132	1.5 s		
133	2.0 s						
134	3.0 s						
135	4.0 s						
136	5.0 s						
137	6.0 s						
138	7.0 s						
139	8.0 s						

CONTINUED ON NEXT PAGE

# DMX TRAITS

CHANNEL				DMX VALUES	FUNCTION	FADE STATUS	DE-FAULT VALUE
STANDARD	PIXELS	EXTENDED	SPARK LED				
12	12	12			<b>Dimmer Delay Time (continued)</b>	Snap	0
				140	9.0 s		
				141	10.0 s		
				142 - 255	Idle		
13	13	13			<b>Zoom</b>	Fade	128
				000 - 215	Zoom, wide to narrow		
				215 - 255	Overdrive, minimum to maximum		
	14	14		000 - 255	<b>Zoom Fine</b>	Fade	0
	15	15			<b>Pan / Tilt Speed</b>	Snap	0
				000 - 225	Max to Min Speed		
				226 - 235	Blackout when pan / tilt moves		
				236 - 245	Blackout when all wheels change		
				246 - 255	No function		
14	16	16			<b>Control</b>	Snap	0
				000 - 010	Idle		
				011 - 012	Pan Tilt Shortest Path		
				013 - 014	Pan Tilt Continue Path		
				015 - 016	Pan Range 540		
				017 - 018	Pan Range 360		
				019 - 020	Tilt Range 270		
				021 - 022	Tilt Range 360		
				023 - 039	Idle		
				040 - 059	Fan Mode Silent		
				060 - 079	Fan Mode Auto		
				080 - 084	Reset All		
				085 - 087	Reset Movement		
				088 - 091	Reset Zoom		
				092 - 099	Idle		
					<b>Refresh Rate (Hz)</b>		
				100	900		
				101	910		
				102	920		
103	930						
104	940						
105	950						
106	960						
107	970						

CONTINUED ON NEXT PAGE

# DMX TRAITS

CHANNEL				DMX VALUES	FUNCTION	FADE STATUS	DE-FAULT VALUE
STANDARD	PIXELS	EXTENDED	SPARK LED				
14	16	16			Refresh Rate (Hz) (continued)	Snap	0
				108	980		
				109	990		
				110	1000		
				111	1010		
				112	1020		
				113	1030		
				114	1040		
				115	1050		
				116	1060		
				117	1070		
				118	1080		
				119	1090		
				120	1100		
				121	1110		
				122	1120		
				123	1130		
				124	1140		
				125	1150		
				126	1160		
				127	1170		
				128	1180		
				129	1190		
				130	1200		
				131	1210		
				132	1220		
				133	1230		
				134	1240		
				135	1250		
				136	1260		
				137	1270		
				138	1280		
139	1290						
140	1300						
141	1310						
142	1320						
143	1330						
144	1340						
145	1350						
146	1360						

CONTINUED ON NEXT PAGE

# DMX TRAITS

CHANNEL				DMX VALUES	FUNCTION	FADE STATUS	DE-FAULT VALUE
STANDARD	PIXELS	EXTENDED	SPARK LED				
14	16	16			Refresh Rate (Hz) (continued)	Snap	0
				147	1370		
				148	1380		
				149	1390		
				150	1400		
				151	1410		
				152	1420		
				153	1430		
				154	1440		
				155	1450		
				156	1460		
				157	1470		
				158	1480		
				159	1490		
				160	1500		
				161	2500		
				162	4000		
				163	5000		
				164	6000		
				165	10000		
				166	15000		
				167	20000		
				168	25000		
				169 - 200	Idle		
				<b>ADDED WITH SOFTWARE UPDATE 1.2.2</b>			
				169 - 192	Idle		
				193 - 194	Hibernate Off		
				195 - 196	Hibernate		
197 - 198	Home Position Before Power Off						
199 - 200	Home Position Off						
201 - 210	Dimmer Curve Linear (default)						
211 - 220	Dimmer Curve Square						
221 - 230	Dimmer Curve Inverse Square						
231 - 240	Dimmer Curve S-Curve						
241 - 255	Idle						

CONTINUED ON NEXT PAGE

# DMX TRAITS

CHANNEL				DMX VALUES	FUNCTION	FADE STATUS	DE-FAULT VALUE
STANDARD	PIXELS	EXTENDED	SPARK LED				
15	17	17		000 - 255	<b>RGBW FX Table</b> , FX selection 1 - 255 (see <b>RGBW FX Table</b> section of this manual)	Snap	0
16	18	18			<b>RGBW FX Speed</b>	Fade	160
				000 - 126	Rev fast to slow		
				127 - 128	Stop		
				129 - 255	slow to fast		
17	19	19		000 - 255	<b>Spark LED FX Selection</b> , 1 - 255 (see <b>Spark LED FX Table</b> section of this manual)	Snap	0
18	20	20			<b>Spark LED FX Speed</b>	Fade	160
				000 - 126	Rev, fast to slow		
				127 - 128	Stop		
				129 - 255	Slow to fast		
19	21	21			<b>FX Offset</b>	Snap	0
				000	No Sync		
				001 - 035	Fixture offset, 10 degrees to 350 degrees		
				036	Synchronized		
				037 - 100	No Function		
				101 - 120	Random Fixtures		
				121 - 140	Random Duration		
				141 - 255	Random Pixels		
20	22	22		000 - 255	<b>Red</b> , 0% to 100%	Fade	255
21	23	23		000 - 255	<b>Green</b> , 0% to 100%	Fade	255
22	24	24		000 - 255	<b>Blue</b> , 0% to 100%	Fade	255
23	25	25		000 - 255	<b>White</b> , 0% to 100%	Fade	255
	26	26		000 - 255	<b>Red 2</b> , 0% to 100%	Fade	255
	27	27		000 - 255	<b>Green 2</b> , 0% to 100%	Fade	255
	28	28		000 - 255	<b>Blue 2</b> , 0% to 100%	Fade	255
	29	29		000 - 255	<b>White 2</b> , 0% to 100%	Fade	255
	30	30		000 - 255	<b>Red 3</b> , 0% to 100%	Fade	255
	31	31		000 - 255	<b>Green 3</b> , 0% to 100%	Fade	255
	32	32		000 - 255	<b>Blue 3</b> , 0% to 100%	Fade	255
	33	33		000 - 255	<b>White 3</b> , 0% to 100%	Fade	255
	34	34		000 - 255	<b>Red 4</b> , 0% to 100%	Fade	255
	35	35		000 - 255	<b>Green 4</b> , 0% to 100%	Fade	255
	36	36		000 - 255	<b>Blue 4</b> , 0% to 100%	Fade	255
	37	37		000 - 255	<b>White 4</b> , 0% to 100%	Fade	255
	38	38		000 - 255	<b>Red 5</b> , 0% to 100%	Fade	255

CONTINUED ON NEXT PAGE

# DMX TRAITS

CHANNEL				DMX VALUES	FUNCTION	FADE STATUS	DE-FAULT VALUE
STANDARD	PIXELS	EXTENDED	SPARK LED				
	39	39		000 - 255	<b>Green 5</b> , 0% to 100%	Fade	255
	40	40		000 - 255	<b>Blue 5</b> , 0% to 100%	Fade	255
	41	41		000 - 255	<b>White 5</b> , 0% to 100%	Fade	255
	42	42		000 - 255	<b>Red 6</b> , 0% to 100%	Fade	255
	43	43		000 - 255	<b>Green 6</b> , 0% to 100%	Fade	255
	44	44		000 - 255	<b>Blue 6</b> , 0% to 100%	Fade	255
	45	45		000 - 255	<b>White 6</b> , 0% to 100%	Fade	255
	46	46		000 - 255	<b>Red 7</b> , 0% to 100%	Fade	255
	47	47		000 - 255	<b>Green 7</b> , 0% to 100%	Fade	255
	48	48		000 - 255	<b>Blue 7</b> , 0% to 100%	Fade	255
	49	49		000 - 255	<b>White 7</b> , 0% to 100%	Fade	255

## SPARK LED CONTROL

Spark LED is not available as a mode in the fixture menu, but must be provided as a console control profile for easy programming of the fixture. Use this fixture in Extended mode and patch appropriate parts of the RGBW pixels and Spark LED fixtures on your control system to access all 80 channels. See the **Lighting Console Patch Guidelines** section of this manual for further instructions.

24	50	50			<b>Strobe</b>	Snap	50
				000 - 031	Shutter Closed		
				032 - 063	Shutter Open		
				064 - 095	Strobe, slow to fast		
				096 - 127	Fast Close, Slow Open		
				128 - 159	Fast Open, Slow Close		
				160 - 191	Pulse Effects		
				192 - 223	Random Strobe All, slow to fast		
				224 - 255	Random Strobe Pixels, slow to fast		
25	51	51		000 - 255	<b>Dimmer</b> , 0% to 100%	Fade	0
	52	52		000 - 255	<b>Dimmer Fine</b>	Fade	0
		53	1	000 - 255	<b>Spark LED #1 Dimmer</b> , 0% to 100%	Fade	255
		54	2	000 - 255	<b>Spark LED #2 Dimmer</b> , 0% to 100%	Fade	255
		55	3	000 - 255	<b>Spark LED #3 Dimmer</b> , 0% to 100%	Fade	255
		56	4	000 - 255	<b>Spark LED #4 Dimmer</b> , 0% to 100%	Fade	255
		57	5	000 - 255	<b>Spark LED #5 Dimmer</b> , 0% to 100%	Fade	255
		58	6	000 - 255	<b>Spark LED #6 Dimmer</b> , 0% to 100%	Fade	255
		59	7	000 - 255	<b>Spark LED #7 Dimmer</b> , 0% to 100%	Fade	255

CONTINUED ON NEXT PAGE

# DMX TRAITS

CHANNEL				DMX VALUES	FUNCTION	FADE STATUS	DE-FAULT VALUE
STANDARD	PIXELS	EXTENDED	SPARK LED				
		60	8	000 - 255	<b>Spark LED #8 Dimmer, 0% to 100%</b>	Fade	255
		61	9	000 - 255	<b>Spark LED #9 Dimmer, 0% to 100%</b>	Fade	255
		62	10	000 - 255	<b>Spark LED #10 Dimmer, 0% to 100%</b>	Fade	255
		63	11	000 - 255	<b>Spark LED #11 Dimmer, 0% to 100%</b>	Fade	255
		64	12	000 - 255	<b>Spark LED #12 Dimmer, 0% to 100%</b>	Fade	255
		65	13	000 - 255	<b>Spark LED #13 Dimmer, 0% to 100%</b>	Fade	255
		66	14	000 - 255	<b>Spark LED #14 Dimmer, 0% to 100%</b>	Fade	255
		67	15	000 - 255	<b>Spark LED #15 Dimmer, 0% to 100%</b>	Fade	255
		68	16	000 - 255	<b>Spark LED #16 Dimmer, 0% to 100%</b>	Fade	255
		69	17	000 - 255	<b>Spark LED #17 Dimmer, 0% to 100%</b>	Fade	255
		70	18	000 - 255	<b>Spark LED #18 Dimmer, 0% to 100%</b>	Fade	255
		71	19	000 - 255	<b>Spark LED #19 Dimmer, 0% to 100%</b>	Fade	255
		72	20	000 - 255	<b>Spark LED #20 Dimmer, 0% to 100%</b>	Fade	255
		73	21	000 - 255	<b>Spark LED #21 Dimmer, 0% to 100%</b>	Fade	255
		74	22	000 - 255	<b>Spark LED #22 Dimmer, 0% to 100%</b>	Fade	255
		75	23	000 - 255	<b>Spark LED #23 Dimmer, 0% to 100%</b>	Fade	255
		76	24	000 - 255	<b>Spark LED #24 Dimmer, 0% to 100%</b>	Fade	255
		77	25	000 - 255	<b>Spark LED #25 Dimmer, 0% to 100%</b>	Fade	255
		78	26	000 - 255	<b>Spark LED #26 Dimmer, 0% to 100%</b>	Fade	255
		79	27	000 - 255	<b>Spark LED #27 Dimmer, 0% to 100%</b>	Fade	255
		80	28	000 - 255	<b>Spark LED #28 Dimmer, 0% to 100%</b>	Fade	255

## COLOR TEMPERATURE CONTROL TABLE

COLOR TEMP	DMX VALUE
2000	011
2050	012
2100	013
2150	014
2200	015
2250	016
2300	017
2350	018
2400	019
2450	020
2500	021
2550	022
2600	023
2650	024
2700	025
2750	026
2800	027
2850	028
2900	029
2950	030
3000	031
3050	032
3100	033
3150	034
3200	035
3250	036
3300	037
3350	038
3400	039
3450	040
3500	041
3550	042
3600	043
3650	044
3700	045
3750	046
3800	047
3850	048
3900	049
3950	050
4000	051
4050	052
4100	053

COLOR TEMP	DMX VALUE
4150	054
4200	055
4250	056
4300	057
4350	058
4400	059
4450	060
4500	061
4550	062
4600	063
4650	064
4700	065
4750	066
4800	067
4850	068
4900	069
4950	070
5000	071
5050	072
5100	073
5150	074
5200	075
5250	076
5300	077
5350	078
5400	079
5450	080
5500	081
5550	082
5600	083
5650	084
5700	085
5750	086
5800	087
5850	088
5900	089
5950	090
6000	091
6050	092
6100	093
6150	094
6200	095
6250	096

## COLOR TEMPERATURE CONTROL TABLE

COLOR TEMP	DMX VALUE
6300	097
6350	098
6400	099
6450	100
6500	101
6550	102
6600	103
6650	104
6700	105
6750	106
6800	107
6850	108
6900	109
6950	110
7000	111
7050	112
7100	113
7150	114
7200	115
7250	116
7300	117
7350	118
7400	119
7450	120
7500	121
7550	122
7600	123
7650	124
7700	125
7750	126
7800	127
7850	128
7900	129
7950	130
8000	131
8050	132
8100	133
8150	134
8200	135
8250	136
8300	137
8350	138
8400	139





COLOR TEMP	DMX VALUE
8450	140
8500	141
8550	142
8600	143
8650	144
8700	145
8750	146
8800	147
8850	148
8900	149
8950	150
9000	151
9050	152
9100	153
9150	154
9200	155
9250	156
9300	157
9350	158
9400	159
9450	160
9500	161
9550	162
9600	163
9650	164
9700	165
9750	166
9800	167
9850	168
9900	169
9950	170
10000	171

## FX GENERATOR GUIDELINES

Selection and control of the integrated FX on the PROTUES RAYZOR 760 is found in the Main Fixture section. All FX are available even in the smallest DMX control modes. (see below)

DMX VALUES	FUNCTION
000 - 255	<b>RGBW FX Selection, 1 - 255</b> (see RGBW FX Table)
	<b>RGBW FX Speed</b>
000 - 126	Rev, fast to slow
127 - 128	Stop
129 - 255	Slow to fast
000 - 255	<b>Spark LED FX Selection, 1 - 255,</b> (see Spark LED FX Table)
	<b>Spark LED FX Speed</b>
000 - 126	Rev, fast to slow
127 - 128	Stop
129 - 255	Slow to fast

FX for RGBW and SparkLED contain a selection channel to recall the desired pattern. The pattern direction and speed is then adjusted using the associated Speed channels. FX can run forward or reverse and can also be frozen at any time by using "Stop". The FX tables show the available patterns which are grouped for easier browsing. The first 10 DMX steps of the FX channel are used to change the type of curve for smooth or stepped FX. Once a curve is selected, it will be used for all FX recalled afterwards. When programming curves for fixtures, the user must ensure to change the curve first before selecting the pattern. The fixture defaults to the Sinewave pattern after every power cycle. (see below)

<b>Sinewave (default)</b>	
<b>Step</b>	
<b>Sawtooth</b>	 Ramp Up
<b>Ramp Up</b>	
<b>Ramp Down</b>	

## FX GENERATOR GUIDELINES

In addition to FX direction and speed control, a Sync channel allows to offset or randomize the fixtures or the FX steps. (see below)

DMX VALUES	FUNCTION
	<b>FX Offset</b>
000	No Sync
001 - 035	Fixture Offset, 10 degrees to 350 degrees
036	Synchronized
037 - 100	No Function
101 - 120	Random Fixture Offset
121 - 140	Random Pixel Order
141 - 255	Random Steps

A full FX cycle is 360 degrees, and the fixture offsets can be set in 10-degree increments. Offsetting a fixture by 180 would mean it is exactly halfway ahead through the FX cycle.

Three randomization options are provided:

### **Random Fixture Offset**

Every fixture randomly selects any of the 36 offset points. It will then use this until the offset is changed or random offset is selected again.

### **Random Pixel Order**

The actual FX steps are randomized. This shuffling of the fixture order is done once, then the fixture will use this shuffled order across all FX until changed.







### **Random Steps**

Every step is randomly chosen every time, giving the most random sequence possible.

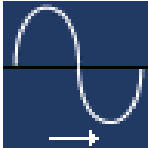
To reshuffle the randomization, set the channel to Idle and reselect the desired random option.



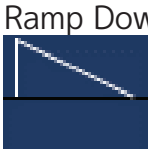
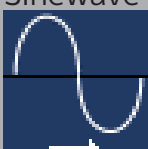

The FX system of the PROTEUS RAYZOR 760 allows many different combinations by changing the curves, offsets and speed parameters. The RGBW and SparkLED systems are separate, and by adjusting color, dimming and strobe channels there are endless creative designs possible.

# RGBW FX TABLE

TYPE	SLOT	DMX VALUES	NAME	FX ADJUSTMENT	
Waveform	0	000	Off		
	1	001	Sinewave (default) 		
	2	002	Step 		
	3	003	Sawtooth 		
	4	004	Ramp Up 		
	5	005	Ramp Down 		
	6-10	006 - 010	No Function		
	<b>REVISED WITH SOFTWARE UPDATE VERSION 1.2.2</b>				
	0	000	Off		
	1	001	Sinewave Cross (default) 		
2	002	Sinewave Full 			

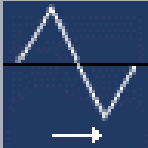
CONTINUED ON NEXT PAGE

# RGBW FX TABLE

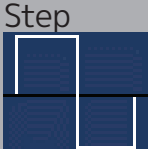
TYPE	SLOT	DMX VALUES	NAME	FX ADJUSTMENT
<b>REVISED WITH SOFTWARE UPDATE VERSION 1.2.2</b>				
<b>Waveform (continued)</b>	3	003	Sawtooth Cross 	
	4	004	Sawtooth Full 	
	5	005	Ramp Up 	
	6	006	Ramp Down 	
	7	007	Step 	
	8-10	008 - 010	No Function	
	<b>Intensity</b>	11	011	Single
12		012	Single Bounce	Reverse, Stop, Forward
13		013	Snake	Reverse, Stop, Forward
14		014	Snake Bounce	Reverse, Stop, Forward
15		015	Rows	Reverse, Stop, Forward
16		016	Rows Bounce	Reverse, Stop, Forward
17		017	Column	Reverse, Stop, Forward
18		018	Column Bounce	Reverse, Stop, Forward
19		019	Columns 2	Reverse, Stop, Forward
20		020	Slash	Reverse, Stop, Forward
21		021	Backslash	Reverse, Stop, Forward
22		022	Slash Back	Reverse, Stop, Forward
23	023	<>	Reverse, Stop, Forward	

CONTINUED ON NEXT PAGE

# RGBW FX TABLE

TYPE	SLOT	DMX VALUES	NAME	FX ADJUSTMENT
Intensity (continued)	24	024	><	Reverse, Stop, Forward
	25	025	>>	Reverse, Stop, Forward
	26	026	<<	Reverse, Stop, Forward
	27	027	Rotating Bar	Reverse, Stop, Forward
	28	028	Rotating Dot	Reverse, Stop, Forward
	29	029	Rotating 2 Dot	Reverse, Stop, Forward
	30	030	Ring 2 Cell	Reverse, Stop, Forward
	31	031	Ring 2 Cell Overlap	Reverse, Stop, Forward
	32	032	Ring 3 Cell Blend	Reverse, Stop, Forward
	33	033	Ring - Center Fade	Reverse, Stop, Forward
	34	034	X-Bar	Reverse, Stop, Forward
	35	035	Diagonals	Reverse, Stop, Forward
	36	036	Arrow Left	Reverse, Stop, Forward
	37	037	Arrow Right	Reverse, Stop, Forward
	38	038	2 Pixels	Reverse, Stop, Forward
	39	039	3 Pixels	Reverse, Stop, Forward
	40	040	4 Pixels	Reverse, Stop, Forward
	41	041	1, 2, 3, 4 Pixels	Reverse, Stop, Forward
	42	042	Ring Build	Reverse, Stop, Forward
	43	043	Ring Build Erase	Reverse, Stop, Forward
	44	044	Ring Build Erase 2	Reverse, Stop, Forward
	45	045	Chase 1	Reverse, Stop, Forward
	46	046	Chase 2	Reverse, Stop, Forward
	47	047	Chase 3	Reverse, Stop, Forward
	48	048	Chase 4	Reverse, Stop, Forward
	49	049	Chase 5	Reverse, Stop, Forward
	50	050	Chase 6	Reverse, Stop, Forward
	51	051	Chase 7	Reverse, Stop, Forward
	52	052	Chase 8	Reverse, Stop, Forward
	53	053	Chase 9	Reverse, Stop, Forward
	54	054	Chase 10	Reverse, Stop, Forward
	55-59	055 - 059	No Function	No Function
60	060	Center Chase	Reverse, Stop, Forward	
61	061	Center Chase 2	Reverse, Stop, Forward	
62-100	062 - 100	No Function	No Function	

CONTINUED ON NEXT PAGE





## RGBW FX TABLE

TYPE	SLOT	DMX VALUES	NAME	FX ADJUSTMENT
Intensity (continued)	<b>REVISED WITH SOFTWARE UPDATE VERSION 1.2.2</b>			
	55	055	Center Chase	Reverse, Stop, Forward
	56	056	Center Chase 2	Reverse, Stop, Forward
	57	057	Alternate	Reverse, Stop, Forward
	58	058	Burst Spark LED	Reverse, Stop, Forward
	59	059	Burst RGBW	Reverse, Stop, Forward
	60	060	Strobe Alternate	Reverse, Stop, Forward
	62	062	Lens/Spark LED Alternate	Reverse, Stop, Forward
	66-100	066 - 100	No Function	No Function
Static Patterns	101	101	Top 2	Disabled
	102	102	Center 3	Disabled
	103	103	Bottom 2	Disabled
	104	104	Top and Bottom	Disabled
	105	105	X	Disabled
	106	106	Ring	Disabled
	107	107	Center Dot	Disabled
	108	108	Slash	Disabled
	109	109	Backslash	Disabled
	110	110	Arrow Left	Disabled
	111	111	Arrow Right	Disabled
	112	112	<	Disabled
	113	113	>	Disabled
		114-255	114 - 255	No Function
Color	<b>REVISED WITH SOFTWARE UPDATE VERSION 1.2.2</b>			
	131	131	RGBW Cells	Reverse, Stop, Forward
	132	132	RGBWCMY Cells	Reverse, Stop, Forward
	133	133	Color Wheel Cells	Reverse, Stop, Forward
	134	134	RGBW Rows	Reverse, Stop, Forward
	135	135	RGBWCMY Rows	Reverse, Stop, Forward
	136	136	Color Wheel Rows	Reverse, Stop, Forward
	137	137	RGBW Columns	Reverse, Stop, Forward
	138	138	RGBWCMY Columns	Reverse, Stop, Forward
	139	139	Color Wheel Columns	Reverse, Stop, Forward
	140	140	RGBW Single Row	Reverse, Stop, Forward
	141	141	RGBWCMY Single Row	Reverse, Stop, Forward
	142	142	Color Wheel Single Row	Reverse, Stop, Forward
CONTINUED ON NEXT PAGE				

## RGBW PIXEL FX TABLE

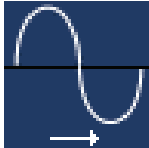
TYPE	SLOT	DMX VALUES	NAME	FX ADJUSTMENT
Color (continued)	<b>REVISED WITH SOFTWARE UPDATE VERSION 1.2.2</b>			
	143	143	RGBW Single Columns	Reverse, Stop, Forward
	144	144	RGBWCMY Single Columns	Reverse, Stop, Forward
	145	145	Color Wheel Single Columns	Reverse, Stop, Forward
	146	146	RGB Rows	Reverse, Stop, Forward
	147	147	RGB Columns	Reverse, Stop, Forward
	148	148	Red White Cells	Reverse, Stop, Forward
	149	149	Green White Cells	Reverse, Stop, Forward
	150	150	Blue White Cells	Reverse, Stop, Forward
	151	151	Red Green Cells	Reverse, Stop, Forward
	152	152	Red Blue Cells	Reverse, Stop, Forward
	153	153	Blue Green Cells	Reverse, Stop, Forward
	154	154	Ring - Center Mix to Color Wheel	Reverse, Stop, Forward
	155	155	Random White Cell	Reverse, Stop, Forward
	156	156	Random White Row	Reverse, Stop, Forward
	157	157	Random White Column	Reverse, Stop, Forward
	158	158	White Flash	Reverse, Stop, Forward
	159	159	Red Flash	Reverse, Stop, Forward
	160	160	Green Flash	Reverse, Stop, Forward
	161	161	Blue Flash	Reverse, Stop, Forward
162	162	Color Wheel Flash	Reverse, Stop, Forward	
163	163	Alternate Color	Reverse, Stop, Forward	
164-255	164 - 255	No Function	No Function	

# SPARK LED FX TABLE

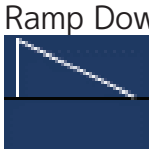
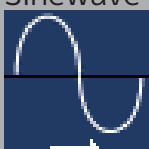
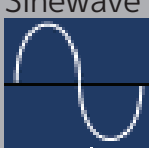
TYPE	SLOT	DMX VALUES	NAME	FX ADJUSTMENT	
Waveform	0	000	Off		
	1	001	Sinewave (default) 		
	2	002	Step 		
	3	003	Sawtooth 		
	4	004	Ramp Up 		
	5	005	Ramp Down 		
	6-10	006 - 010	No Function		
	<b>REVISED WITH SOFTWARE UPDATE VERSION 1.1.1</b>				
		0	000	Off	
		1	001	Sinewave Cross (default) 	
	2	002	Sinewave Full 		

CONTINUED ON NEXT PAGE

# SPARK LED FX TABLE

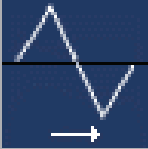
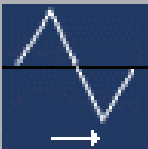
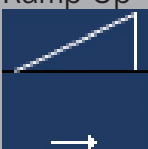
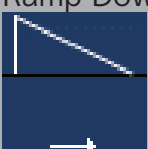
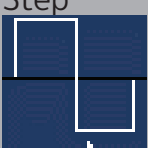
TYPE	SLOT	DMX VALUES	NAME	FX ADJUSTMENT
Waveform (continued)	<b>REVISED WITH SOFTWARE UPDATE VERSION 1.1.1</b>			
	3	003	Sawtooth Cross 	
	4	004	Sawtooth Full 	
	5	005	Ramp Up 	
	6	006	Ramp Down 	
	7	007	Step 	
	8-10	008 - 010	No Function	
Spark LED FX	11	011	Starfield	Reverse, Stop, Forward
	12	012	1 Pixel	Reverse, Stop, Forward
	13	013	2 Pixels	Reverse, Stop, Forward
	14	014	3 Pixels	Reverse, Stop, Forward
	15	015	4 Pixels	Reverse, Stop, Forward
	16	016	5 Pixels	Reverse, Stop, Forward
	17	017	7 Pixels	Reverse, Stop, Forward
	18	018	14 Pixels	Reverse, Stop, Forward
	19	019	Single Row	Reverse, Stop, Forward
	20	020	3 Rows	Reverse, Stop, Forward
	21	021	Single Column	Reverse, Stop, Forward
22	022	3 Columns	Reverse, Stop, Forward	
CONTINUED ON NEXT PAGE				

## SPARK LED FX TABLE

TYPE	SLOT	DMX VALUES	NAME	FX ADJUSTMENT
Spark LED FX (continued)	23	023	Pixel Ring Chase	Reverse, Stop, Forward
	24	024	Pixel Row Chase	Reverse, Stop, Forward
	25	025	Pixel Ring Chase 2	Reverse, Stop, Forward
	26	026	Center Out	Reverse, Stop, Forward
	27	027	Fireworks	Reverse, Stop, Forward
	28	028	Ring	Reverse, Stop, Forward
	29	029	Row	Reverse, Stop, Forward
	30	030	Snake	Reverse, Stop, Forward
	31-90	031 - 090	No Function	No Function
Spark LED Lens Combos	91-100	091 - 100	No Function	No Function
Full Lens Patterns	101	101	Single	Reverse, Stop, Forward
	102	102	Single Bounce	Reverse, Stop, Forward
	103	103	Snake	Reverse, Stop, Forward
	104	104	Snake Bounce	Reverse, Stop, Forward
	105	105	Rows	Reverse, Stop, Forward
	106	106	Rows Bounce	Reverse, Stop, Forward
	107	107	Column	Reverse, Stop, Forward
	108	108	Column Bounce	Reverse, Stop, Forward
	109	109	Columns 2	Reverse, Stop, Forward
	110	110	Slash	Reverse, Stop, Forward
	111	111	Backslash	Reverse, Stop, Forward
	112	112	Slash Back	Reverse, Stop, Forward
	113	113	<>	Reverse, Stop, Forward
	114	114	><	Reverse, Stop, Forward
	115	115	>>	Reverse, Stop, Forward
	116	116	<<	Reverse, Stop, Forward
	117	117	Rotating Bar	Reverse, Stop, Forward
	118	118	Rotating Dot	Reverse, Stop, Forward
	119	119	Rotating 2 Dot	Reverse, Stop, Forward
	120	120	Ring 2 Cell	Reverse, Stop, Forward
	121	121	Ring 2 Cell Overlap	Reverse, Stop, Forward
	122	122	Ring 3 Cell Blend	Reverse, Stop, Forward
	123	123	Ring - Center Fade	Reverse, Stop, Forward
	124	124	X-Bar	Reverse, Stop, Forward
	125	125	Diagonals	Reverse, Stop, Forward
	126	126	Arrow Left	Reverse, Stop, Forward
CONTINUED ON NEXT PAGE				

## SPARK LED FX TABLE

TYPE	SLOT	DMX VALUES	NAME	FX ADJUSTMENT
<b>Full Lens Patterns (continued)</b>	127	127	Arrow Right	Reverse, Stop, Forward
	128	128	2 Pixels	Reverse, Stop, Forward
	129	129	3 Pixels	Reverse, Stop, Forward
	130	130	4 Pixels	Reverse, Stop, Forward
	131	131	1, 2, 3, 4 Pixels	Reverse, Stop, Forward
	132	132	Ring Build	Reverse, Stop, Forward
	133	133	Ring Build Erase	Reverse, Stop, Forward
	134	134	Ring Build Erase 2	Reverse, Stop, Forward
	135	135	Chase 1	Reverse, Stop, Forward
	136	136	Chase 2	Reverse, Stop, Forward
	137	137	Chase 3	Reverse, Stop, Forward
	138	138	Chase 4	Reverse, Stop, Forward
	139	139	Chase 5	Reverse, Stop, Forward
	140	140	Chase 6	Reverse, Stop, Forward
	141	141	Chase 7	Reverse, Stop, Forward
	142	142	Chase 8	Reverse, Stop, Forward
	143	143	Chase 9	Reverse, Stop, Forward
	144	144	Chase 10	Reverse, Stop, Forward
	145	145	Center Chase	Reverse, Stop, Forward
	146	146	Center Chase 2	Reverse, Stop, Forward
	147-200	147 - 200	No Function	No Function
<b>Full Lens Static Patterns</b>	201	201	Top 2	Disabled
	202	202	Center 3	Disabled
	203	203	Bottom 2	Disabled
	204	204	Top and Bottom	Disabled
	205	205	X	Disabled
	206	206	Ring	Disabled
	207	207	Center Dot	Disabled
	208	208	Slash	Disabled
	209	209	Backslash	Disabled
	210	210	Arrow Left	Disabled
	211	211	Arrow Right	Disabled
	212	212	<	Disabled
	213	213	>	Disabled
		214-255	214 - 255	No Function

CONTINUED ON NEXT PAGE

## SPARK LED FX TABLE

TYPE	SLOT	DMX VALUES	NAME	FX ADJUSTMENT
Spark LED Pattern	226	226	Row 1	Disabled
	227	227	Row 2	Disabled
	228	228	Row 3	Disabled
	229	229	Row 4	Disabled
	230	230	Row 5	Disabled
	231	231	Row 6	Disabled
	232	232	Row 7	Disabled
	233	233	Column 1	Disabled
	234	234	Column 2	Disabled
	235	235	Column 3	Disabled
	236	236	Column 4	Disabled
	237	237	Column 5	Disabled
	238	238	Column 6	Disabled
	239	239	Column 7	Disabled
	240	240	Ring 1	Disabled
	241	241	Ring 2	Disabled
	242	242	Ring 3	Disabled
	243-255	243 - 255	No Function	No Function

## ERROR CODES

When power is applied, the unit will automatically enter a "Reset/Test" mode, which brings all the internal motors to a home position. If there is an internal problem with one or more of the motors, an error code will flash on the display screen. For example, when the display shows "Pan Er" it means there is some type of error with the Pan motor. If there are multiple errors during the start-up process they will all flash in the display. For example: if the fixture has Pan, Tilt, and Zoom errors all at the same time, you will see the error message "Pan Er", "Tilt Er", and "Zoom Er" flash in sequence 5 times.

If an error occurs during the initial start-up procedure, the fixture will self-generate a second reset signal and try to realign all the motors and correct the errors. If the error persists after a second attempt, a third attempt will be made. If after a third attempt all the errors have not been corrected, the fixture will make the following determinations:

- **3 or More Errors** - The fixture cannot function properly with three or more errors, and therefore the fixture will place itself in stand-by mode until subsequent repairs can be made.
- **Less Than 3 Errors** - The fixture has less than 3 errors, and therefore most other functions will work properly. The fixture will attempt to operate normally until the errors can be corrected by a technician. The errors in question will remain flashing in the display as a reminder of internal errors.

Note: Error Codes are subject to change without any prior written notice.	
ERROR CODES	DESCRIPTION
Pan Er	Movement is not located in the default position after the reset. This message will appear after a fixture reset if the magnetic-indexing circuit malfunctions (sensor failed, or magnet is missing) or there is a motor failure (defective motor or a defective motor IC drive on the main PCB). This error may also be displayed if the head/yoke was blocked during a reset function.
Tilt Er	
Zoom Er	Movement is not located in the default position after the reset. This message will appear after a fixture reset if the magnetic-indexing circuit malfunctions (sensor failed, or magnet is missing) or there is a motor failure (defective motor or a defective motor IC drive on the main PCB).

# SPECIFICATIONS

## SOURCE

(7) 60W Osram RGBW LEDs

(28) 2W White SparkLED™

50,000 Hour Average LED Life\*

\*Test lab conditions. May vary depending on several factors including but not limited to:  
Environmental Conditions, Power/Voltage, Usage Patterns (On-Off Cycling), Control, and Dimming.

## PHOTOMETRIC DATA

7,200 Total Lumen Output

CRI 80

Zoom Range 5° - 77°

Beam Angle 5.4° - 56.4°

Field Angle 8.1° - 74°

## EFFECTS

Motorized Zoom

Linear Color Temperature Presets (2700-8000K)

RGBW Color Mixing and Pixel Control

White SparkLED Lens Effect

Color Presets and Macros

Electronic Strobe and Variable Dimming Curves

16-bit Dimming

Pan Angle: 540°/630°

Tilt Angle: 270°/360°

## CONTROL / CONNECTIONS

3 DMX Channel Modes (25 / 52 / 80 channels)

360° Continuous Pan and Tilt Movement

DMX Adjustable Refresh Rate (900 -25000 Hz)

(6) Button Touch Panel

Full Color 180° Reversible LCD Menu Display

RDM Support

IP65 5pin XLR DMX In/Out

IP65 RJ45 Ethernet In/Out (Art-Net, sACN)

IP65 Locking Power Cable In

With Wired Digital Communication Network

## SIZE / WEIGHT

Length: 14.31 in (363.4mm)

Width: 10.24 in (259.97mm)

Height: 19.43 in (493.44mm)

Weight: 41.0 lbs. (18.6kg)

## ELECTRICAL / THERMAL

AC 100-240V 50/60Hz

700W Max Power Consumption

BTU/hr (+/- 10%) 2387

## APPROVALS / RATINGS

CE | cETLus | IP65



# DIMENSIONAL DRAWINGS

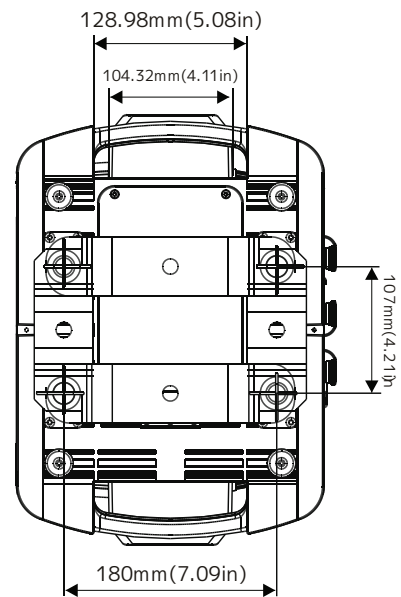
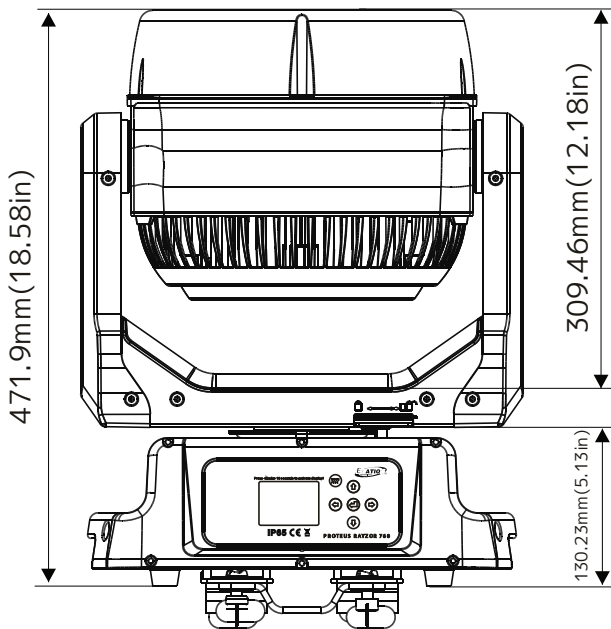
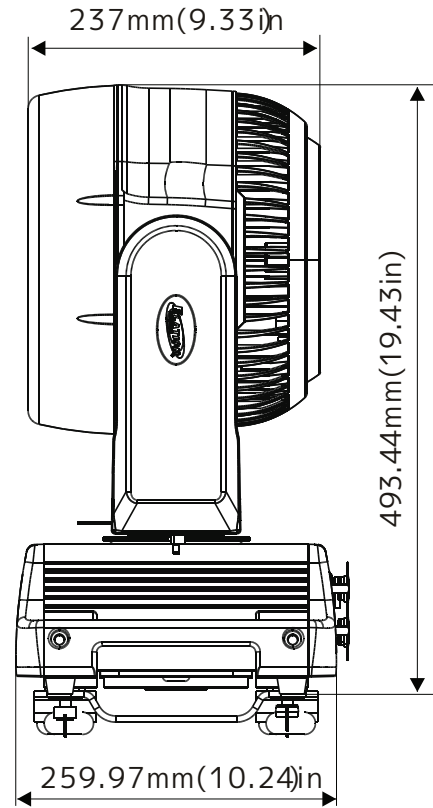
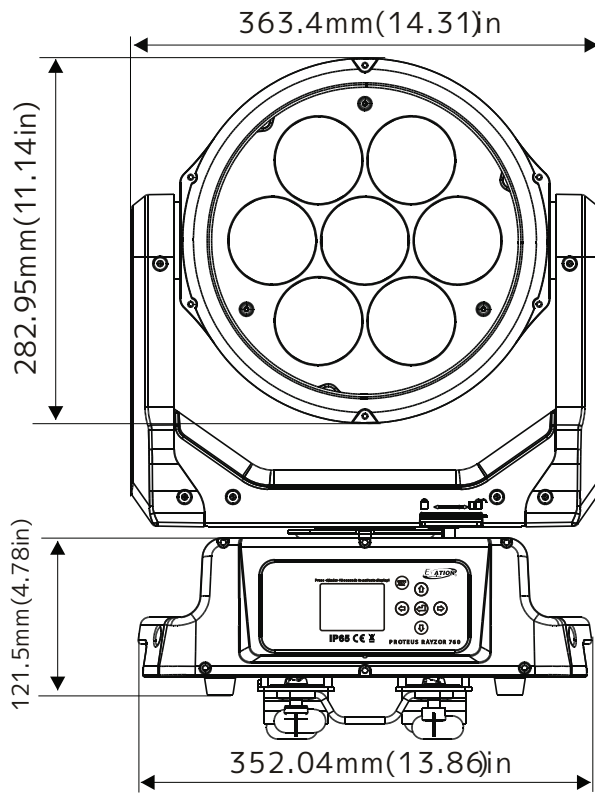

Specifications and improvements in the design of this unit and this manual are subject to change without notice.

## OPTIONAL ACCESSORIES

ORDER CODE	ITEM
IP TESTER	IP Fixture Vacuum and Pressure Leak Tester
TRIGGER CAMP	Heavy Duty Wrap Around Hook Style Clamp
STR527	5 ft (1.5m) IP65 5-pin XLR Cable (additional cable lengths are available)

## FCC STATEMENT

This device complies with Part 15 of the FCC Rules. Operation is subject to the following two conditions: (1) this device may not cause harmful interference, and (2) this device must accept any interference received, including interference that may cause undesired operation.

## FCC RADIO FREQUENCY INTERFERENCE WARNINGS & INSTRUCTIONS

This product has been tested and found to comply with the limits as per Part 15 of the FCC Rules. These limits are designed to provide reasonable protection against harmful interference in a residential installation. This device uses and can radiate radio frequency energy and, if not installed and used in accordance with the included instructions, may cause harmful interference to radio communications. However, there is no guarantee that interference will not occur in a particular installation. If this device does cause harmful interference to radio or television reception, which can be determined by turning the device off and on, the user is encouraged to try to correct the interference by one or more of the following methods:

- Reorient or relocate the device.
- Increase the separation between the device and the receiver.
- Connect the device and the radio receiver to electrical outlets on two different circuits.
- Consult the dealer or an experienced radio/TV technician for help.



## Europe Energy Saving Notice

Energy Saving Matters (EuP 2009/125/EC)

Saving electric energy is a key to help protecting the environment. Please turn off all electrical products when they are not in use. To avoid power consumption in idle mode, disconnect all electrical equipment from power when not in use. Thank you.

