



# **ARTISTE PICASSO™**

user manual

©2022 ELATION PROFESSIONAL all rights reserved. Information, specifications, diagrams, images, and instructions herein are subject to change without notice. ELATION PROFESSIONAL logo and identifying product names and numbers herein are trademarks of ELATION PROFESSIONAL. Copyright protection claimed includes all forms and matters of copyrightable materials and information now allowed by statutory or judicial law or hereinafter granted. Product names used in this document may be trademarks or registered trademarks of their respective companies and are hereby acknowledged. All non-ELATION brands and product names are trademarks or registered trademarks of their respective companies.

**ELATION PROFESSIONAL** and all affiliated companies hereby disclaim all liabilities for property, equipment, building, and electrical damages, injuries to any persons, and direct or indirect economic loss associated with the use or reliance of any information contained within this document, and/or because of the improper, unsafe, insufficient, and negligent assembly, installation, rigging, and operation of this product.

**Elation Professional USA** | 6122 S. Eastern Ave. | Los Angeles, CA. 90040  
323-582-3322 | 323-832-9142 fax | [www.elationlighting.com](http://www.elationlighting.com) | [info@elationlighting.com](mailto:info@elationlighting.com)

**Elation Professional B.V.** | Junostraat 2 | 6468 EW Kerkrade, The Netherlands  
+31 45 546 85 66 | +31 45 546 85 96 fax | [www.elationlighting.eu](http://www.elationlighting.eu) | [info@elationlighting.eu](mailto:info@elationlighting.eu)

**Elation Professional Mexico** | AV Santa Ana 30 | Parque Industrial Lerma, Lerma, Mexico 52000  
+52 (728) 282-7070



## DOCUMENT VERSION

Due to additional product features and/or enhancements, an updated version of this document may be available online. Please check [www.elationlighting.com](http://www.elationlighting.com) for the latest revision/update of this manual, before beginning installation and/or programming.

Date	Document Version	Software Version ≥	DMX Channel Modes	Notes
05/03/18	1.0	1.1.0	36 / 62	Initial release.
05/08/18	1.2	1.1.2	NO CHANGE	Added Refresh Rate values to DMX control.
05/09/18	1.4	N/C	NO CHANGE	Added USB software update instructions.
05/15/18	1.6	N/C	NO CHANGE	Updated max power consumption to 1000W.
10/05/18	1.8	1.1.4	See DMX Chart	Updated Frost Channel DMX values.
12/05/18	2.0	N/C	NO CHANGE	Updated release.
07/17/19	2.1	1.1.5	NO CHANGE	Updated Select Signal System Menu.
06/22/20	2.2	N/C	NO CHANGE	Updated thermal, box contents and QR Code
08/21/20	2.4	N/C	NO CHANGE	Updated framing index
10/06/20	2.6	N/C	NO CHANGE	Updated specifications
02/23/21	2.8	1.1.7	NO CHANGE	Updated Software
03/16/21	3.0	N/C	NO CHANGE	Updated sun protection & FCC Statement
06/03/21	3.2	N/C	NO CHANGE	Updated DMX Channels & Functions
07/07/21	3.4	N/C	NO CHANGE	Added FIL dimension drawing
04/20/22	3.6	N/C	NO CHANGE	Updated General Information, added RDM
10/13/22	3.8	N/C	NO CHANGE	Updated Installation Guidelines, RDM, System Menu, Specification, Dimensional Drawings; added Handling Guidelines, Fan Modes

# CONTENTS

General Information	4
Limited Warranty (USA Only)	5
Safety Guidelines	6
Maintenance Guidelines	8
Handling Guidelines	9
Fixture Overview	10
Colors and Gobos	11
Custom Gobos	12
Installation Guidelines	13
Remote Device Management (RDM)	17
System Menu	18
Fan Modes	27
E-FLY Wireless DMX Set Up	28
E-FLY Wireless Installation Location Guidelines	29
DMX Channel Functions And Values	30
Error Codes	41
Specifications	43
Dimensional Drawings	44
Optional Accessories   FCC Statement	46

# GENERAL INFORMATION

## INTRODUCTION

Please read and understand the instructions in this manual carefully and thoroughly before attempting to operate this device. These instructions contain important safety and use information. ***This device is intended for use by professionally trained personnel only, and is not suitable for private use.***

## UNPACKING

Every device has been thoroughly tested and has been shipped in perfect operating condition. Carefully check the shipping carton for damage that may have occurred during shipping. If the carton is damaged, carefully inspect the device for damage, and be sure all accessories necessary to install and operate the device have arrived intact. In the event damage has been found or parts are missing, please contact our customer support team for further instructions. Please do not return this device to your dealer without first contacting customer support. Please do not discard the shipping carton in the trash. Please recycle whenever possible.

## BOX CONTENTS

Power Cable  
Omega Brackets (x2)

## CUSTOMER SUPPORT

Contact ELATION Service for any product related service and support needs. Also visit [forums.elationlighting.com](https://forums.elationlighting.com) with questions, comments, or suggestions.

**ELATION SERVICE USA - Monday - Friday 8:00am to 4:30pm PST**  
323-582-3322 | Fax 323-832-9142 | [support@elationlighting.com](mailto:support@elationlighting.com)

**ELATION SERVICE EUROPE - Monday - Friday 08:30 to 17:00 CET**  
+31 45 546 85 63 | Fax +31 45 546 85 96 | [support@elationlighting.eu](mailto:support@elationlighting.eu)

**REPLACEMENT PARTS** please visit [parts.elationlighting.com](https://parts.elationlighting.com)



## I M P O R T A N T N O T I C E !

**THERE ARE NO USER SERVICEABLE PARTS INSIDE THIS UNIT. DO NOT ATTEMPT ANY REPAIRS YOURSELF; DOING SO WILL VOID YOUR MANUFACTURES WARRANTY. DAMAGES RESULTING FROM MODIFICATIONS TO THIS FIXTURE AND/OR THE DISREGARD OF SAFETY INSTRUCTIONS AND GUIDELINES IN THIS MANUAL VOID THE MANUFACTURES WARRANTY AND ARE NOT SUBJECT TO ANY WARRANTY CLAIMS AND/OR REPAIRS.**

## LIMITED WARRANTY (USA ONLY)

- A. Elation Professional hereby warrants, to the original purchaser, Elation Professional products to be free of manufacturing defects in material and workmanship for a period of two years (730 days), and Elation Professional product rechargeable batteries to be free of manufacturing defects in material and workmanship for a period of six months (180 days), from the original date of purchase. This warranty excludes discharge lamps and all product accessories. This warranty shall be valid only if the product is purchased within the United States of America, including possessions and territories. It is the owner's responsibility to establish the date and place of purchase by acceptable evidence, at the time service is sought.
- B. For warranty service, send the product only to the Elation Professional factory. All shipping charges must be pre-paid. If the requested repairs or service (including parts replacement) are within the terms of this warranty, Elation Professional will pay return shipping charges only to a designated point within the United States. If any product is sent, it must be shipped in its original package and packaging material. No accessories should be shipped with the product. If any accessories are shipped with the product, Elation Professional shall have no liability whatsoever for loss and/or or damage to any such accessories, nor for the safe return thereof.
- C. This warranty is void if the product serial number and/or labels are altered or removed; if the product is modified in any manner which Elation Professional concludes, after inspection, affects the reliability of the product; if the product has been repaired or serviced by anyone other than the Elation Professional factory unless prior written authorization was issued to purchaser by Elation Professional; if the product is damaged because not properly maintained as set forth in the product instructions, guidelines and/or user manual.
- D. This is not a service contract, and this warranty does not include any maintenance, cleaning, or periodic check-up. During the periods as specified above, Elation Professional will replace defective parts at its expense, and will absorb all expenses for warranty service and repair labor by reason of defects in material or workmanship. The sole responsibility of Elation Professional under this warranty shall be limited to the repair of the product, or replacement thereof, including parts, at the sole discretion of Elation Professional. All products covered by this warranty were manufactured after January 1, 1990, and bare identifying marks to that effect.
- E. Elation Professional reserves the right to make changes in design and/or performance improvements upon its products without any obligation to include these changes in any products theretofore manufactured.
- F. No warranty, whether expressed or implied, is given or made with respect to any accessory supplied with the products described above. Except to the extent prohibited by applicable law, all implied warranties made by Elation Professional in connection with this product, including warranties of merchantability or fitness, are limited in duration to the warranty periods set forth above. And no warranties, whether expressed or implied, including warranties of merchantability or fitness, shall apply to this product after said periods have expired. The consumer's and/or dealer's sole remedy shall be such repair or replacement as is expressly provided above; and under no circumstances shall Elation Professional be liable for any loss and/or damage, direct and/or consequential, arising out of the use of, and/or the inability to use, this product.
- G. This warranty is the only written warranty applicable to Elation Professional products and supersedes all prior warranties and written descriptions of warranty terms and conditions heretofore published.

### WARRANTY RETURNS

All returned service items whether under warranty or not, must be freight pre-paid and accompany a return authorization (R.A.) number. The R.A. number must be clearly written on the outside of the return package. A brief description of the problem as well as the R.A. number must also be written down on a piece of paper and included in the shipping container. If the unit is under warranty, you must provide a copy of your proof of purchase invoice. Items returned without a R.A. number clearly marked on the outside of the package will be refused and returned at customer's expense. You may obtain a R.A. number by contacting customer support. **ONLY** Use the original packaging and materials to transport the fixture in for service.

# SAFETY GUIDELINES

This fixture is an extremely sophisticated piece of electronic equipment. To guarantee a smooth operation, it is important to follow all instructions and guidelines in this manual. The manufacturer of this device is not responsible for injury and/or damages resulting from the misuse of this fixture due to the disregard of the information printed in this manual. Only qualified and/or certified personnel should perform installation of this fixture and only the original rigging parts (omega brackets) included with this fixture should be used for installation. Any modifications to the fixture and/or the mounting hardware included will void the original manufactures warranty and increase the risk of damage and/or personal injury.



## **PROTECTION CLASS 1 - FIXTURE MUST BE PROPERLY GROUNDED**

**THERE ARE NO USER SERVICEABLE PARTS INSIDE THIS UNIT.  
DO NOT ATTEMPT ANY REPAIRS YOURSELF; DOING SO WILL VOID YOUR MANUFACTURES WARRANTY. DAMAGES RESULTING FROM MODIFICATIONS TO THIS FIXTURE AND/OR THE DISREGARD OF SAFETY INSTRUCTIONS AND GUIDELINES IN THIS MANUAL VOID THE MANUFACTURES WARRANTY AND ARE NOT SUBJECT TO ANY WARRANTY CLAIMS AND/OR REPAIRS.**



**DO NOT PLUG FIXTURE INTO A DIMMER PACK!  
NEVER OPEN THIS FIXTURE WHILE IN USE!  
UNPLUG POWER BEFORE SERVICING FIXTURE!  
NEVER TOUCH FIXTURE DURING OPERATION, AS IT MAY BE HOT!  
KEEP FLAMMABLE MATERIALS AWAY FROM FIXTURE!**



**NEVER LOOK DIRECTLY INTO THE LIGHT SOURCE!  
RETINA INJURY RISK - MAY INDUCE BLINDNESS!  
SENSITIVE PERSONS MAY SUFFER AN EPILEPTIC SHOCK!**



**INDOOR / DRY LOCATIONS USE ONLY!  
DO NOT EXPOSE FIXTURE TO RAIN AND MOISTURE!**



**MINIMUM DISTANCE TO OBJECTS/SURFACES  
MUST BE 6.6 FEET (2.0 METERS)  
MAXIMUM TEMPERATURE OF EXTERNAL SURFACE  
185° F (85°C)**

# SAFETY GUIDELINES

**DO NOT TOUCH** the fixture housing during operation. Turn OFF the power and allow approximately 15 minutes for the fixture to cool down before serving.

**DO NOT** shake fixture, avoid brute force when installing and/or operating fixture.

**DO NOT** operate fixture if the power cord is frayed, crimped, damaged and/or if any of the power cord connectors are damaged and do not insert into the fixture securely with ease. **NEVER** force a power cord connector into the fixture. If the power cord or any of its connectors are damaged, replace it immediately with a new one of similar power rating.

**DO NOT** block any air ventilation slots.

All fan and air inlets must remain clean and never blocked.

Allow approx. 6" (15cm) between fixture and other devices or a wall for proper cooling.

When installing fixture in a suspended environment, always use mounting hardware that is no less than M10 x 25 mm, and always install fixture with an appropriately rated safety cable.

Always disconnect fixture from main power source before performing any type of service and/or cleaning procedure. Only handle the power cord by the plug end, never pull out the plug by tugging the wire portion of the cord.

During the initial operation of this fixture, a light smoke or smell may emit from the interior of the fixture. This is a normal process and is caused by excess paint in the interior of the casing burning off from the heat associated with the lamp and will decrease gradually over time.

Consistent operational breaks will ensure fixture will function properly for many years.

# MAINTENANCE GUIDELINES



**DISCONNECT POWER BEFORE PERFORMING ANY MAINTENANCE!**

## CLEANING

Frequent cleaning is recommended to insure proper function, optimized light output, and an extended life. The frequency of cleaning depends on the environment in which the fixture operates: damp, smoky or particularly dirty environments can cause greater accumulation of dirt on the fixture's optics. Clean the external lens surface at least every 20 days with a soft cloth to avoid dirt/debris accumulation.

**NEVER** use alcohol, solvents, or ammonia-based cleaners.

## MAINTENANCE

Regular inspections are recommended to insure proper function and extended life.

There are no user serviceable parts inside this fixture, please refer all other service issues to an authorized Elation service technician. Should you need any spare parts, please order genuine parts from your local Elation dealer.

Please refer to the following points during routine inspections:

A detailed electric check by an approved electrical engineer every three months, to make sure the circuit contacts are in good condition and prevent overheating.

Be sure all screws and fasteners are securely tightened at all times. Loose screws may fall out during normal operation resulting in damage or injury as larger parts could fall.

Check for any deformations on the housing, color lenses, rigging hardware and rigging points (ceiling, suspension, trussing). Deformations in the housing could allow for dust to enter into the fixture. Damaged rigging points or unsecured rigging could cause the fixture to fall and seriously injure a person(s).

Electric power supply cables must not show any damage, material fatigue or sediments. **NEVER** remove the ground prong from the power cable.



# HANDLING GUIDELINES

The device is a large format fixture that contains delicate optics and glass filters. While this product was carefully designed to be roadworthy, it must be handled carefully during transportation. Before transport, ensure that the color flags inside the unit are placed in an OPEN position. For superior impact protection, the fixture is shipped in a custom fitted high-density Foam Inlay (FIL). This FIL must be used inside the road-cases for transportation.

**DO NOT TIP THE CASE OVER, AND AVOID ALL SHOCKS AND ROUGH HANDLING, ESPECIALLY “TIPPING”, THE PRACTICE OF TIPPING THE FIXTURE-CASE OVER TO ITS SIDE AND ONTO A HARD SURFACE. THE CASE MUST RIDE ON ITS WHEELS SO THAT THE FIXTURE-HEAD REMAINS HORIZONTAL DURING TRANSPORTATION.**

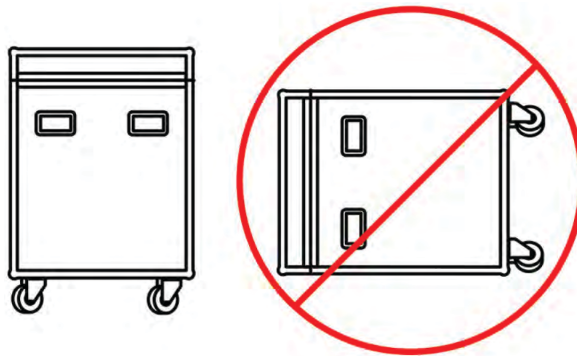

# FIXTURE OVERVIEW

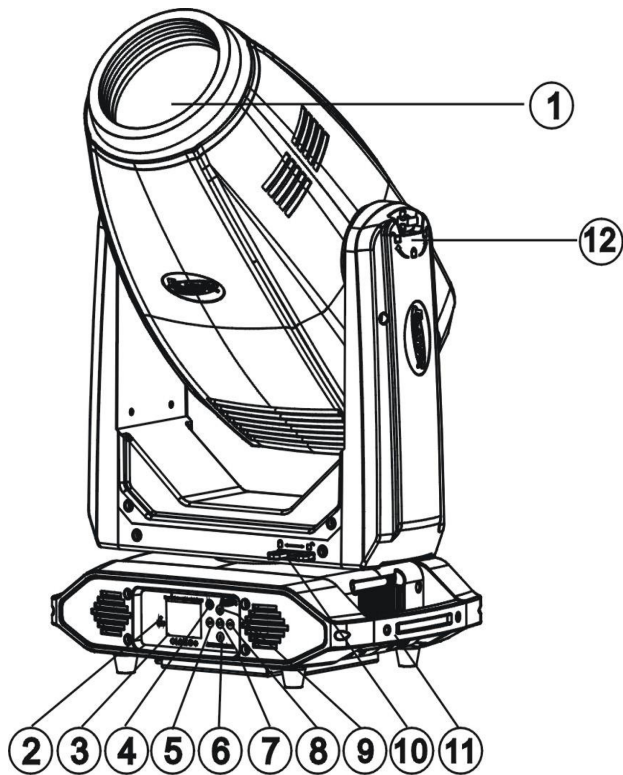

1. LED Lens Array
2. Wireless Indicator
3. LCD Control Menu Display
4. MODE/ESC Button
5. LEFT Button
6. DOWN Button
7. ENTER Button
8. RIGHT Button
9. UP Button
10. PAN Lock
11. Handel (s)
12. TILT Lock
13. RJ45 Ethernet IN
14. RJ45 Ethernet OUT
15. 5pin DMX IN
16. 5pin DMX OUT
17. Fuse
18. Power IN
19. Service Port

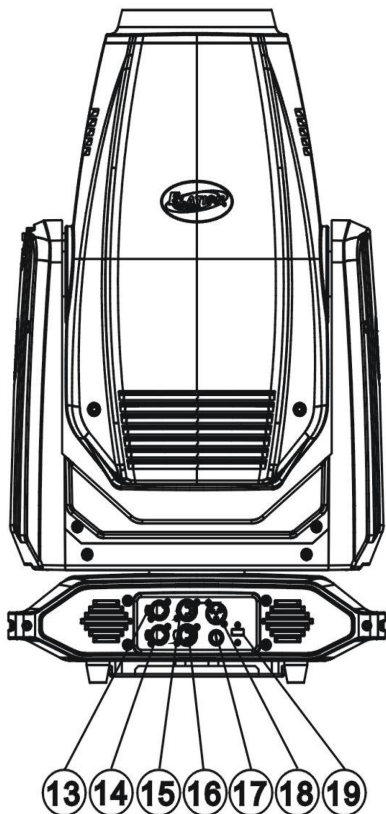

# COLORS AND GOBOS

## COLOR FLAGS

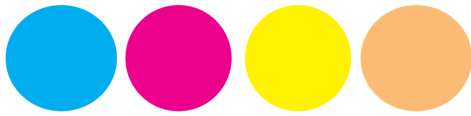

CYAN MAGENTA YELLOW C.T.O.

## COLOR WHEEL



RED Pos. 1 GREEN Pos. 2 HIGH CRI Pos. 3 ORANGE Pos. 4 HALF MINUS GREEN Pos. 5 BLUE Pos. 6

## INTERCHANGEABLE-ROTATING GLASS GOBO WHEEL 1

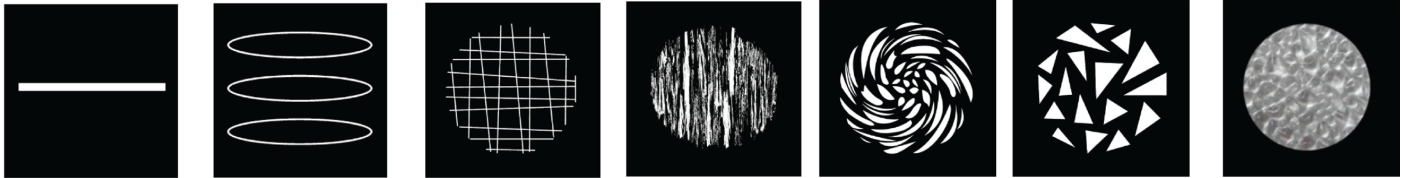

Pos. 1 Pos. 2 Pos. 3 Pos. 4 Pos. 5 Pos. 6 Pos. 7

## INTERCHANGEABLE STATIC-FIXED METAL GOBO WHEEL 2



Pos. 1 Pos. 2 Pos. 3 Pos. 4 Pos. 5 Pos. 6 Pos. 7

# CUSTOM GOBOS

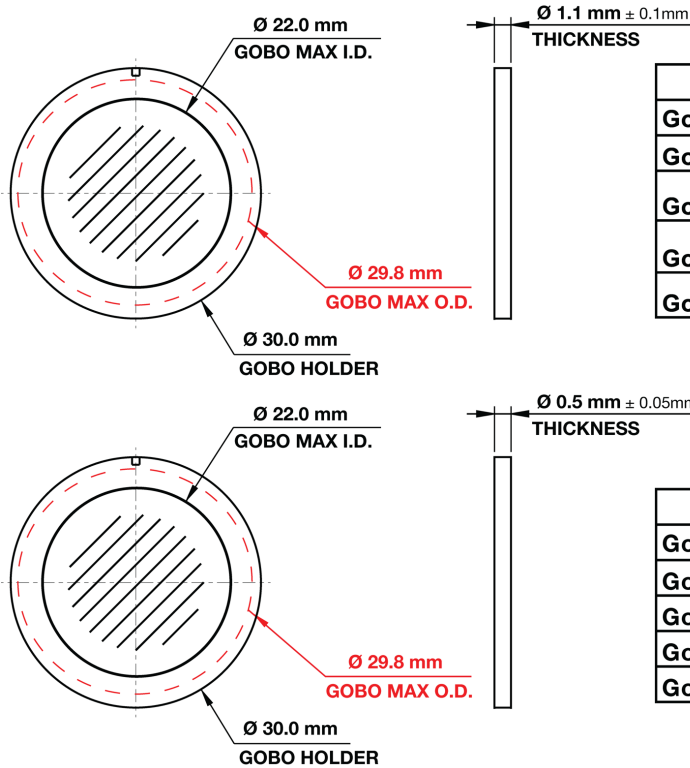

ROTATING GLASS GOBOS - WHEEL 1	
Gobo O.D. (Max. Outer Diameter)	$\varnothing 29.8 \text{ mm}$
Gobo I.D. (Max. Image Diameter)	$\varnothing 22 \text{ mm}$
Gobo Holder Diameter	$\varnothing 30 \text{ mm}$
Gobo Thickness	$1.1 \text{ mm} \pm 0.1 \text{ mm}$
Gobo Material	BOROFLOAT

STATIC-FIXED METAL GOBOS - WHEEL 2	
Gobo O.D. (Max. Outer Diameter)	$\varnothing 29.8 \text{ mm}$
Gobo I.D. (Max. Image Diameter)	$\varnothing 22 \text{ mm}$
Gobo Holder Diameter	$\varnothing 30 \text{ mm}$
Gobo thickness	$0.5 \text{ mm} \pm 0.05 \text{ mm}$
Gobo material	ALUMINUM

**\* \* \* IMPORTANT NOTICE REGARDING CUSTOM GOBOS \* \* \***

Due to the high temperature optical system, special material as listed above is required for custom gobos. Due to varying manufacturing processes and tolerances, it is highly recommended to provide a gobo sample and holder from the fixture to the custom gobo vendor for accurate sizing. Extended testing of custom gobo designs is highly recommended prior to use. Contact ELATION SERVICE for further information.

**ELATION SERVICE USA - Monday - Friday 8:00am to 4:30pm PST**

323-582-3322 | Fax 323-832-9142 | [support@elationlighting.com](mailto:support@elationlighting.com)

**ELATION SERVICE EUROPE - Monday - Friday 08:30 to 17:00 CET**

+31 45 546 85 63 | Fax +31 45 546 85 96 | [support@elationlighting.eu](mailto:support@elationlighting.eu)

# INSTALLATION GUIDELINES

## WARNING

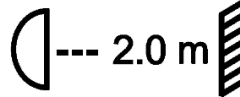

Minimum distance to lighted objects 2.0 meters.  
Maximum temperature of the external surface 85 °C.  
Minimum distance of inflammable materials from the surface 0.5m.



### FLAMMABLE MATERIAL WARNING

Keep fixture minimum 5.0 feet (1.5m) away from flammable materials and/or pyrotechnics.



### ELECTRICAL CONNECTIONS

A qualified electrician should be used for all electrical connections and/or installations.



**USE CAUTION WHEN POWER LINKING OTHER MODEL FIXTURES AS THE POWER CONSUMPTION OF OTHER MODEL FIXTURES MAY EXCEED THE MAX POWER OUTPUT ON THIS FIXTURE. CHECK SILK SCREEN FOR MAX AMPS.**



**DO NOT INSTALL THE FIXTURE IF YOU ARE NOT QUALIFIED TO DO SO!**

Fixture **MUST** be installed following all local, national, and country commercial electrical and construction codes and regulations.

Before rigging/mounting the fixture to any metal truss/structure or placing the fixture on any surface, a professional equipment installer **MUST** be consulted to determine if the metal truss/structure or surface is properly certified to safely hold the combined weight of the fixture, clamps, cables, and accessories.

Fixture ambient operating temperature range is **14° to 113°F. (-10° to 45°C)**

Do not use the fixture under or above this temperature.

Fixture should be installed in areas outside walking paths, seating areas, or away from areas where unauthorized personnel might reach the fixture by hand.

**NEVER** stand directly below the fixture when rigging, removing, or servicing.

Overhead fixture installation must always be secured with a secondary safety attachment, such as an appropriately rated safety cable.

Allow approximately 15 minutes for the fixture to cool down before serving.

# INSTALLATION GUIDELINES

## OMEGA BRACKETS INSTALLATION

Insert the Omega Brackets into the matching holes on the bottom of the fixture. Secure the Omega Brackets to the fixture by turning each quick-lock fastener ¼ turn clockwise; making sure the fastener is completely locked.

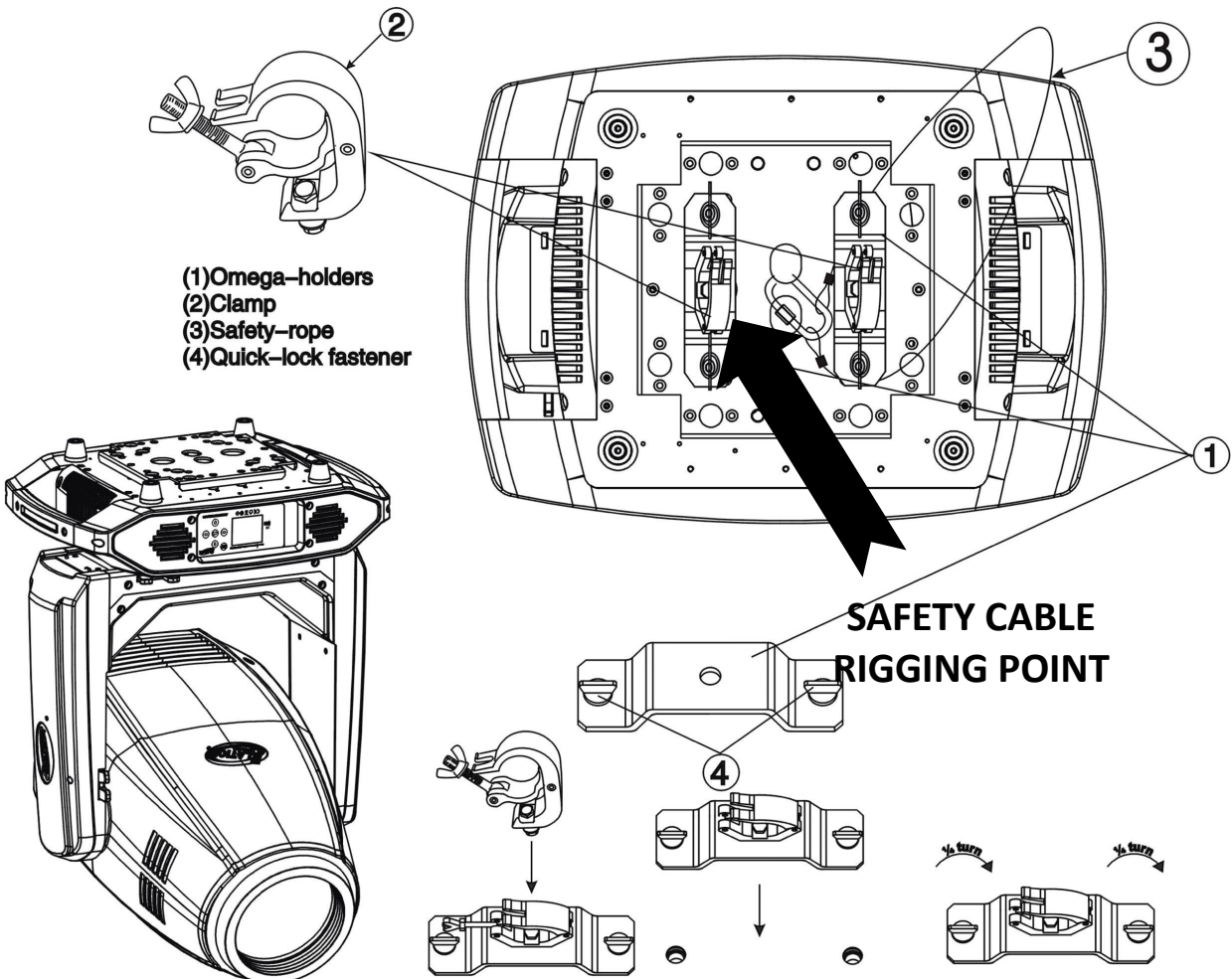

## CLAMP INSTALLATION

When mounting fixture to truss, be sure to secure an appropriately rated professional grade rigging clamp to the included **Omega Brackets** using an M10 screw fitted through the center hole of the **Omega Brackets**. The fixture provides a built-in rigging point for a **SAFETY CABLE**. Be sure to only use the designated rigging point for the safety cable and never secure a safety cable to a carrying handle.

# INSTALLATION GUIDELINES

## RIGGING

Overhead rigging requires extensive experience, including amongst others calculating working load limits, installation material being used, and periodic safety inspection of all installation material and the fixture. If you lack these qualifications, do not attempt the installation yourself. Improper installation can result in bodily injury.

Fixture is fully operational in the specific mounting positions illustrated below.

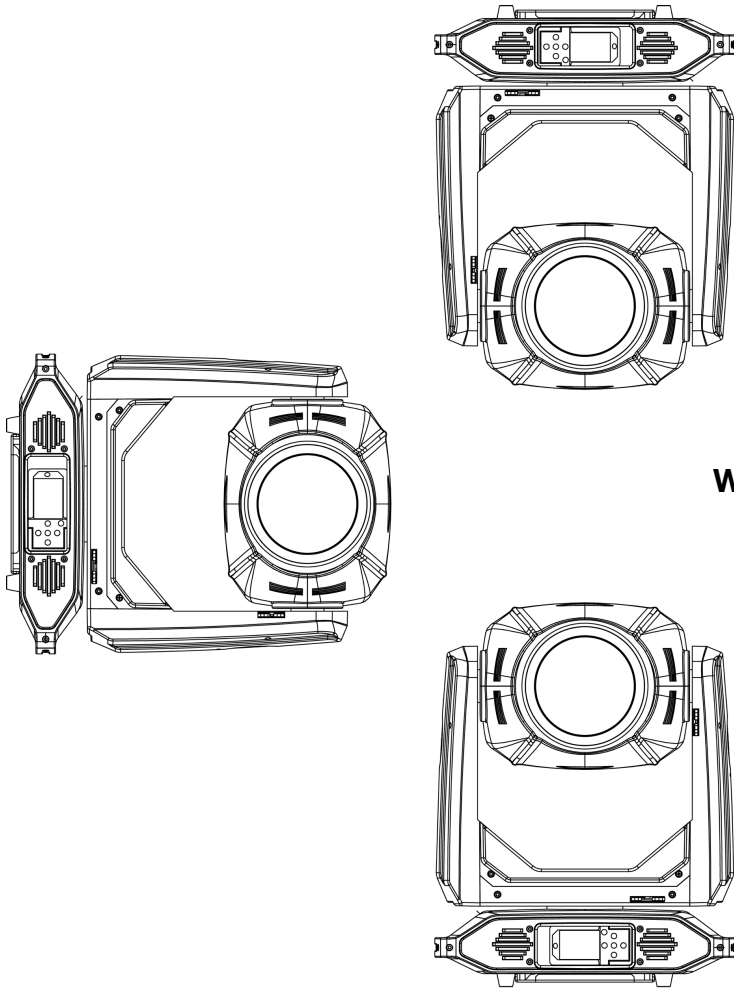

**SAFETY CABLE**  
**ALWAYS ATTACH A SAFETY CABLE**  
**WHENEVER INSTALLING THIS FIXTURE**  
**IN A SUSPENDED ENVIRONMENT TO**  
**ENSURE THE FIXTURE WILL NOT**  
**DROP IF THE CLAMP FAILS.**

## ART-NET CONNECTION

When connecting fixture to a network switch to control multiple devices, a **Gigabit Ethernet Switch** that supports **IGMP (Internet Group Management Protocol)** is required. Using a **Gigabit Ethernet Switch** that does not support **IGMP** can cause erratic behavior of all connected devices to the switch. IGMP: [https://en.wikipedia.org/wiki/Internet\\_Group\\_Management\\_Protocol](https://en.wikipedia.org/wiki/Internet_Group_Management_Protocol)

# INSTALLATION GUIDELINES

## POTENTIAL INTERNAL FIXTURE DAMAGE FROM EXTERNAL SOURCES OF LIGHT BEAMS

External sources of light beams from direct sunlight, lighting moving head fixtures, and lasers, which are focused directly on the exterior housing and/or penetrate the front lens opening of ELATION lighting fixtures, can cause severe internal damage including burning to optics, dichroic color filters, glass and metal gobos, prisms, animation wheels, frost filters, iris, shutters, motors, belts, wiring, discharge lamps, and LEDs.

This issue is not specific only to ELATION lighting fixtures, it is a common issue with lighting fixtures from all manufacturers. Although there is no true way to fully prevent this issue from happening, the guidelines below can prevent any potential damage from occurring if followed. Contact ELATION Service for more details.

**DO NOT EXPOSE THE FIXTURE AND/OR FRONT LENS OPENING TO LIGHT BEAMS FROM DIRECT SUNLIGHT, OTHER LIGHTING MOVING HEAD FIXTURES, AND LASERS WHILE UNPACKING, INSTALLATION, USE, AND EXTENDED IDLE TIMES OUTDOORS. DO NOT FOCUS A LIGHT BEAM FROM ONE LIGHTING FIXTURE DIRECTLY TOWARDS ANOTHER.**

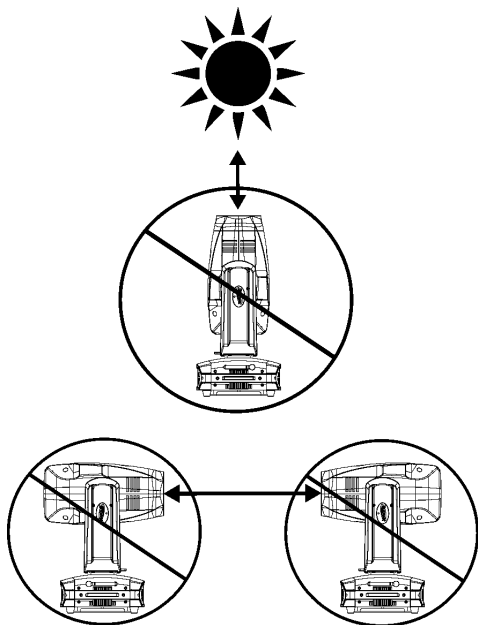

### SUN PROTECTION MODE/ HIBERNATION MODE:

This state can be set via DMX, or the device will go into this state after 3 minutes without a DMX signal.

When the sun protection is activated, the pan-and-tilt function of the moving-head will position the lens away from direct sunlight, or other high intensity light source, to protect the internal belts, electronics etc. from burn damage.

When the unit is in the 'sun protection state', it uses its accelerometer sensors (X-Y-Z) (only present on discharge units and

IP units) to position the front lens downwards, even when the unit(s) will be moved from its position. This will keep on changing the position of the head.

### Note that 'manual mode' overrides the 'sun-protection mode'.

This mode disables motors and most electronics in order to reduce wear on the fixture's internal components. The user has the ability to define the period of time that the fixture can remain inactive before it enters hibernation mode. This feature can be accessed by navigating in the main menu to PERSONALITY > STATUS SETTINGS > HIBERNATION (see the **System Menu** section of this manual for detailed information). The default setting for hibernation delay time is 15 minutes, but it can be adjusted from 1 min to 99 min, or switched off completely.



# REMOTE DEVICE MANAGEMENT (RDM)

**NOTE: In order for RDM to work properly, RDM enabled equipment must be used throughout the entire system, including DMX data splitters and wireless systems.**

Remote Device Management (RDM) is a protocol that sits on top of the DMX512 data standard for lighting, allowing the DMX systems of the fixtures to be modified and monitored remotely. This protocol is ideal for instances in which a unit is installed in a location that is not easily accessible.

With RDM, the DMX512 system becomes bi-directional, allowing a compatible RDM enabled controller to send out a signal to devices on the wire, as well as allowing the fixture to respond (known as a *GET* command). The controller can then use its *SET* command to modify settings that would typically have to be changed or viewed directly via the unit's display screen, such as the DMX Address, DMX Channel Mode, and Temperature Sensors.

## FIXTURE RDM INFORMATION:

DEVICE ID	MODEL ID	RDM CODE	PERSONALITY ID
Open	1492	0x5D4	Open

Please be aware that not all RDM devices support all RDM features, and therefore **it is important to check beforehand to ensure that the equipment that you are considering includes all of the features that you require.**

The following parameters are accessible in RDM on this device:

Sensor Definition
Sensor Value
Device Model Description
Manufacturer Label
Device Label
DMX Personality
DMX Personality Description
Device Hours
Pan Invert
Tilt Invert
Display Invert

# SYSTEM MENU

The fixture includes an easy to navigate system menu. The control panel (see image below) located on the front of the fixture, provides access to the main system menu and is where all necessary system adjustments are made to the fixture. During normal operation, pressing **MODE/ESC** button once will access the fixture's main menu. Once in the main menu you can navigate through the different functions and access the sub-menus with the **UP, DOWN, RIGHT, and LEFT** buttons. Once you reach a field that requires adjusting, press the **ENTER** button to activate that field and use the **UP** and **DOWN** buttons to adjust the field. Pressing the **ENTER** button once more will confirm your setting. You may exit the main menu at any time without making any adjustments by pressing the **MODE/ESC** button.

To access the LCD Menu Control Display via the internal battery, press and hold the **MODE/ESC** button for 3 seconds. The LCD Menu Control Display will shut **OFF** automatically about 1 minute from the last button press.

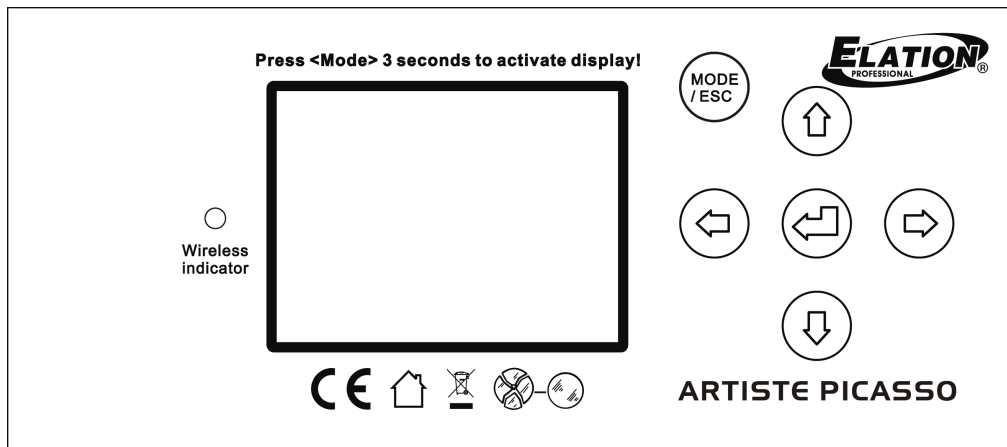

An Elation E-Loader III can be used to update the fixture to the latest software. Please visit the E-Loader III product page at the Elation web site and download the product manual for step by step instructions.

<https://www.elationlighting.com/e-loader-iii-software-uploader>

To order the E-Loader III uploader and the updated software for your fixture, please contact Elation support for details.

**ONLY QUALIFIED TECHNICIANS SHOULD PERFORM THIS FUNCTION! NOTE ALL MENU SETTINGS BEFORE UPDATING SOFTWARE! FIXTURE SOFTWARE CAN NOT BE DOWNGRADED! DOWNLOAD FIXTURE SOFTWARE TO PC ONLY! (NO MAC SUPPORT) PLEASE CONTACT ELATION SERVICE FOR FURTHER INFORMATION.**

## SYSTEM MENU - Supports Software Versions: ≥ 1.1.2

Features are subject to change without any prior written notice.

\*Rotation direction (Clockwise or Counterclockwise) of effects depends on orientation of the fixture head and Pan/Tilt settings.

MAIN MENU	SUB MENU	OPTIONS / VALUES (Default Settings in <b>BOLD</b> )		DESCRIPTION
FUNCTION	Set Dmx Address	A001~AXXX		DMX Address Setting
	Dmx Value	ALL.....		DMX Value Display
	Secondary Mode	Secondary1, Secondary2, Secondary3		Secondary Setting
	Auto Program	Primary / <b>Alone</b>		Auto Program
INFORMATION	Time Information	Current Time	XXXX (Hours)	Fixture Run Time From Power ON
		Total Run Time	XXXX (Hours)	Fixture Total Run Time
		Last Run Time	XXXX (Hours)	Fixture Last Run Time
		LastRun Password	Password= <b>038</b>	<b>(PSWD Required)</b>
		Clear Last Run	ON / <b>OFF</b>	Clear Fixture Last Run Time
	Temperature Info	Head Temperature	XXX C° / <b>F</b> °	Temperature in Fixture Head
		Base Temperature	XXX C° / <b>F</b> °	Temperature in Fixture Base
	Ethernet IP	XXX . XXX . XXX . XXX	XXX . XXX . XXX . XXX	Displays Fixture Ethernet Address
	Fan Info	HeadFan1-6, BaseFan1 / 2 (Standby, Fault)		RPM Speeds of Head/Base Fans
	Software Version	1U01: - 7U01:	≥ <b>V1.1.2</b>	Software Version
Error Info	Error Record 1 ~ Error Record 10		Fixture Last 10 Error Codes	
PERSONALITY	Status Settings	Address via DMX	<b>ON/OFF</b>	Address Via DMX
		No DMX Status	Close / <b>Hold</b> / Auto	Fixture State When NO DMX Signal
		Pan Reverse	ON/ <b>OFF</b>	Pan Reverse Movement
		Tilt Reverse	ON/ <b>OFF</b>	Tilt Reverse Movement
		Pan Degree	630/ <b>540</b>	Pan Degree Select
		Feedback	<b>ON/OFF</b>	Movement Feedback
		Hibernation	OFF, 01M~99M, <b>15M</b>	Stand By Mode
	Service Setting	Password	Password= <b>050</b>	Service Password
		RDM UID	<b>22A6xxxxxxxx</b>	RDM PID Code <b>(PSWD Required)</b>
		Clear Err. Info	ON/ <b>OFF</b>	Clear Error Info <b>(PSWD Required)</b>
		DFLT Pow. EflyOn	ON/ <b>OFF</b>	Set E-FLY Default Power State to ON
		USB Update	YES/ <b>NO</b>	Update Fixture Software (see page 20)
	Fans Control	<b>Auto</b> , High, Silent		Select Fan Speeds
	Display Setting	Shutoff Time	02~60m <b>05m</b>	Display Shut Off Time
		Display Reverse	<b>AUTO</b> , ON, OFF	Display Reverse 180°
		Key Lock	ON/ <b>OFF</b>	Key Lock
	Temperature C/F	<b>Celsius/Fahrenheit</b>		Temperature Switch Between C° / F°
	Initial Status	PAN =XXX		Initial Effect Position
	Select Signal	E-FLY Off	Disable E-FLY Wireless Transceiver	
		<b>DMX &amp; E-FLY</b>	Activate 5pin DMX and E-FLY	
		E-FLY & OUT	Activate E-FLY and 5pin DMX OUT	
		Art-Net	Select Art-Net	
		sACN	Activate sACN	
	Ethernet IP	XXX . XXX . XXX . XXX		Ethernet IP (PSWD Required)
	Ether Mask IP	XXX . XXX . XXX . XXX		Ethernet Mask IP (PSWD Required)
	Set Universe	<b>000</b> - 32767		Set Art-Net Universe
	Set E-FLY Chn	<b>00</b> - 14		Set E-FLY Wireless Channel
	Dimmer Mode	<b>Standard</b> , Stage, TV, Architectural, Theatre		Set Dimmer Curve
	Refresh	1200, 900-1500, 2500, 4000, 5000, 10000, 15000, 20000, 25000 (Hz)		Set Refresh Rate
	Gamma	2.0, <b>2.2</b> , 2.4, 2.6, 2.8		Set Gamma Value
Reset Default	ON/ <b>OFF</b>	Password= <b>011</b>	Restore Factory Settings <b>(PSWD Required)</b>	

## SYSTEM MENU - Supports Software Versions: ≥ 1.1.2

Features are subject to change without any prior written notice.

\*Rotation direction (Clockwise or Counterclockwise) of effects depends on orientation of the fixture head and Pan/Tilt settings.

MAIN MENU	SUB MENU	OPTIONS / VALUES (Default Settings in <b>BOLD</b> )		DESCRIPTION	
Reset Function	Reset All			Reset All Motors	
	Reset Pan&Tilt			Reset Pan/Tilt	
	Reset Colors			Reset Color Wheel	
	Reset Gobos			Reset Gobos	
	ResetZoomModules				
	Reset Others			Reset Other Motors	
Effect Adjust	Test Channel	PAN .....		Test function	
	Manual Control	PAN =XXX, .....		Fine Adjustments	
	Calibration	Calibration Password		Password <b>050 (PSWD Required)</b>	
User Mode Set	User Mode	<b>Standard Mode</b>		DMX Channel Modes	
		Extended Mode			
		User Mode A		User Defined Channel Assignment	
		User Mode B			
	User Mode C				
	Edit User Mode	Edit User Mode A	Max Channel = XX PAN = CH01		Edits User Defined Channel Assignments
Edit User Mode B					
Edit User Mode C					
Edit Program	Select Program	Auto Pro Part1 = Program 1~10 ( <b>Program 1</b> )		Select Programs To Be Run	
		Auto Pro Part2 = Program 1~10 ( <b>Program 2</b> )			
		Auto Pro Part3 = Program 1~10 ( <b>Program 3</b> )			
	Edit Program	Program 1	Program Test		Testing Program
		:	Step 01=SCxxx		Program In Loop
		Program 10	Step 64=SCxxx		Save and Exit
	Edit Scenes	Edit Scene 001 ~ Edit Scene 250	Pan,Tilt,.....		Save and Automatically Return
			--Fade Time-- --Scene Time--		Manual Scenes Edit
			Input By Outside		Stores Scenes via Ext DMX Console
Rec. Controller	XX~XX			Automatic Scenes Recorder	

### DMX CHANNEL VALUE CHANGE WITH SOFTWARE UPDATE VERSION ≥1.1.5

System Menu in **bolded red** has been updated with this software update, **black bolded** is default.

PERSONALITY	Select Signal	E-FLY Off	Disable E-FLY Wireless Transceiver
		<b>DMX &amp; E-FLY</b>	Activate 5pin DMX and E-FLY
		E-FLY & OUT	Activate E-FLY and 5pin DMX OUT
		Art-Net	Select Art-Net
		sACN	Activate sACN
		<b>DMX In&amp;E-FLY Out</b>	Activate 5pin DMX In and E-FLY OUT

### DMX CHANNEL VALUE CHANGE WITH SOFTWARE UPDATE VERSION ≥1.1.6

System Menu in **bolded red** has been updated with this software update, **black bolded** is default.

PERSONALITY	Fans Control	<b>Auto</b> , High, Silent, <b>Studio</b> , <b>Mute</b>	Select Fan Speeds
-------------	--------------	---	-------------------

## **PERSONALITY - Status Settings - Address Via DMX**

When ON, define the desired DMX address via an external controller.

**NOTE: This process assumes the fixture DMX address is set to 001. If fixture DMX address is not at 001, you must adjust the channel numbers accordingly for this feature to work.**

**For example: if your fixture address is 010, then Channel 1 becomes Channel 10, Channel 2 becomes Channel 11, and Channel 3 becomes Channel 12.**

1. Connect the fixture to the external controller and power ON.
2. Set the DMX value of **Channel 1** on the controller to **(7)**.
3. Set the DMX value of **Channel 2** on the controller to **(7)** or **(8)**.  
When set to **(7)**, the DMX address can be set between **(1)** and **(255)**.  
When set to **(8)**, the DMX address can be set between **(256)** and **(511)**.
4. Using **Channel 3** on the controller set the desired DMX address of the fixture.  
**Example 1:** If the desired DMX address is **57**, set **Channel 1** to a value of **(7)**, set **Channel 2** to a value of **(7)**, and then set **Channel 3** to a value of **(57)**.  
**Example 2:** If the desired DMX address is **420**, set **Channel 1** to a value of **(7)**, set **Channel 2** to a value of **(8)**, and then set **Channel 3** to a value of **(164)**. (256+164=420)
5. After setting **Channel 3** to the desired DMX address value, wait for approximately 20 seconds (some fixtures may require a longer time) for the fixture to complete the address reset function.

## **PERSONALITY – Service Setting - Password (050)**

The Service Password MUST be entered to access the service menus.

## **PERSONALITY – Service Setting - RDM UID**

Select various submenus via RDM. RDM stands for "Remote Device Management", which provides the ability to control the device remotely while connected to a DMX-bus. ANSI E1.20-2006 by ESTA specifies the RDM standard as an extension of the DMX512 protocol. Manual settings like adjusting the DMX starting address are no longer needed. This is especially useful when the device is installed in a remote area.

RDM ready and conventional DMX devices can be operated in one DMX line. The RDM protocol sends its own packages in the DMX512 data feed and does not influence conventional devices. If DMX splitters are used and RDM control is to be used, these splitters must support RDM. The number and type of RDM parameters depend on the RDM controller being used.

## PERSONALITY – Service Setting – USB Update

To update the fixture software via the **UPDATE/SERVICE PORT**, follow steps below.



**ONLY QUALIFIED TECHNICIANS SHOULD PERFORM THIS FUNCTION!**  
**NOTE ALL MENU SETTINGS BEFORE UPDATING SOFTWARE!**  
**FIXTURE SOFTWARE CAN NOT BE DOWNGRADED!**  
**DOWNLOAD FIXTURE SOFTWARE TO PC ONLY! (NO MAC SUPPORT)**  
**PLEASE CONTACT ELATION SERVICE FOR FURTHER INFORMATION.**

1. Copy fixture software update file from a PC computer to a compatible USB flash drive.  
 Make sure only the fixture software update file is stored on the USB flash drive.
2. Disconnect DMX, Art-Net, and E-FLY connections and power the fixture ON.
3. Insert USB flash drive into the **UPDATE/SERVICE PORT** on the rear connection panel.
4. Navigate to the **Personality** main menu **Service Setting / USB Update** sub menu.
5. Select the software file name on the menu display and press **ENTER**.
6. Select **YES** to begin update process and **Updating...%** will show on the menu display.
7. After file is uploaded, the fixture will check the software which will take some time.  
 The fixture will perform a reset process when the software update process is complete.
8. Remove the USB flash drive and make necessary system menu setting adjustments.

## PERSONALITY - Display Setting – Key Lock

When ON, Control Panel buttons lock automatically after exiting main menu for 15 seconds. To unlock, keep **MODE/ESC** button pressed for 3 seconds.

## PERSONALITY - Dimmer Mode

Select desired DIMMER MODE (Standard, Stage, TV, Architectural, Theatre).

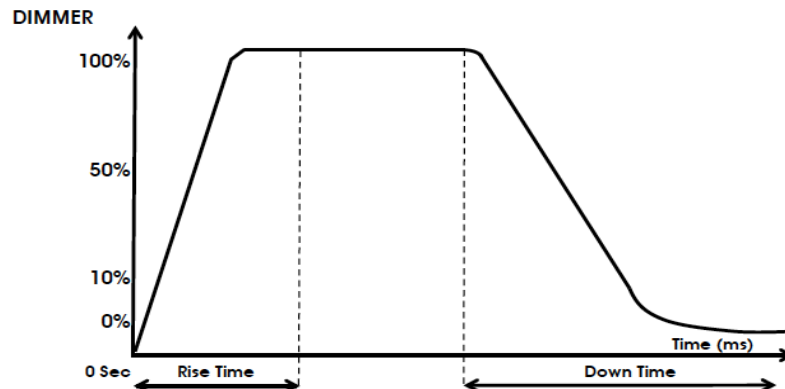

Dimming Curve Ramp Effect	0 sec Fade Time		1 sec Fade Time	
	Rise Time (ms)	Down Time (ms)	Rise Time (ms)	Down Time (ms)
Standard (default)	0	0	0	0
Stage	780	1100	1540	1660
TV	1180	1520	1860	1940
Architectural	1380	1730	2040	2120
Theatre	1580	1940	2230	2280

## **PERSONALITY - Reset Default (011)**



**ONLY QUALIFIED TECHNICIANS SHOULD PERFORM THIS FUNCTION!**

**NOTE: SAVED WHITE BALANCE IS ERASED AFTER A RESET IS PERFORMED!**

This function restores all fixture settings to the factory default settings. The password is **011** and must be entered each time a reset is performed.

## **EFFECT ADJUST – Test Channel**

Auto test each individual channel function independently from the DMX control board.

## **EFFECT ADJUST – Manual Control**

Select and manually test and fine adjust each individual channel function

Independently from DMX control board. This function will center PAN and TILT motors and set dimmer to 100%. PAN and TILT functions will still operate if the fixture needs to be positioned to a flat clear surface. With the individual functions, you can focus the light on a flat surface (wall) and perform fine adjustments.

## **EFFECT ADJUST – Calibration**



**ONLY QUALIFIED TECHNICIANS SHOULD PERFORM THIS FUNCTION.**

This function allows small adjustments to be made to the Pan, Tilt, and Zoom movements to compensate for wear or in the event a sensor has been knocked slightly out of place. Because improper use of this function can result in undesired operation this function has been password protected. The password is **050** and must be entered each time the calibration menu function is entered. Because calibration is an extremely delicate procedure, instructions on performing this action are left out of this manual. For a first-time calibrator, please contact our customer support team for step-by-step instructions.

## **USER MODE SET – Edit User Mode**

Create user defined channel orders allowing the fixture to match the channel order of other fixtures on the market for easier operation. A total of three user modes may be configured: User Mode A, User Mode B, and User Mode C.

## **EDIT PROGRAM – Rec. Controller**

The fixture features an integrated DMX-recorder by which you can transmit the programmed scenes from your DMX-controller to the moving head. Adjust the desired scene numbers via the encoder (from – to). When you call up the scenes at your controller, they will automatically be transmitted to the moving head.

## **EDIT PROGRAM – Record Controller – Working with Built-In Programs**

A Primary unit can send up to 3 different data groups to the Secondary units, i.e., a Primary unit can start 3 different Secondary units, which run 3 different programs. The Primary unit sends the 3 program parts in a continuous loop.



The Secondary unit receives data from the Primary unit according to the group which the Secondary unit was assigned to. If e.g., a Secondary unit is set to “**Secondary 1**” in the menu “**Set to Secondary**”, the Primary unit sends “**Auto Program Part 1**” to the Secondary unit.

If set to “**Secondary 2**”, the Secondary unit receives “**Auto Program Part 2**”.

To start an Auto Program, proceed as follows:

### **1. Secondary Setting**

- Select “**Function Mode**”.
- Press **ENTER** to confirm.
- Select “**Set to Secondary**”.
- Press **ENTER** to confirm.
- Select “**Secondary 1**”, “**Secondary 2**” or “**Secondary 3**”.
- Press **ENTER** to confirm.
- Press **MODE/ESC** to return to the main menu.

### **2. Automatic Program Run**

- Select “**Function Mode**”.
- Press **ENTER** to confirm.
- Select “**Auto Program**”.
- Press **ENTER** to confirm.
- Select “**Primary**” or “**Alone**”.
- Press **ENTER** to confirm.
- Press **MODE/ESC** in order to return to the main menu.



## **EDIT PROGRAM – Record Controller – Working with Built-In Program [continued]**

### **3. Program Selection for Auto Pro Part**

- Select “**Edit Program**”.
- Press **ENTER** to confirm.
- Select “**Select Programs**”.
- Press **ENTER** to confirm.
- Select “**Auto Pro Part 1**”, “**Auto Pro Part 2**” or “**Auto Pro Part 3**”, and select which Secondary program is to be sent. Selection “**Part 1**” means, that the Secondary unit runs the same program as the primary units.
- Press **ENTER** to confirm.
- Press **MODE/ESC** to return to the main menu.

### **4. Program Selection for Edit Program**

- Select “**Edit Program**”.
- Press **ENTER** to confirm.
- Select “**Edit Program**”.
- Press **ENTER** to confirm.
- Select the desired program to edit specific scenes into a specific program.
- Press **ENTER** to confirm.
- Press **MODE/ESC** to return to the main menu.

### **5. Automatic Scene Recording**

- Select “**Edit Program**”.
- Press **ENTER** to confirm.
- Select “**Edit Scenes**”.
- Select desired scene numbers. A maximum of 250 scenes can be programmed.
- Press **ENTER** to confirm.
- Press **MODE/ESC** to return to the main menu.

## **EDIT PROGRAM – Record Controller – Working with Built-In Program [continued]**

### **Example:**

Program 2 includes scenes: 10, 11, 12, & 13

Program 4 includes scenes: 8, 9, & 10

Program 6 includes scenes: 12, 13, 14, & 15

Auto Pro Part 1 is Program 2

Auto Pro Part 2 is Program 3

Auto Pro Part 3 is Program 6

The 3 Secondary groups run the Auto Program in certain time segments. (See diagram below)

#### **Part 1:**

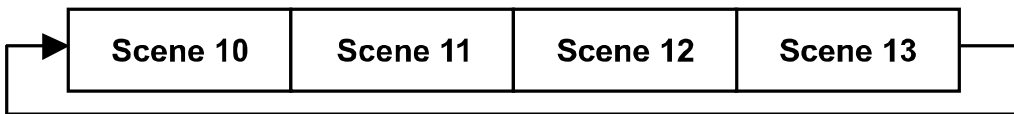

#### **Part 2:**

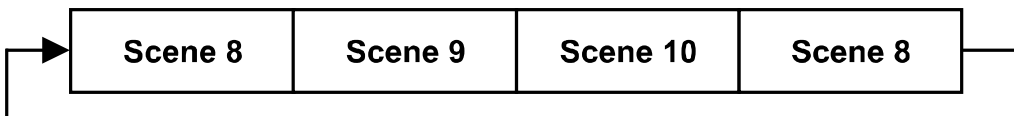

#### **Part 3:**

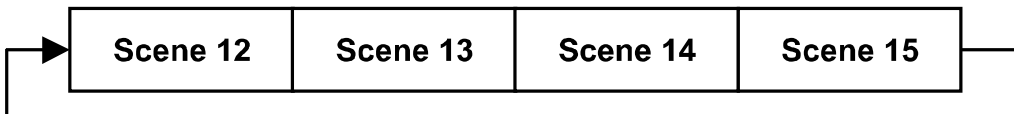

## FAN MODES

The Artiste Picasso is a high-performance fixture suited for multiple applications. For noise critical environments such as Theater, Opera, or Orchestral Halls, it offers various fan operation modes which remove unwanted noise distractions for the audience and performers. Fan Modes can be changed remotely via the DMX control channel, allowing the fixture to offer high output or whisper-silent operation at a moment's notice. All Fan Modes smoothly transition over a brief period, preventing unwanted attraction to the fixture.

**Auto (Default)** – Fans only run at the speeds needed to keep the LED engine within a safe temperature range, and ensures optimal performance of the fixture. They will turn off if possible; for example, when the fixture is dimmed to a low intensity. Fans sense the ambient and fixture temperature and will, at all times, try to keep noise levels at a minimum. The fixture output will only be reduced when the LED engine cannot be cooled to its safe operating range due to a high ambient temperature.

**NOTE:** This mode is recommended for daily operation.

**Silent** – Fan speeds are reduced throughout the fixture for a lower noise profile. The fixture output is also reduced to approximately 80%. This mode should be sufficient for most uses where lower noise is required.

**High** – Fan speeds are increased throughout the fixture for the most efficient cooling. This mode will increase wear on the fans and should only be utilized in exceptional circumstances. Fans will always run, even if the fixture is dimmed. Fixture output is kept at 100% unless the LED engine temperature reaches an unsafe temperature, at which point the fixture will reduce power carefully to ensure continued safe operation. This mode is only required in very high ambient temperatures when automatic fan speed adjustments are not desired.

**Studio** – All fans run at low speed. The fixture LED output is reduced to 75-80%.

**Mute** – All but one fixture fan is turned off for whisper-quiet operation. The fixture LED power output is reduced to 25%.

*Note: Studio and Mute modes only available with software version 1.1.6 and higher.*

# E-FLY WIRELESS DMX SET UP



**BEFORE SETTING THE WIRELESS CHANNEL ON ANY E-FLY FIXTURE, MAKE SURE THE SOURCE E-FLY WIRELESS DMX TRANSCEIVER DEVICE IS OFF.**

## TO CONTROL FIXTURE WITH E-FLY WIRELESS DMX SIGNAL

1. Ensure the source **E-FLY** wireless DMX Transceiver device is powered **OFF**.
2. Power **ON** fixture and from the LCD control panel select **DMX & E-FLY** or **E-FLY & OUT** in the **Select Signal** sub menu of the **PERSONALITY** main system menu.
3. From the LCD control panel set the **E-FLY** wireless channel to the same wireless channel of the source **E-FLY** DMX Transceiver device in the **Set E-FLY Chn** sub menu of the **PERSONALITY** main system menu.



**NOTE:** Erratic fixture movement may occur if other **E-FLY** wireless DMX products are in use in the same area and are using the same **E-FLY** wireless channel. The fixture may immediately start to respond to the DMX wireless signal from another **E-FLY** wireless DMX Transceiver immediately when **E-FLY** is enabled. Make sure to know what **E-FLY** wireless channels are being used in the area where the fixture is being installed.

## RELATION E-FLY WIRELESS TRANSCEIVER has 0-14 wireless channels.

4. Set fixture DMX address in the **Set Dmx Address** sub menu of the **FUNCTION** main system menu.
5. The **E-FLY** signal Indicator on the fixture LCD control display will illuminate **GREEN** if a successful wireless DMX connection has been made or illuminate **RED** for NO connection. If no connection is made, repeat steps 1-4 above.
6. Repeat this process for all **E-FLY** compatible fixtures in the E-FLY wireless network, making sure all fixtures are assigned the same **E-FLY** wireless channel.
7. After all fixtures in the **E-FLY** wireless network have been set to the same **E-FLY** wireless channel and powered ON, now power ON the source **E-FLY** DMX Transceiver device.
8. Test all fixtures connected to the **E-FLY** wireless network to confirm proper functionality.

## E-FLY WIRELESS INSTALLATION LOCATION GUIDELINES

There are many factors that affect and/or interrupt a wireless signal such as walls, glass, metal, objects, and people. Therefore, it is highly recommended to:

- Install devices a minimum of 9.8 ft. (3m) above audiences and/or ground level
- Adjust the wireless antenna in a vertical upright position
- Position devices in direct line of sight of the controlling E-FLY device

Careful planning and testing of the selected installation location is critical to ensure optimum and reliable wireless operation.

9.8 ft (3m)  
Above Ground



# DMX CHANNEL FUNCTIONS AND VALUES

## RELATION ARTISTE PICASSO

DMX Channel Values / Functions (62 DMX Channels)

**Supports Software Versions:  $\geq$  1.1.2**

Features are subject to change without any prior written notice.

\*Rotation direction (Clockwise or Counterclockwise) of effects depends on orientation of the fixture head and Pan/Tilt settings.

MODE / CHANNEL		VALUE	FUNCTION
STANDARD	EXTENDED		
1	1		PAN MOVEMENT
		0-255	PAN Movement
2	2		PAN FINE MOVEMENT [16 BIT]
		0-255	Fine Control of PAN Movement
3	3		TILT MOVEMENT
		0-255	TILT Movement
4	4		TILT MOVEMENT [16 BIT]
		0-255	Fine Control of TILT Movement
5	5		CYAN COLOR
		0-255	0-WHITE ~ 255-100% CYAN
	6		CYAN COLOR FINE [16 BIT]
		0-255	CYAN FINE Adjustment
6	7		MAGENTA COLOR
		0-255	0-WHITE ~ 255-100% MAGENTA
	8		MAGENTA COLOR FINE [16 BIT]
		0-255	MAGENTA FINE Adjustment
7	9		YELLOW COLOR
		0-255	0-WHITE ~ 255-100% YELLOW
	10		YELLOW COLOR FINE [16 BIT]
		0-255	YELLOW FINE Adjustment
8	11		CTO COLOR
		0-255	0-WHITE ~ 255-100% CTO
	12		CTO COLOR FINE [16 BIT]
		0-255	CTO FINE Adjustment
9	13		COLOR WHEEL
		0-19	OPEN / WHITE
		20-37	Color 1
		38-55	Color 2
		56-73	Color 3
		74-91	Color 4
		92-109	Color 5
		110-127	Color 6
		128-189	*Clockwise COLOR Rotation from FAST to SLOW
		190-193	NO Rotation
194-255	*Counter-Clockwise COLOR Rotation from SLOW to FAST		
	14		COLOR WHEEL FINE ADJUSTMENT [16 BIT]
		0-255	FINE Adjustment of Color Wheel to Any Position

MODE / CHANNEL		VALUE	FUNCTION
STANDARD	EXTENDED		
10	15		<b>ROTATING GOBOS, CONTINUOUS ROTATION [GOBO WHEEL 1]</b>
		0-9	OPEN
		10-19	Rotating Gobo 1
		20-29	Rotating Gobo 2
		30-39	Rotating Gobo 3
		40-49	Rotating Gobo 4
		50-59	Rotating Gobo 5
		60-69	Rotating Gobo 6
		70-77	Rotating Gobo 7
		78-93	Gobo 1 Shake SLOW to FAST
		94-109	Gobo 2 Shake SLOW to FAST
		110-125	Gobo 3 Shake SLOW to FAST
		126-141	Gobo 4 Shake SLOW to FAST
		142-157	Gobo 5 Shake SLOW to FAST
		158-173	Gobo 6 Shake SLOW to FAST
		174-189	Gobo 7 Shake SLOW to FAST
		190-221	*Clockwise Gobo Wheel Rotation from FAST to SLOW
222-223	NO Rotation		
224-255	*Counter-Clockwise Gobo Wheel Rotation from SLOW to FAST		
11	16		<b>ROTATING GOBOS, INDEX ROTATION [GOBO WHEEL 1]</b>
		0-127	Gobo Indexing
		128-189	*Clockwise Gobo Rotation from FAST TO SLOW
		190-193	NO Rotation
194-255	*Counter-Clockwise Gobo Rotation from SLOW to FAST		
12	17		<b>ROTATING GOBOS, FINE INDEX ROTATION [GOBO WHEEL 1] [16 BIT]</b>
		0-255	Gobo Rotation FINE Indexing
13	18		<b>STATIC / FIXED GOBOS [GOBO WHEEL 2]</b>
		0-9	OPEN
		10-19	Static / Fixed Gobo 1
		20-29	Static / Fixed Gobo 2
		30-39	Static / Fixed Gobo 3
		40-49	Static / Fixed Gobo 4
		50-59	Static / Fixed Gobo 5
		60-69	Static / Fixed Gobo 6
		70-77	Static / Fixed Gobo 7
		78-93	Shake SLOW to FAST Static / Fixed Gobo 1
		94-109	Shake SLOW to FAST Static / Fixed Gobo 2
		110-125	Shake SLOW to FAST Static / Fixed Gobo 3
		126-141	Shake SLOW to FAST Static / Fixed Gobo 4
		142-157	Shake SLOW to FAST Static / Fixed Gobo 5
		158-173	Shake SLOW to FAST Static / Fixed Gobo 6
		174-189	Shake SLOW to FAST Static / Fixed Gobo 7
		190-221	*Clockwise Gobo Wheel Rotation from FAST to SLOW
222-223	No rotation		
224-255	*Counter-Clockwise Gobo Wheel Rotation from SLOW to FAST		
	19		<b>STATIC / FIXED GOBOS, FINE INDEX ROTATION [GOBO WHEEL 2] [16 BIT]</b>
		0-255	Gobo Rotation FINE Indexing

MODE / CHANNEL		VALUE	FUNCTION
STANDARD	EXTENDED		
14	20		<b>ROTATING PRISM, PRISM / GOBO MACROS</b>
		0-63	OPEN
		64-95	PRISM 1
		96-127	PRISM 2
		128-135	Prism / Gobo Macro 1
		136-143	Prism / Gobo Macro 2
		144-151	Prism / Gobo Macro 3
		152-159	Prism / Gobo Macro 4
		160-167	Prism / Gobo Macro 5
		168-175	Prism / Gobo Macro 6
		176-183	Prism / Gobo Macro 7
		184-191	Prism / Gobo Macro 8
		192--199	Prism / Gobo Macro 9
		200-207	Prism / Gobo Macro 10
		208-215	Prism / Gobo Macro 11
		216-223	Prism / Gobo Macro 12
224-231	Prism / Gobo Macro 13		
232-239	Prism / Gobo Macro 14		
240-247	Prism / Gobo Macro 15		
248-255	Prism / Gobo Macro 16		
15	21		<b>ROTATING PRISM #1, PRISM #1 INDEX ROTATION</b>
		0-127	Prism Indexing
		128-189	*Clockwise Prism Rotation from FAST to SLOW
		190-193	NO Rotation
		194-255	*Counter-Clockwise Prism Rotation from SLOW to FAST
	22		<b>ROTATING PRISM #1, PRISM #1 FINE INDEX ROTATION [16 BIT]</b>
		0-255	Gobo Rotation FINE Indexing
16	23		<b>ROTATING PRISM #2, PRISM #2 INDEX ROTATION</b>
		0-127	Prism Indexing
		128-189	*Clockwise Prism Rotation from FAST to SLOW
		190-193	NO Rotation
		194-255	*Counter-Clockwise Prism Rotation from SLOW to FAST
	24		<b>ROTATING PRISM #2, PRISM #2 FINE INDEX ROTATION [16 BIT]</b>
		0-255	Gobo Rotation FINE Indexing
17	25		<b>FOCUS</b>
		0-255	Continuous Adjustment from NEAR to FAR
18	26		<b>FOCUS FINE [16 BIT]</b>
		0-255	Continuous FINE Focus Adjustment
19	27		<b>MOTORIZED ZOOM</b>
		0-255	ZOOM Adjustment from SMALL to BIG
	28		<b>MOTORIZED ZOOM FINE [16 BIT]</b>
		0-255	ZOOM FINE Adjustment



MODE / CHANNEL		VALUE	FUNCTION
STANDARD	EXTENDED		
			<b>AUTO FOCUS</b>
		0-10	AUTO FOCUS OFF
		11-20	3.5m
		21-30	4m
		31-40	4.5m
		41-50	5m
		51-60	5.5m
		61-70	6m
		71-80	6.5m
		81-90	7m
		91-100	7.5m
		101-110	8m
	29	111-120	8.5m
		121-130	9m
		131-140	9.5m
		141-150	10m
		151-160	10.5m
		161-170	11m
		171-180	11.5m
		181-190	12m
		191-200	12.5m
		201-210	13m
		211-220	13.5m
		221-230	14m
		231-240	14.5m
		241-255	15m
	30		<b>AUTO FOCUS FINE</b>
		0-255	Continuous FINE Focus Adjustment
			<b>SHUTTER, STROBE</b>
		0-31	Shutter CLOSED
		32-63	NO Function (Shutter OPEN)
		64-95	Strobe Effect SLOW to FAST
	31	96-127	NO Function (Shutter OPEN)
		128-159	Pulse Effect In Sequences
		160-191	NO Function (Shutter OPEN)
		192-223	Random Strobe Effect SLOW to FAST
		224-255	NO Function (Shutter OPEN)
20			<b>DIMMER INTENSITY</b>
	32	0-255	Intensity 0 to 100%
			<b>DIMMER INTENSITY FINE [16 BIT]</b>
21	33	0-255	Intensity 0 to 100%
22			<b>DIMMER INTENSITY FINE [16 BIT]</b>
		0-255	Intensity 0 to 100%

MODE / CHANNEL		VALUE	FUNCTION
STANDARD	STANDARD		
23	34		<b>DIMMER CURVE MODES</b>
		0-20	STANDARD
		21-40	STAGE
		41-60	TV
		61-80	ARCHITECTURAL
		81-100	THEATER
		101-120	STAGE2
			<b>DIMMER DELAY TIME</b>
		121	0s
		122	0.1s
		123	0.2s
		124	0.3s
		125	0.4s
		126	0.5s
		127	0.6s
		128	0.7s
		129	0.8s
		130	0.9s
		131	1.0s
		132	1.5s
		133	2.0s
		134	3.0s
		135	4.0s
		136	5.0s
		137	6.0s
		138	7.0s
139	8.0s		
140	9.0s		
141	10.0s		
142-255	Idle		

**DMX CHANNEL VALUE CHANGE WITH SOFTWARE UPDATE VERSION ≥1.1.7**

Gray highlighted DMX Channel below shows updates with this software version.

23	34		<b>DIMMER CURVE MODES</b>
		0-20	STANDARD
		21-40	STAGE
		41-60	TV
		61-80	ARCHITECTURAL
		81-100	THEATER
		101-120	DEFAULT to FIXTURE DIMMER CURVE SETTING
			<b>DIMMER DELAY TIME</b>
		121	0s
		122	0.1s
		123	0.2s
		124	0.3s
		125	0.4s
		126	0.5s
		127	0.6s
		128	0.7s
		129	0.8s
		130	0.9s
		131	1.0s
		132	1.5s
		133	2.0s
		134	3.0s
		135	4.0s
		136	5.0s
		137	6.0s
		138	7.0s
139	8.0s		
140	9.0s		
141	10s		
142-255	IDLE		

MODE / CHANNEL		VALUE	FUNCTION
STANDARD	STANDARD		
24	35		<b>IRIS</b>
		0-191	MAX to MIN Diameter
		192-223	Pulse Closing FAST to SLOW
		224-255	Pulse Opening SLOW to FAST
	36		<b>IRIS FINE</b>
		0-255	Iris FINE Adjustment
25	37		<b>FROST</b>
		0-126	OPEN TO FROST 1
		127	100% FROST 1
		128-254	OPEN to FROST 2
26	38		<b>ANIMATION WHEEL</b>
		0-7	OPEN
		8-127	*Clockwise Animation Wheel Rotation from FAST to SLOW
		128-135	NO Rotation
		136-255	*Counter-Clockwise Animation Wheel Rotation from SLOW to FAST
	39		<b>CMY / COLOR MACRO SPEED</b>
		0-255	MAX to MIN Speed
	40		<b>CMY / COLOR MACROS</b>
		0-31	OFF
		32-39	Macro 1
		40-47	Macro 2
		48-55	Macro 3
		56-63	Macro 4
		64-71	Macro 5
		72-79	Macro 6
		80-87	Macro 7
		88-95	Macro 8
		96-103	Macro 9
		104-111	Macro 10
		112-119	Macro 11
		120-127	Macro 12
		128-135	Macro 13
		136-143	Macro 14
		144-151	Macro 15
		152-159	Macro 16
		160-167	Macro 17
		168-175	Macro 18
		176-183	Macro 19
		184-191	Macro 20
		192-199	Macro 21
		200-207	Macro 22
		208-215	Macro 23
		216-223	Macro 24
		224-231	Macro 25
232-239	Macro 26		
240-247	Macro 27		
248-255	RANDOM CMY		

MODE / CHANNEL		VALUE	FUNCTION
STANDARD	EXTENDED		
27	41		BLADE 1A
		0-255	Open to Close
	42		BLADE 1A Fine
		0-255	Open to Close Fine
28	43		BLADE 1B
		0-255	Open to Close
	44		BLADE 1B Fine
		0-255	Open to Close Fine
29	45		BLADE 2A
		0-255	Open to Close
	46		BLADE 2A Fine
		0-255	Open to Close Fine
30	47		BLADE 2B
		0-255	Open to Close
	48		BLADE 2B Fine
		0-255	Open to Close Fine
31	49		BLADE 3A
		0-255	Open to Close
	50		BLADE 3A Fine
		0-255	Open to Close Fine
32	51		BLADE 3B
		0-255	Open to Close
	52		BLADE 3B Fine
		0-255	Open to Close Fine
33	53		BLADE 4A
		0-255	Open to Close
	54		BLADE 4A Fine
		0-255	Open to Close Fine
34	55		BLADE 4B
		0-255	Open to Close
	56		BLADE 4B Fine
		0-255	Open to Close Fine
35	57		ALL BLADE Rotation
		0-255	All Blade Rotation
	58		ALL BLADE Rotation Fine
		0-255	All Blade Rotation Fine
	59		BLADE Speed
		0-255	Speed MAX to MIN

MODE / CHANNEL		VALUE	FUNCTION
STANDARD	EXTENDED		
			<b>BLADE MACROS</b>
		0-7	OFF
		8-15	Macro 01
		16-23	Macro 02
		24-31	Macro 03
		32-39	Macro 04
		40-47	Macro 05
		48-55	Macro 06
		56-63	Macro 07
		64-71	Macro 08
		72-79	Macro 09
		80-87	Macro 10
		88-95	Macro 11
		96-103	Macro 12
		104-111	Macro 13
		112-119	Macro 14
	60	120-127	Macro 15
		128-135	Macro 16
		136-143	Macro 17
		144-151	Macro 18
		152-159	Macro 19
		160-167	Macro 20
		168-175	Macro 21
		176-183	Macro 22
		184-191	Macro 23
		192-199	Macro 24
		200-207	Macro 25
		208-215	Macro 26
		216-223	Macro 27
		224-231	Macro 28
		232-239	Macro 29
		240-247	Macro 30
		248-255	Macro 31
			<b>PAN / TILT MOVEMENT SPEED</b>
		0-225	MAX to MIN Speed
	61	226-235	Blackout by Movement
		236-245	Blackout by ALL Wheel Movement
		246-255	NO FUNCTION

MODE / CHANNEL		VALUE	FUNCTION
STANDARD	EXTENDED		
36	62		<b>SPECIAL FUNCTIONS</b>
		0-19	COLOR & GOBO Change Normal
		20-29	COLOR Change to Any Position
		30-39	COLOR & GOBO Change to Any Position
		40-44	Low Noise – Mute
		45-49	Low Noise – Studio
		50-59	Fan Control – Low
		60-69	Fan Control – High
		70-79	Fan Control – Auto
		80-84	All motor reset
		85-87	Scan motor reset
		88-90	Colors motor reset
		91-93	Gobo motor reset
		94-96	Focus & zoom motor reset
		97-99	Other motor reset
			<b>REFRESH RATE</b>
		100	900 Hz
		101	910 Hz
		102	920 Hz
		103	930 Hz
		104	940 Hz
		105	950 Hz
		106	960 Hz
		107	970 Hz
		108	980 Hz
		109	990 Hz
		110	1000 Hz
		111	1010 Hz
		112	1020 Hz
		113	1030 Hz
114	1040 Hz		
115	1050 Hz		
116	1060 Hz		
117	1070 Hz		
118	1080 Hz		
119	1090 Hz		
120	1100 Hz		
121	1110 Hz		
122	1120 Hz		
123	1130 Hz		
124	1140 Hz		
125	1150 Hz		
126	1160 Hz		
127	1170 Hz		
128	1180 Hz		
129	1190 Hz		
130	1200 Hz		

MODE / CHANNEL		VALUE	FUNCTION
STANDARD	EXTENDED		
36	62		<b>REFRESH RATE</b>
		131	1210 Hz
		132	1220 Hz
		133	1230 Hz
		134	1240 Hz
		135	1250 Hz
		136	1260 Hz
		137	1270 Hz
		138	1280 Hz
		139	1290 Hz
		140	1300 Hz
		141	1310 Hz
		142	1320 Hz
		143	1330 Hz
		144	1340 Hz
		145	1350 Hz
		146	1360 Hz
		147	1370 Hz
		148	1380 Hz
		149	1390 Hz
		150	1400 Hz
		151	1410 Hz
		152	1420 Hz
		153	1430 Hz
		154	1440 Hz
		155	1450 Hz
		156	1460 Hz
		157	1470 Hz
		158	1480 Hz
		159	1490 Hz
		160	1500 Hz
		161	2500 Hz
		162	4000 Hz
		163	5000 Hz
		164	6000 Hz
		165	10,000 Hz
166	15,000 Hz		
167	20,000 Hz		
168	25,000 Hz		
			<b>MISCELLANEOUS FUNCTIONS</b>
		169-180	Reserved
		181-185	Dimmer Curve Linear (Default)
		186-190	Dimmer Curve Square
		191-195	Dimmer Curve Inverse Square
		196-200	Dimmer Curve S-Curve
		201	Internal Program 1 (Scenes 1-8)
		202	Internal Program 2 (Scenes 9-16)

MODE / CHANNEL		VALUE	FUNCTION
STANDARD	EXTENDED		
36	62		<b>MISCELLANEOUS FUNCTIONS</b>
		203	Internal Program 3 (Scenes 17-24)
		204	Internal Program 4 (Scenes 25-32)
		205	Internal Program 5 (Scenes 33-40)
		206	Internal Program 6 (Scenes 41-48)
		207	Internal Program 7 (Scenes 49-56)
		208-209	Hibernate Off
		210-211	Hibernate On
		212-255	Reserved



## ERROR CODES

When power is applied, the unit will automatically enter a **“Reset/Test”** mode. This mode brings all the internal motors to a home position. If there is an internal problem with one or more of the motors an error code will flash in the display in the form of **“XXer”** where as XX will represent a function number. For example, when the display shows **“0Er”** it means there is some type of error with the Pan motor. If there are multiple errors during the start-up process, they will all flash in the display. For example: if the fixtures have errors on **Channel 1, 2, and 5** all at the same time, you will see the error message **“01Er”, “02Er”, and “05Er”** flash repeated 5 times.

If an error does occur during the initial start-up procedure the fixture will self-generate a second reset signal and try to realign all the motors and correct the errors. If the error persists after a second attempt a third attempt will be made. If after a third attempt all the errors have not been corrected the fixture will make the following determinations:

- **3 or More Errors:** The fixture cannot function properly with three or more errors therefore the fixture will place itself in a stand-by mode until subsequent repairs can be made.
- **Less Than 3 Errors:** The fixture has less than 3 errors; therefore, most other functions will work properly. The fixture will attempt to operate normally until the errors can be corrected by a technician. The errors in question will remain flashing in the display as a reminder of internal errors.

## ERROR CODES

Error Codes are subject to change without any prior written notice.

ERROR CODES	DESCRIPTION
<b>PAN Er</b>	Movement is not located in the default position after the reset. This message will appear after a fixture reset if the magnetic-indexing circuit malfunctions (sensor failed, or magnet is missing) or there is a motor failure (defective motor or a defective motor IC drive on the main PCB). This error may also be displayed if the head/yoke was blocked during a reset function.
<b>TILT Er</b>	
<b>Cyan Color Wheel Er</b>	Movement is not located in the default position after the reset. This message will appear after a fixture reset if the magnetic-indexing circuit malfunctions (sensor failed, or magnet is missing) or there is a motor failure (defective motor or a defective motor IC drive on the main PCB).
<b>Magenta Color Wheel Er</b>	
<b>Yellow Color Wheel Er</b>	
<b>CTO Color Wheel Er</b>	
<b>Color Wheel Er</b>	
<b>Gobo Wheel 1 Er</b>	
<b>Gobo Rot. 1 Wheel Er</b>	
<b>Fixed Gobo Wheel Er</b>	
<b>Animation Wheel Er</b>	
<b>Prim 1 Wheel Er</b>	
<b>Prism Rot. 1 Wheel Er</b>	
<b>Prism 2 Wheel Er</b>	
<b>Prism Rot. 2 Wheel Er</b>	
<b>Zoom Wheel Er</b>	
<b>Focus Wheel Er</b>	
<b>Frost 1 Wheel Er</b>	
<b>Frost 2 Wheel Er</b>	
<b>Iris Wheel Er</b>	
<b>Blade 1 Wheel Er</b>	
<b>Blade 1 Rot Wheel Er</b>	
<b>Blade 2 Wheel Er</b>	
<b>Blade 2 Rot Wheel Er</b>	
<b>Blade 3 Wheel Er</b>	
<b>Blade 3 Rot Wheel Er</b>	
<b>Blade 4 Wheel Er</b>	
<b>Blade 4 Rot Wheel Er</b>	
<b>Frame Rot Wheel Er</b>	

# SPECIFICATIONS

## SOURCE

620W 6,800K Cool White LED Engine  
30,000 Hour Average LED Life\*

\*Test lab conditions. May vary depending on several factors including but not limited to:  
Environmental Conditions, Power/Voltage, Usage Patterns (On-Off Cycling), Control, and Dimming.

## PHOTOMETRIC DATA

23,000+ Total Lumen Output  
CRI 73 (87+ with HCRI filter)  
Zoom Range 7° - 55°  
Beam Angle 6.7° - 47.9°  
Field Angle 8.2° - 56°

## EFFECTS

Motorized Zoom  
4 Rotating Full Blackout Framing Blades  
+/-45° Framing Indexing  
Full 360° Bi-Directional Animation Wheel  
4-Facet and Linear Rotating Prisms  
2 Frost Filters  
Internal Color, Framing, Prism, and Frost Macros  
Motorized Iris with Variable Pulse Effects  
Variable 16-bit Dimming Curve Modes  
High Speed Electronic Shutter and Strobe  
Adjustable LED Refresh Rate Frequency and Gamma  
Pan Angle: 540°/630°  
Tilt Angle: 246°

## COLOR

Full CMY Color Mixing System  
Linear CTO Color Correction  
6 Dichroic Colors including High 87 CRI Filter

## GOBOS

2 Gobo Wheels  
7 Rotating / Indexing Interchangeable Glass Gobos  
7 Interchangeable Static-Stamped Metal Gobos

## CONTROL / CONNECTIONS

2 DMX Channel Modes (36 / 62 channels)  
16-bit Pan, Tilt, and Dimming Control  
Motorized Focus and 5-15m Auto-Focus Presets  
DMX, RDM, Art-NET, and sACN Protocol Support  
Elation's E-FLY™ Internal Wireless DMX Transceiver  
6 Button Touch Control Panel  
Full Color 180° Reversible LCD Menu Display  
8 / 16 Bit Resolution Adjustable Movement  
Hibernation Mode (Power Save)  
Locking 5pin XLR DMX, RJ45 Ethernet, and Power  
With Wired Digital Communication Network

## SIZE / WEIGHT

Length: 18.0" (457mm)  
Width: 21.5" (544.5mm)  
Vertical Height: 29.8" (757.5mm)  
Weight: 84.0 lbs. (38.1kg)

## ELECTRICAL / THERMAL

AC 100-240V - 50/60Hz  
1000W Max Power Consumption  
14°F to 113°F (-10°C to 45°C)  
BTU/hr (+/- 10%) 3410

## APPROVALS / RATINGS

CE | cETLus | IP20

Specifications and improvements in the design of this unit and this manual are subject to change without any prior written notice.

# DIMENSIONAL DRAWINGS

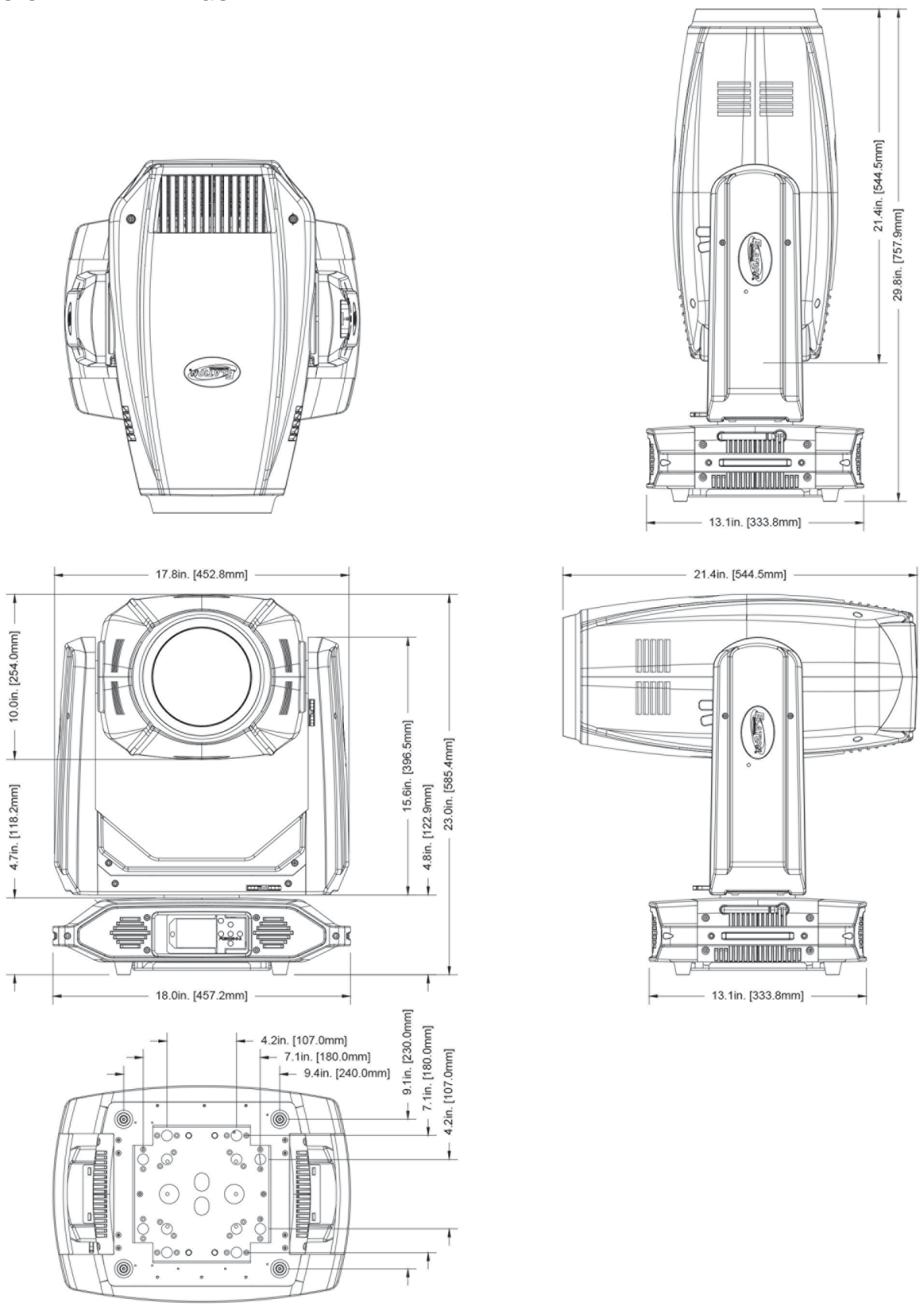

Specifications and improvements in the design of this unit and this manual are subject to change without any prior written notice.

# DIMENSIONAL DRAWINGS

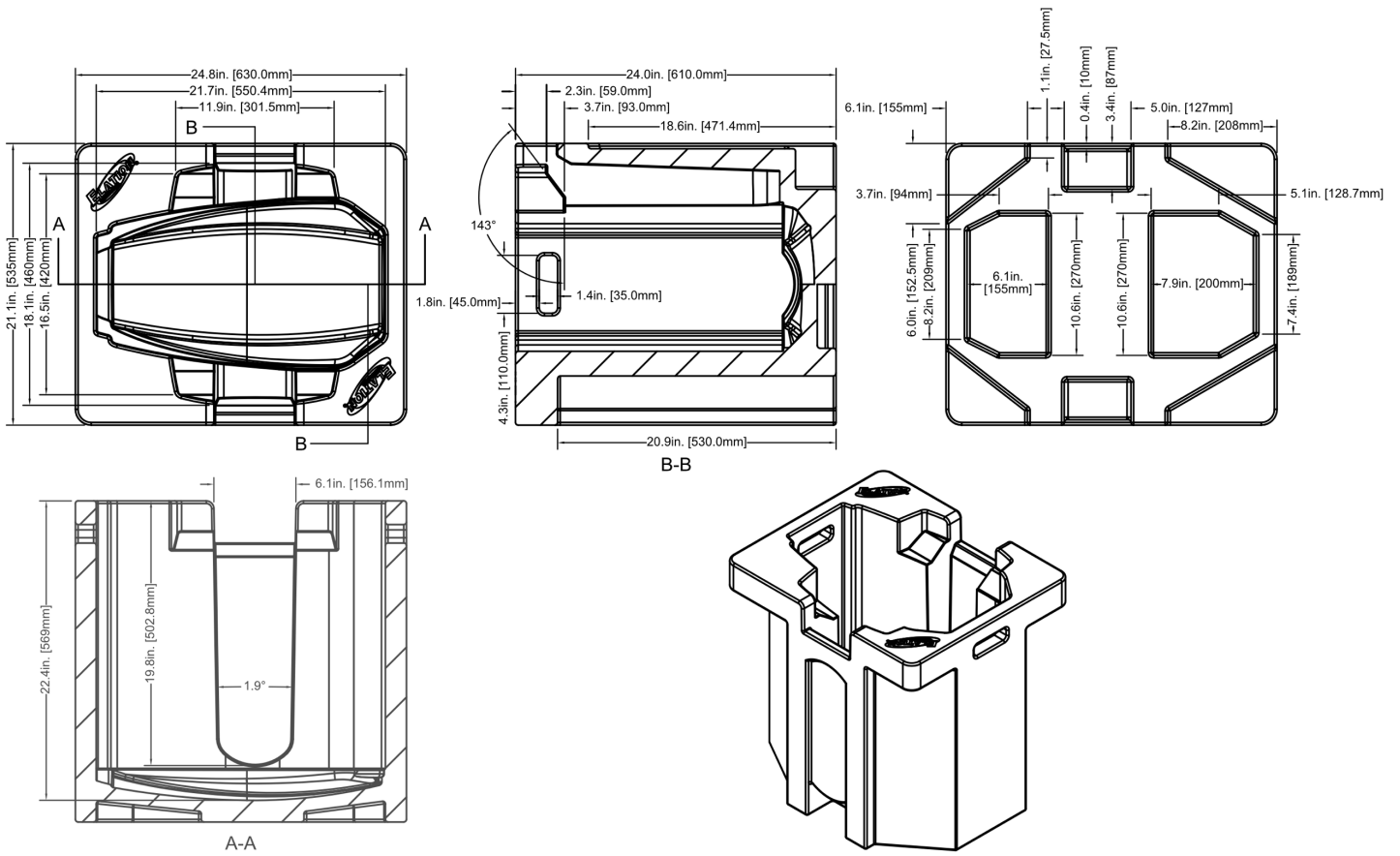

Specifications and improvements in the design of this unit and this manual are subject to change without any prior written notice.

# OPTIONAL ACCESSORIES

ORDER CODE	ITEM
TRIGGER CLAMP	Heavy Duty Wrap Around Hook Style Clamp
DRCPICASSO	Dual Split Road Case for ARTISTE PICASSO
EFL001	E-FLY™ External Wireless DMX Transceiver
AC5PDMX5PRO	5 ft. (1.5m) 5pin PRO DMX Cable
CAT6PRO5	5 ft. (1.5m) CAT6 Ethernet Cable
	Additional Cable Lengths Available

## FCC STATEMENT

This device complies with Part 15 of the FCC Rules. Operation is subject to the following two conditions: (1) this device may not cause harmful interference, and (2) this device must accept any interference received, including interference that may cause undesired operation.

## FCC RADIO FREQUENCY INTERFERENCE WARNINGS & INSTRUCTIONS

This product has been tested and found to comply with the limits as per Part 15 of the FCC Rules. These limits are designed to provide reasonable protection against harmful interference in a residential installation. This device uses and can radiate radio frequency energy and, if not installed and used in accordance with the included instructions, may cause harmful interference to radio communications. However, there is no guarantee that interference will not occur in a particular installation. If this device does cause harmful interference to radio or television reception, which can be determined by turning the device off and on, the user is encouraged to try to correct the interference by one or more of the following methods:

- Reorient or relocate the device.
- Increase the separation between the device and the receiver.
- Connect the device to an electrical outlet on a circuit different from which the radio receiver is connected.
- Consult the dealer or an experienced radio/TV technician for help.





