

ELATION[®]



KL SPOT IP
User Manual

©2023 **ELATION PROFESSIONAL** all rights reserved. Information, specifications, diagrams, images, and instructions herein are subject to change without notice. ELATION PROFESSIONAL logo and identifying product names and numbers herein are trademarks of ELATION PROFESSIONAL. Copyright protection claimed includes all forms and matters of copyrightable materials and information now allowed by statutory or judicial law or hereinafter granted. Product names used in this document may be trademarks or registered trademarks of their respective companies and are hereby acknowledged. All non-ELATION brands and product names are trademarks or registered trademarks of their respective companies.

ELATION PROFESSIONAL and all affiliated companies hereby disclaim any and all liabilities for property, equipment, building, and electrical damages, injuries to any persons, and direct or indirect economic loss associated with the use or reliance of any information contained within this document, and/or as a result of the improper, unsafe, insufficient and negligent assembly, installation, rigging, and operation of this product.

Elation Professional USA | 6122 S. Eastern Ave. | Los Angeles, CA. 90040

323-582-3322 | 323-832-9142 fax | www.elationlighting.com | info@elationlighting.com

Elation Professional B.V. | Junostraat 2 | 6468 EW Kerkrade, The Netherlands

+31 45 546 85 66 | +31 45 546 85 96 fax | www.elationlighting.eu | info@elationlighting.eu

Elation Professional Mexico | AV Santa Ana 30 | Parque Industrial Lerma, Lerma, Mexico 52000

+52 (728) 282-7070

DOCUMENT VERSION



Due to additional product features and/or enhancements, an updated version of this document may be available online. Please scan the QR Code with your mobile device or visit www.elationlighting.com for the latest revision/update of this manual, before installation and/or programming.

Date	Document Version	Software Version	DMX Channel Mode	Notes
08/21/23	1.0	1.02	24/32/22/28/22/28	Initial Release

CONTENTS

General Information	4
IP65 Rated	5
Limited Warranty (USA Only)	6
Safety Guidelines	7
Overview	9
Gobos & Gobo Wheels	10
Gobo Installation - Rotating Gobo Wheel	12
Gobo Dimensions	14
Framing Module Installation (Optional)	15
Torque Settings for Screws	16
Fan Modes and Low Noise Operation	17
Installation Guidelines	18
Remote Device Management (RDM)	22
System Menu/Service Port Update Instructions	23
Dimmer Modes & Curves	26
DMX Traits	27
DMX Traits - Framing Module	32
Colors Temperatures Chart	38
Virtual Swatch Book	39
Error Codes	40
Maintenance Guidelines	41
Specifications	42
Dimensional Drawings	43
Optional Accessories FCC Statement	44

GENERAL INFORMATION

INTRODUCTION

Please read and understand the instructions in this manual carefully and thoroughly before attempting to operate this device. These instructions contain important safety and use information. **This device is intended for use by trained personnel only, and is not suitable for private use.**

UNPACKING

Every device has been thoroughly tested and has been shipped in perfect operating condition. Carefully check the shipping carton for damage that may have occurred during shipping. If the carton is damaged, carefully inspect the device for damage, and be sure all accessories necessary to install and operate the device have arrived intact. In the event damage has been found or parts are missing, please contact our customer support team for further instructions. Please do not return this device to your dealer without first contacting customer support. Please do not discard the shipping carton in the trash. Please recycle whenever possible.

BOX CONTENTS

Power Cable (x1)

CUSTOMER SUPPORT

Contact ELATION Service for any product related service and support needs. Also visit forums.elationlighting.com with questions, comments, or suggestions.

ELATION SERVICE USA - Monday - Friday 8:00am to 4:30pm PST
323-582-3322 | Fax 323-832-9142 | support@elationlighting.com

ELATION SERVICE EUROPE - Monday - Friday 08:30 to 17:00 CET
+31 45 546 85 63 | Fax +31 45 546 85 96 | support@elationlighting.eu

REPLACEMENT PARTS please visit parts.elationlighting.com



IMPORTANT NOTICE!

THERE ARE NO USER SERVICEABLE PARTS INSIDE THIS UNIT. DO NOT ATTEMPT ANY REPAIRS YOURSELF; DOING SO WILL VOID YOUR MANUFACTURER'S WARRANTY. DAMAGES RESULTING FROM MODIFICATIONS TO THIS FIXTURE AND/OR THE DISREGARD OF SAFETY INSTRUCTIONS AND GUIDELINES IN THIS MANUAL VOID THE MANUFACTURER'S WARRANTY AND ARE NOT SUBJECT TO ANY WARRANTY CLAIMS AND/OR REPAIRS.

It is strongly recommended to power the fixture down completely when not in use. Doing so will reduce wear on the fixture due to sustained or extended operational periods, thereby maximizing its operational lifespan.

IP65 RATED

The **International Protection (IP)** rating system is commonly expressed as “**IP**” (Ingress Protection) followed by two numbers (i.e. IP65), where the numbers define the degree of protection. The first digit (Foreign Bodies Protection) indicates the extent of protection against particles entering the fixture, and the second digit (Water Protection) indicates the extent of protection against water entering the fixture. An **IP65** rated lighting fixture is designed and tested to protect against the ingress of dust (**6**), and low-pressure water jets from any direction (**5**).

NOTE: THIS FIXTURE IS INTENDED FOR TEMPORARY OUTDOOR USE ONLY!

Maritime/Coastal Environment Installations: A coastal environment is seaside adjacent, and caustic to electronics through exposure to atomized salt-water and humidity, whereas maritime is anywhere within 5-miles of a coastal environment.



NOT suitable for maritime/coastal environment installations. Installing this fixture in a maritime/coastal environment may cause corrosion and/or excessive wear to the interior and/or exterior components of the fixture. Damages and/or performance issues resulting from installation in a maritime/coastal environment will void the manufactures warranty, and will NOT be subject to any warranty claims and/or repairs.

Maritime installations require additional preparation, and additional service intervals may be needed given the maritime use. In general, IP ratings presuppose freshwater conditions VS maritime conditions, which are typically more “caustic” to IP fixtures (both internally and externally). A duty-cycle may also be needed when units are not in use. During times of high humidity and colder temperatures, condensation may occur internally so the fixture may require a duty-cycle to bring it up to running temperature, allowing any accumulation of moisture to be expelled via the vent valve. Recommendations can change based on installation environmental circumstances. A waterproof dome or similar device is recommended for use in permanent outdoor installations. When using a dome, refer to manufacturer recommendations for duty-cycle.

NOTE: NOT ALL FEATURES LISTED ARE AVAILABLE ON ALL FIXTURES; THE FOLLOWING INSTRUCTIONS MAY NOT APPLY. CONTACT SUPPORT FOR ADDITIONAL DETAILS.

Exterior Maintenance: Inspect the exterior every 30-days. The unit must be powered off/disconnected. The chassis should be inspected for any signs of contaminants. Inspect optics to determine if the lens is obstructed, then clean optics and chassis accordingly. Based on initial finding, schedule maintenance accordingly, keeping in mind that exterior maintenance will be required. Even if the luminaires are NOT in use, maintenance will still be needed given its location (exterior use). The use of a durable type of wax on the chassis is recommended since it will help prevent contaminant build up. Inspect both power and data lines for any signs of contaminants or corrosion. Periodically reapplying di-electric grease, especially in coastal environments. If any signs of corrosion/contaminants are present, clean thoroughly, and/or replace connectors, then reapply di-electric grease. Typically, this should be done annually, or any time an opportunity presents itself. As a preventive measure, annual replacement of both vent valves is recommended. The vent valve membrane can become contaminated and/or clogged causing improper venting of humidity within the luminaire. Inspect all mounting hardware as a precaution.

Interior Maintenance: Inspect the interior every 30-days. The unit must be powered off/disconnected.

- Inspect zoom/focus mechanism, clean optics, lubricate linear bearings (Krytox oil) as needed, inspect belts for wear
- Inspect all rotating effect wheels, manually rotate them, note any resistance
- Inspect all remaining rotating belts for any wear
- Inspect all fans, clean as needed, check rotation, check connections
- Inspect CMY module, manually move flags and check for signs of resistance, and if needed, clean guide rods first, then reapply a thin layer of grease (moly lube)
- Clean interior with low-volume compressed air, then clean optics prior to reassembly of head covers

Although the base has limited moving parts, the pan belt should also be inspected for wear. Remember to always perform an IP test anytime a cover is removed.

There is no specific time frame regarding the routine replacement of parts such as belts/stepper motors, PCBs, or LEDs. These items should only be replaced on an as needed bases, except for cooling fans, which should be replaced once the luminaries reach 10,000-hours. This is a prophylactic measure intended to keep the unit running as cool as possible, insuring proper function of all internal components. A complete service breakdown is available, please contact service@elationlighting.com for any needed parts or manuals.

LIMITED WARRANTY (USA ONLY)

- A. Elation Professional hereby warrants, to the original purchaser, Elation Professional products to be free of manufacturing defects in material and workmanship for a period of two years (730 days), and Elation Professional product rechargeable batteries to be free of manufacturing defects in material and workmanship for a period of six months (180 days), from the original date of purchase. This warranty excludes discharge lamps and all product accessories. This warranty shall be valid only if the product is purchased within the United States of America, including possessions and territories. It is the owner's responsibility to establish the date and place of purchase by acceptable evidence, at the time service is sought.
- B. For warranty service, send the product only to the Elation Professional factory. All shipping charges must be pre-paid. If the requested repairs or service (including parts replacement) are within the terms of this warranty, Elation Professional will pay return shipping charges only to a designated point within the United States. If any product is sent, it must be shipped in its original package and packaging material. No accessories should be shipped with the product. If any accessories are shipped with the product, Elation Professional shall have no liability what so ever for loss and/or damage to any such accessories, nor for the safe return thereof.
- C. This warranty is void if the product serial number and/or labels are altered or removed; if the product is modified in any manner which Elation Professional concludes, after inspection, affects the reliability of the product; if the product has been repaired or serviced by anyone other than the Elation Professional factory unless prior written authorization was issued to purchaser by Elation Professional; if the product is damaged because not properly maintained as set forth in the product instructions, guidelines and/or user manual.
- D. This is not a service contract, and this warranty does not include any maintenance, cleaning or periodic check-up. During the periods as specified above, Elation Professional will replace defective parts at its expense, and will absorb all expenses for warranty service and repair labor by reason of defects in material or workmanship. The sole responsibility of Elation Professional under this warranty shall be limited to the repair of the product, or replacement thereof, including parts, at the sole discretion of Elation Professional. All products covered by this warranty were manufactured after January 1, 1990, and bare identifying marks to that effect.
- E. Elation Professional reserves the right to make changes in design and/or performance improvements upon its products without any obligation to include these changes in any products theretofore manufactured.
- F. No warranty, whether expressed or implied, is given or made with respect to any accessory supplied with the products described above. Except to the extent prohibited by applicable law, all implied warranties made by Elation Professional in connection with this product, including warranties of merchantability or fitness, are limited in duration to the warranty periods set forth above. And no warranties, whether expressed or implied, including warranties of merchantability or fitness, shall apply to this product after said periods have expired. The consumer's and/or dealer's sole remedy shall be such repair or replacement as is expressly provided above; and under no circumstances shall Elation Professional be liable for any loss and/or damage, direct and/or consequential, arising out of the use of, and/or the inability to use, this product.
- G. This warranty is the only written warranty applicable to Elation Professional products and supersedes all prior warranties and written descriptions of warranty terms and conditions heretofore published.

WARRANTY RETURNS

All returned service items whether under warranty or not, must be freight pre-paid and accompany a return authorization (R.A.) number. The R.A. number must be clearly written on the outside of the return package. A brief description of the problem as well as the R.A. number must also be written down on a piece of paper and included in the shipping container. If the unit is under warranty, you must provide a copy of your proof of purchase invoice. Items returned without a R.A. number clearly marked on the outside of the package will be refused and returned at customer's expense. You may obtain a R.A. number by contacting customer support.

SAFETY GUIDELINES

This fixture is a sophisticated piece of electronic equipment. To guarantee smooth operation, it is important to follow all instructions and guidelines in this manual. Elation Professional is not responsible for injury and/or damages resulting from the misuse of this fixture due to the disregard of the information printed in this manual. Only qualified and/or certified personnel should perform installation of this fixture and only the original rigging parts included with this fixture should be used for installation. Any modifications to the fixture and/or the included mounting hardware will void the original manufacturer's warranty and increase the risk of damage and/or personal injury.



PROTECTION CLASS 1 - FIXTURE MUST BE PROPERLY GROUNDED.



THERE ARE NO USER SERVICEABLE PARTS INSIDE THIS UNIT. DO NOT ATTEMPT ANY REPAIRS YOURSELF. DOING SO WILL VOID YOUR MANUFACTURER'S WARRANTY. DAMAGES RESULTING FROM MODIFICATIONS TO THIS DEVICE AND/OR THE DISREGARD OF SAFETY INSTRUCTIONS AND GUIDELINES IN THIS MANUAL VOID THE MANUFACTURER'S WARRANTY AND ARE NOT SUBJECT TO ANY WARRANTY CLAIMS AND/OR REPAIRS.



**DO NOT PLUG THIS UNIT INTO A DIMMER PACK
DO NOT REMOVE THE COVER UNDER ANY CONDITIONS
NEVER OPERATE THIS UNIT WITH THE CASING REMOVED
UNPLUG FROM POWER DURING LONG PERIODS OF NON-USE
DISCONNECT POWER BEFORE PERFORMING MAINTENANCE**

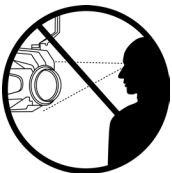

**NEVER LOOK DIRECTLY INTO THE LIGHT SOURCE!
RETINA INJURY RISK - MAY INDUCE BLINDNESS!
SENSITIVE PERSONS MAY SUFFER AN EPILEPTIC SHOCK!**



**FIXTURE SHOULD BE PLACED A MINIMUM OF 1.0 FOOT (0.3 METERS) FROM ANY NEARLY OBJECTS OR SURFACES.
FIXTURE SHOULD BE PLACED A MINIMUM OF 1.6 FEET (0.5 METERS) FROM ANY FLAMMABLE MATERIALS.
MAXIMUM AMBIENT OPERATING TEMPERATURE IS 113°F (45°C)**

SAFETY GUIDELINES

For Your Own Personal Safety, Please Read and Understand This Manual Completely Before You Attempt To Install Or Operate This Unit!

- Do not touch the fixture housing during operation, as it may be hot.
- Do not shake the fixture, and avoid using brute force when installing and/or operating.
- Use only the original packaging and materials to transport or ship the fixture for service. Make sure to retain the original packaging for this purpose.
- Be sure that the local power outlet matches the required voltage for the device.
- Do not open up the device for any reason. There are no user serviceable parts inside.
- Disconnect the device's main power when left unused for long periods of time.
- Never connect this device to a dimmer pack.
- Do not attempt to operate this device if it has been damaged in any way.
- Never operate this device with the cover removed.
- Do not attempt to operate this device if the power cord has been frayed or broken.
- Never force a power cord connector into the fixture. If the power cord or any of its connectors are damaged, replace immediately with a new cord of the same power rating.
- Do not attempt to remove or break off the ground prong from the electrical cord. This prong is used to reduce the risk of electrical shock and fire in case of an internal short.
- Only handle the power cord by the plug end. Never disconnect the plug by tugging on the wire portion of the power cord.
- Disconnect from main power before making any type of connection.
- Never block the air ventilation slots. Always be sure to mount this device in an area that will allow proper ventilation. Allow about 6" (15cm) between this device and a wall.
- Always mount this unit in a safe and stable matter.
- Please route your power cord out of the way of foot traffic. Power cords should be routed so they are not likely to be walked on or pinched by items placed upon or against them.
- Before performing any servicing, turn off and disconnect the device from power and allow at least 15 minutes for the device to cool.
- Consistent operational breaks will ensure that this fixture will function properly for many years.
- The device should be serviced by qualified service personnel when:
 - A. The power-supply cord or the plug has been damaged.
 - B. Objects have fallen on, or liquid has been spilled into, the device.
 - C. The device has been immersed in liquid or exposed to moisture.
 - D. The appliance does not appear to operate normally or exhibits a marked change in performance.

Keep all flammable materials away from this fixture!

OVERVIEW

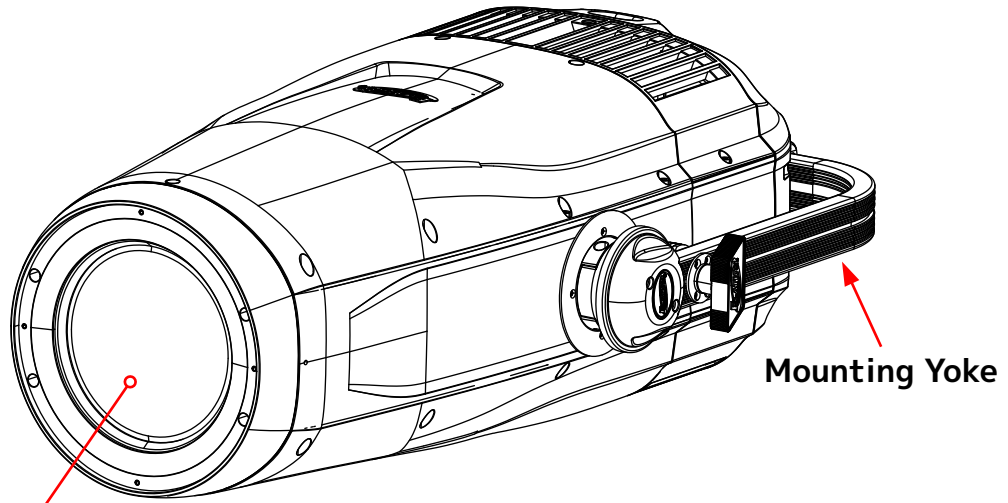

Lens

Mounting Yoke

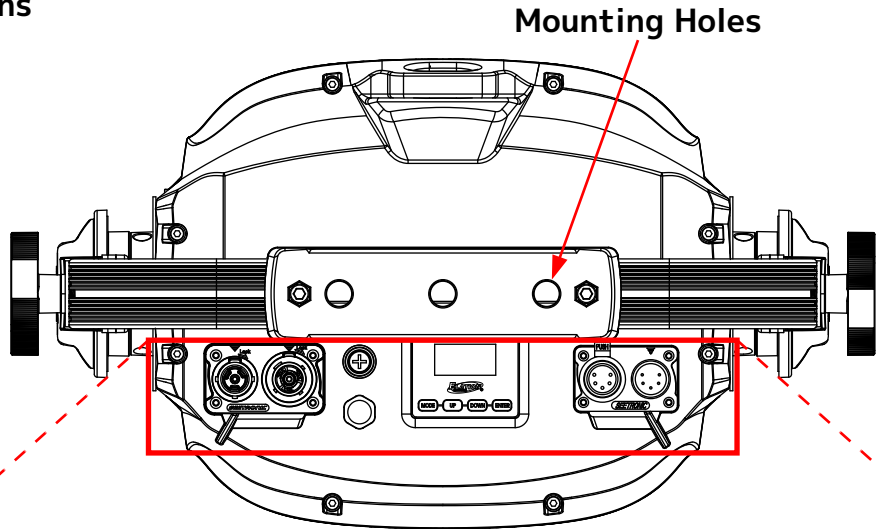

Mounting Holes

Fuse: T5A/250V

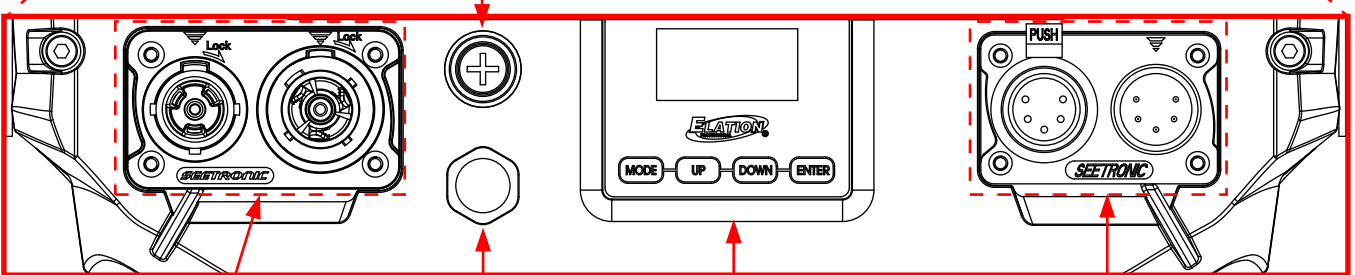

IP65 Locking Power In/Out

Valve

Control Panel

IP65 5pin DMX In/Out

GOBOS & GOBO WHEELS

ROTATING GOBO WHEEL



Pos. 1



Pos. 2

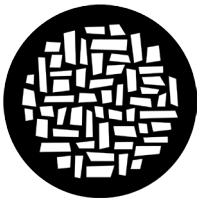

Pos. 3

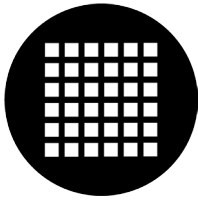

Pos. 4

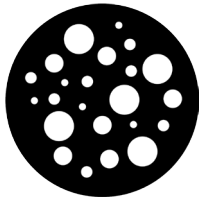

Pos. 5

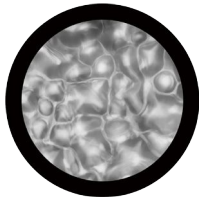

Pos. 6

FIXED GOBO WHEEL



Pos. 1



Pos. 2

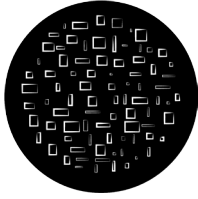

Pos. 3

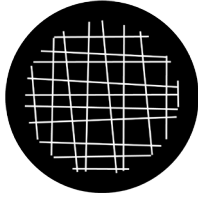

Pos. 4

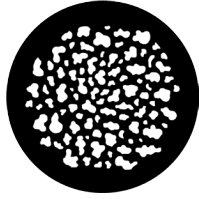

Pos. 5



Pos. 6



Pos. 7

BI-DIRECTIONAL ANIMATION WHEEL

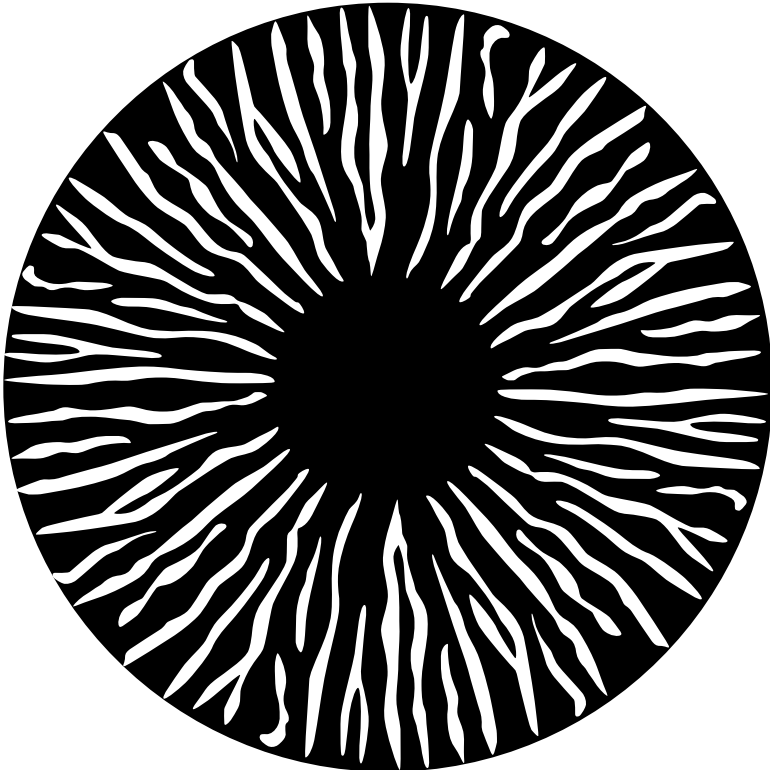

GOBOS & GOBO WHEELS

Rotating Gobo Wheel

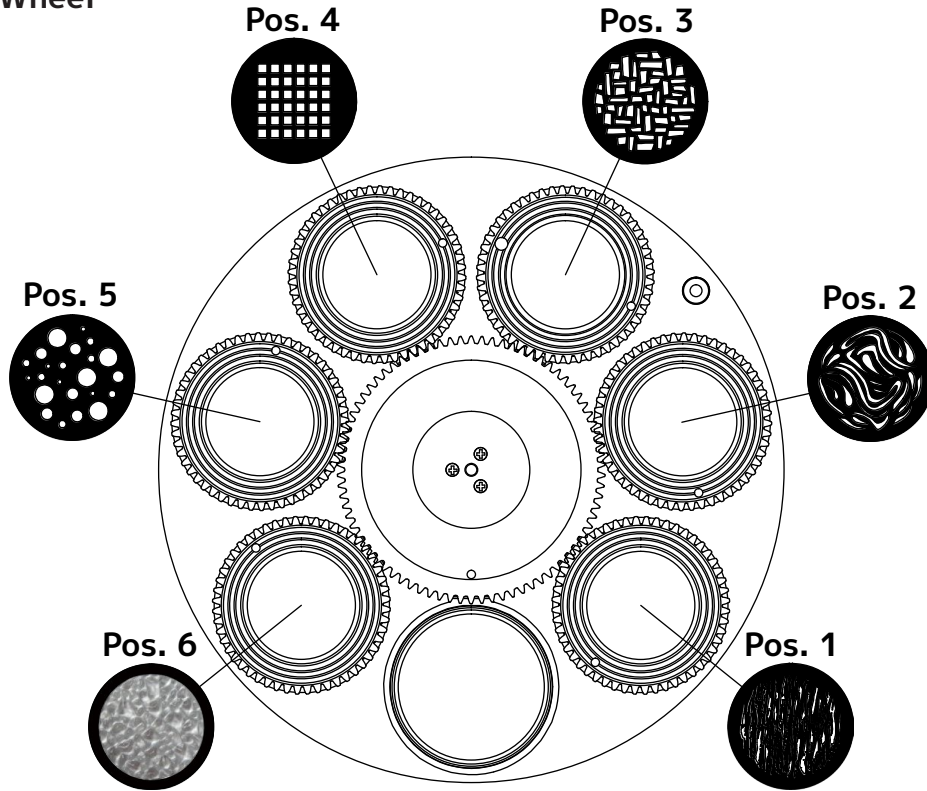

Fixed Gobo Wheel

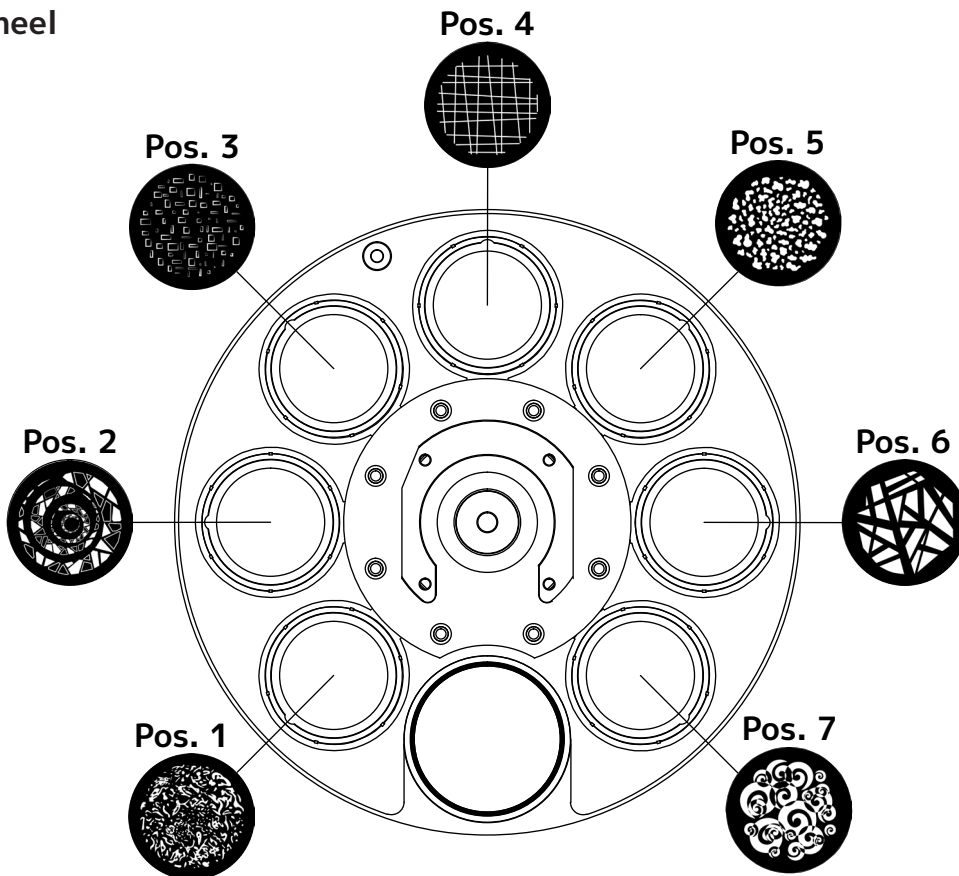

GOBO INSTALLATION - ROTATING GOBO WHEEL

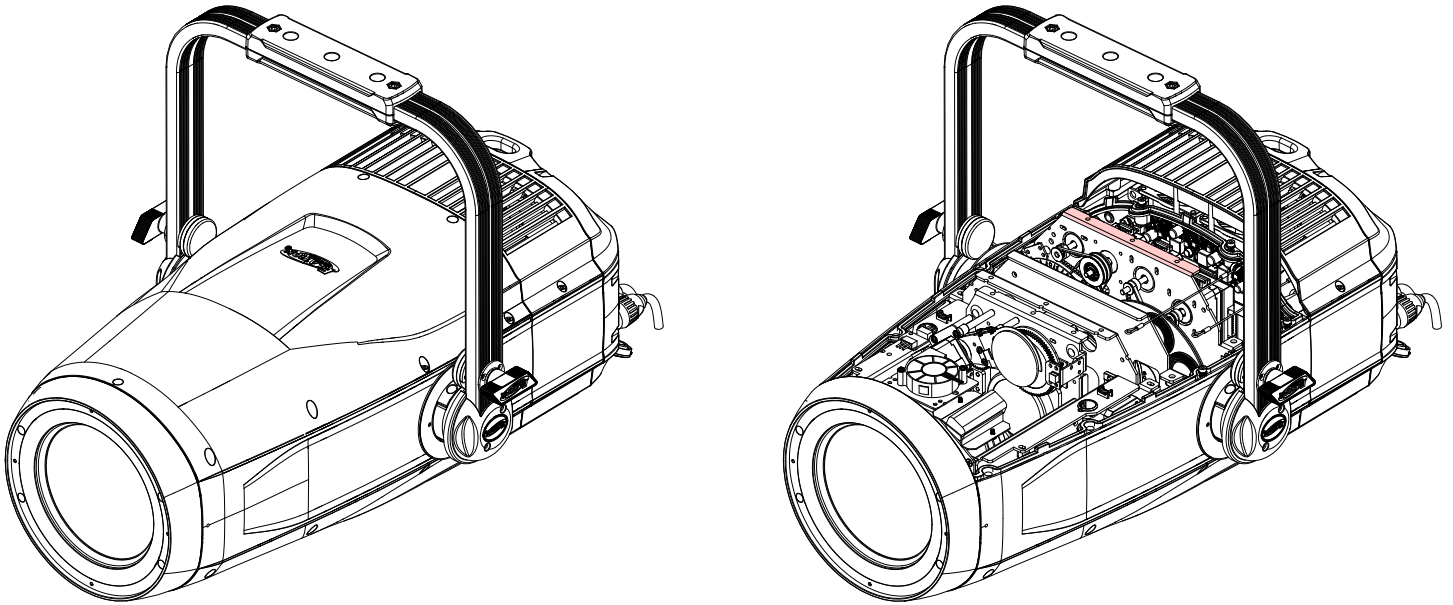

Open the top cover of the fixture and locate the rotating gobo wheel module.

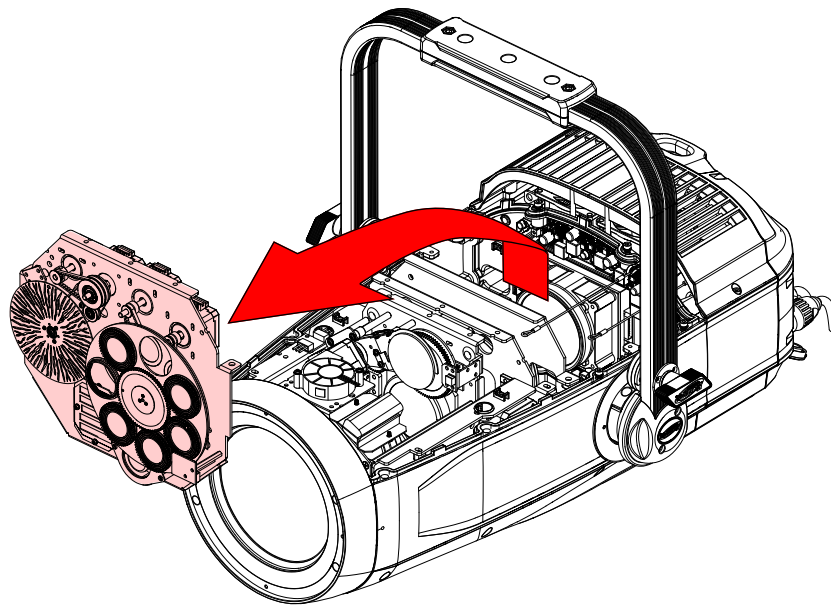

Remove the screws that secure it to the internal housing frame, then carefully remove it and set it aside.

GOBO INSTALLATION - ROTATING GOBO WHEEL

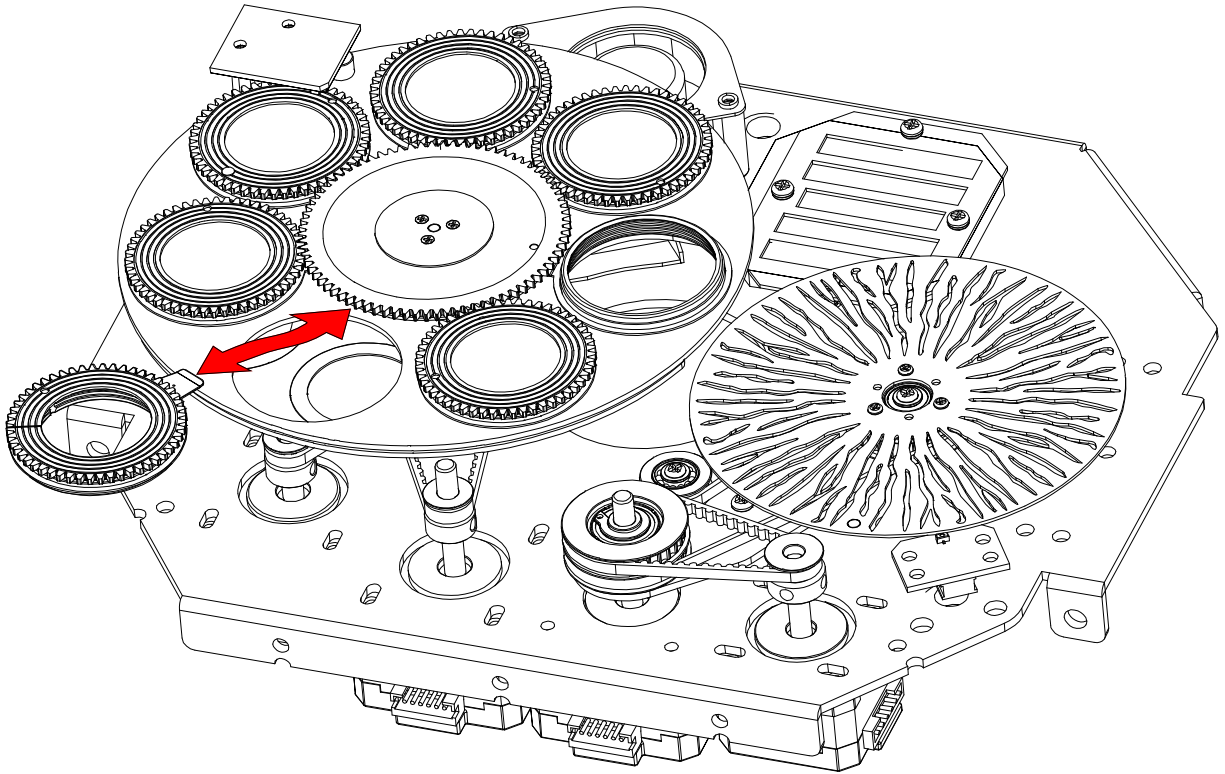

Locate the Rotating GOBO being replaced. Carefully press the GOBO Holder up to clear the frame, then pull it out and away until it fully clears the Fixed GOBO Wheel.

Locate the tab of the Retention Spring, and with a precision pick (or similar tool), carefully press the Retaining Spring inward to relieve the tension. Remove the retaining spring and carefully separate the GOBO from the GOBO Holder.

CAUTION: TAKE CARE NOT TO SCRATCH GOBO OR GOBO HOLDER

To ensure proper Gobo orientation on the Rotating Gobo Wheel, align the Alignment Dots before installing the Retention Spring. These alignment dots are the notch in the Gobo Holder, the dot on the top and bottom of the Gobo Holder Retention Tab, and on the Gobo itself.

Rotate the Gear of the Rotating Gobo Wheel until the Gear Alignment Dot on the Rotating Gobo Wheel is lined up with the empty Gobo Holder Slot. Install the Gobo Holder Tab into the Gobo Holder Tab Receptacle and press until the Gobo Holder gently springs into the empty Gobo Holder Slot.

GOBO DIMENSIONS

Custom Gobos

Rotating Gobo Wheel Positions 1-5 & Fixed Gobo Wheel Positions 1-7

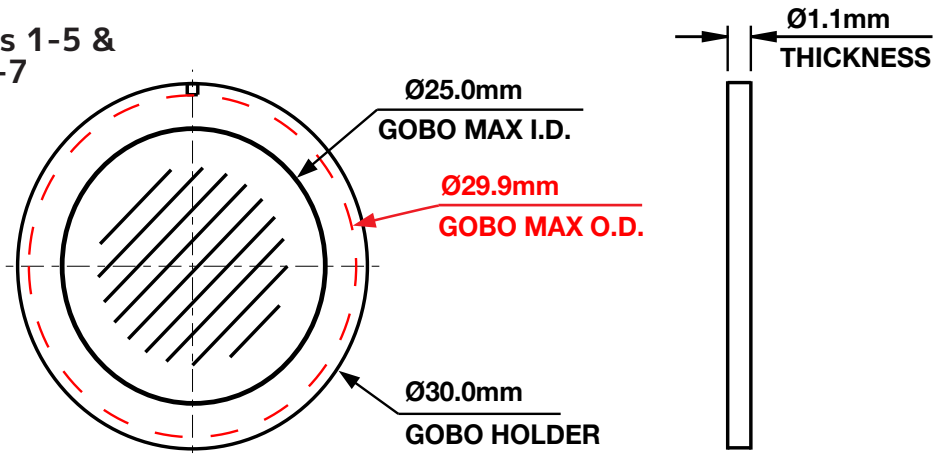

Rotating Gobo Wheel Position 6

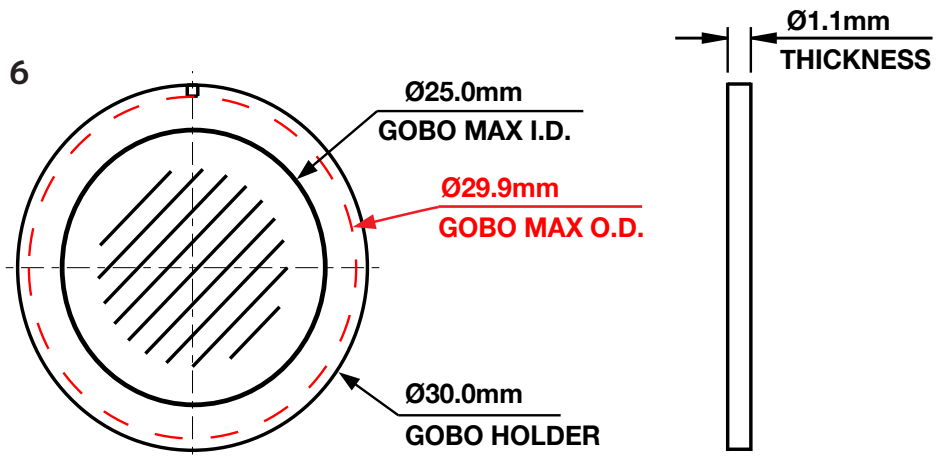

KL SPOT IP ROTATING GLASS GOBOS WHEEL 1+2	
Gobo O.D. (Max. Outer Diameter)	φ29.9mm
Gobo I.D. (Max. Image Diameter)	φ25.0mm
Gobo Holder Diameter	φ30.0mm
Gobo Thickness	1.1mm
Gobo Thickness Rotating Gobo Wheel Pos 6.	2.5mm
Gobo Material	High Temp Glass (Max 600C°)

Please be aware of the intended position and correct sizing requirements of custom gobos.

IMPORTANT NOTICE REGARDING CUSTOM GOBOS

Due to the high temperature optical system, special glass material is required for custom gobos, and due to varying manufacturing processes and tolerances, it is highly recommended that a gobo sample and holder from the fixture be provided to the custom gobo vendor for accurate sizing. Extended testing of custom gobo designs is highly recommended prior to use. Contact ELATION SERVICE for further information:

ELATION SERVICE USA -Monday -Friday 8:00am to 4:30pm PST
323-582-3322 | Fax 323-832-9142 | support@elationlighting.com

ELATION SERVICE EUROPE -Monday -Friday 08:30 to 17:00 CET
+31 45 546 85 63 | Fax +31 45 54685 96 | support@elationlighting.eu

FRAMING MODULE INSTALLATION

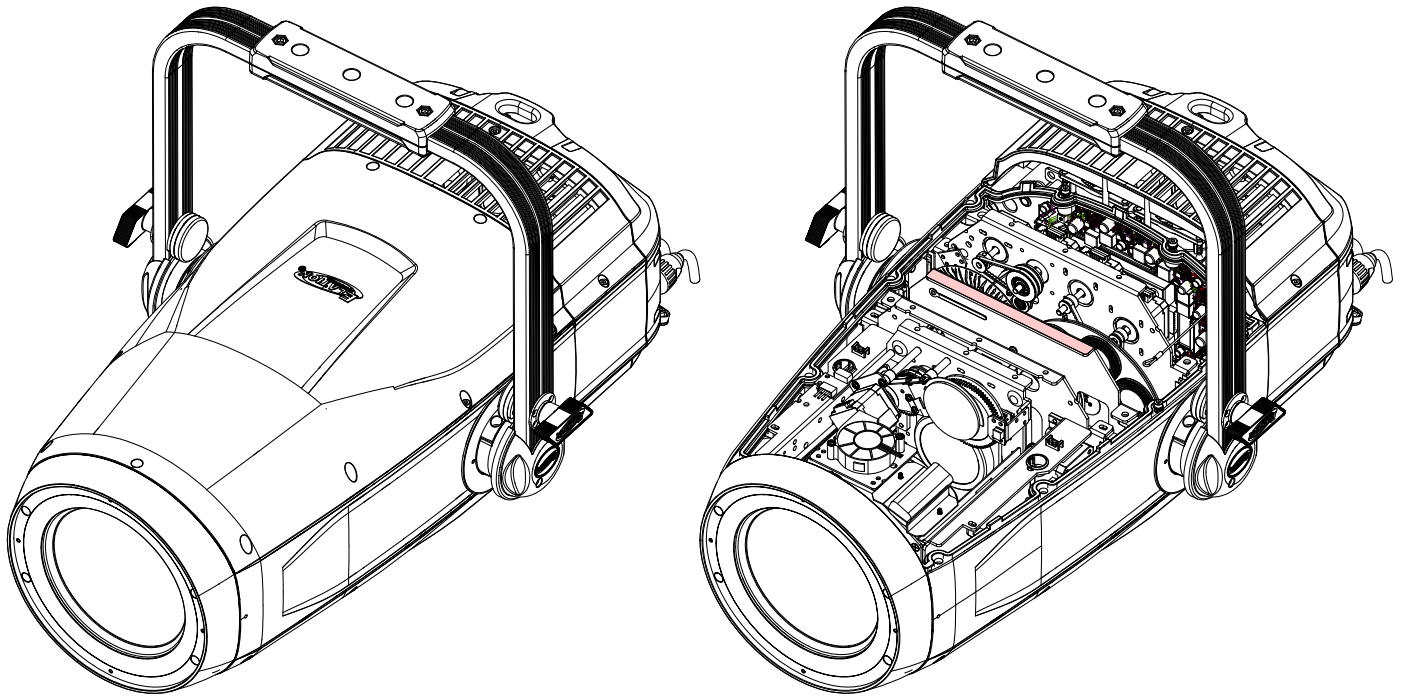

Open the top cover of the fixture and locate the framing module placeholder.

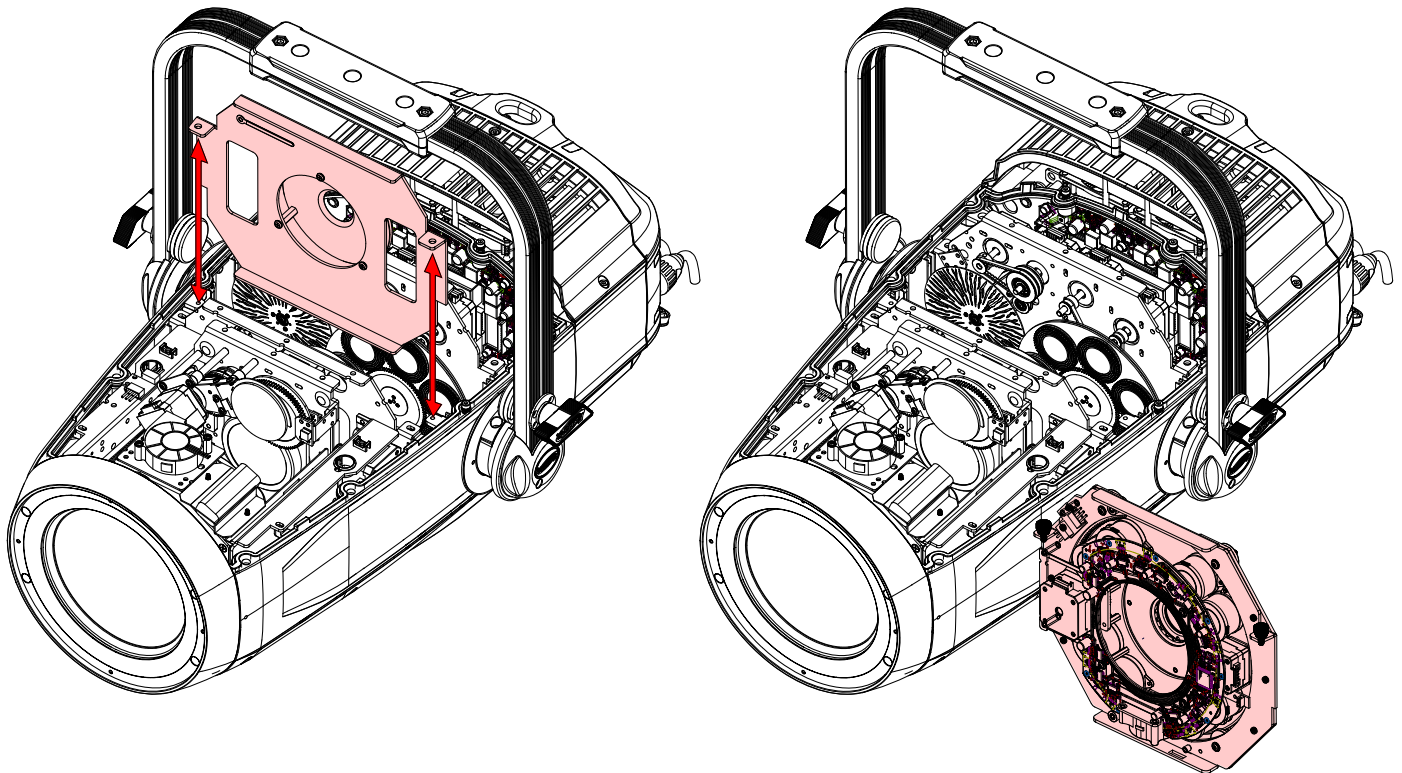

Remove the framing module placeholder and replace it with the new framing module, then reinstall the top cover.

TORQUE SETTINGS FOR SCREWS

The hex-head screws holding either the panels or the base **MUST** be tightened with a torque wrench (not included).

TORQUE SETTINGS:

lbf-in = Pound Force Inches

kgf-cm = Kilogram Force Centimeters



CAUTION! THE USE OF PROTECTIVE GLOVES AND SAFETY GOGGLES IS STRONGLY RECOMMENDED WHILE PERFORMING THE IP PRESSURE TEST! AVOID PLACING YOUR FACE, EYES, HANDS, ETC IN CLOSE PROXIMITY TO THE FIXTURE'S LENS WHILE PERFORMING THE TEST!



CAUTION! DO NOT OVER TORQUE SCREWS AS THIS CAN CAUSE LEAKAGE ISSUES!

Fix Head Front Cover
(10±0.5/Kgf.cm)

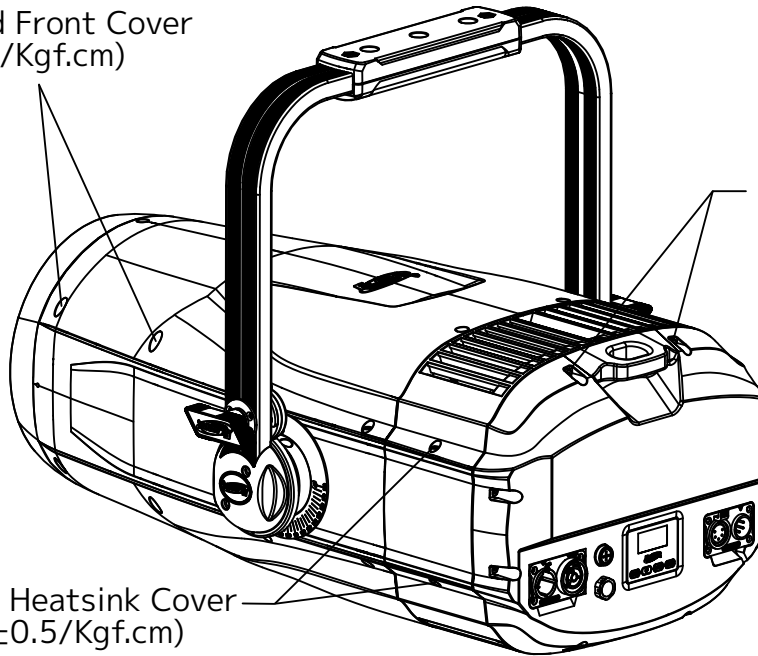

Fix Head Back Cover
(10±0.5/Kgf.cm)

Fix Heatsink Cover
(5±0.5/Kgf.cm)

TO CONFIRM THE IP65 INTEGRITY AFTER OPENING COVER, TEST FIXTURE USING THE ELATION IP TESTER. CONTACT ELATION SERVICE FOR MORE DETAILS.



IP PRESSURE TESTING PARAMETERS	
Parameter	Value
Maximum Pressure	2.3psi (23.0 KPa)
Minimum Pressure	2.9psi (20.0 KPa)
Inflation Time	30-seconds
Balance Time	15-seconds
Detection Time	15-seconds
Leakage amount	>100Pa

FAN CONTROL AND LOW NOISE OPERATION

The KL Spot IP is a high-performance fixture suited for multiple applications. For noise critical environments such as Theater, Opera, or Orchestral Halls, it offers various fan operation modes which remove unwanted noise distractions for the audience and performers. Fan Modes can be changed remotely via the DMX control channel, allowing the fixture to offer high output or whisper-silent operation at a moment's notice. All Fan Modes smoothly transition over a brief period, preventing unwanted attraction to the fixture.

Auto (Default) – Fans only run at the speeds needed to keep the LED engine within a safe temperature range, and ensures optimal performance of the fixture. They will turn off if possible; for example, when the fixture is dimmed to a low intensity. Fans sense the ambient and fixture temperature and will, at all times, try to keep noise levels at a minimum. The fixture output will only be reduced when the LED engine cannot be cooled to its safe operating range due to a high ambient temperature.

NOTE: This mode is recommended for daily operation.

High – Fan speeds are increased throughout the fixture for the most efficient cooling. This mode will increase wear on the fans and should only be utilized in exceptional circumstances. Fans will always run, even if the fixture is dimmed. Fixture output is kept at 100% unless the LED engine temperature reaches an unsafe temperature, at which point the fixture will reduce power carefully to ensure continued safe operation. This mode is only required in very high ambient temperatures when automatic fan speed adjustments are not desired.

Low - For very critical noise environments, the fixture offers this mode, and two additional Low Noise Modes for silent operation: Studio and Mute. In Low mode, the fixture output will be reduced, yet due to the extremely high luminous flux, the fixture still offers outstanding performance. In Low Noise Mode, all parameters of the fixture operate more quietly with reduced fan speeds.

Studio – Fan speeds are reduced throughout the fixture for a lower noise profile. This mode should be sufficient for most uses where lower noise is required.

INSTALLATION GUIDELINES



FLAMMABLE MATERIAL WARNING

Keep fixture minimum 5.0 feet (1.5m) away from flammable materials and/or pyrotechnics.



ELECTRICAL CONNECTIONS

A qualified electrician should be used for all electrical connections and/or installations.



MINIMUM DISTANCE TO OBJECTS/SURFACES IS 1 FOOT (0.3 METERS)



MINIMUM DISTANCE OF FLAMMABLE MATERIALS FROM THE SURFACE IS 1.6 FEET (0.5 METER)



MAXIMUM AMBIENT TEMPERATURE 113° F (45°C)



DO NOT INSTALL THE FIXTURE IF YOU ARE NOT QUALIFIED TO DO SO!

Fixture **MUST** be installed following all local, national, and country commercial electrical and construction codes and regulations.

Before rigging/mounting a single fixture or multiple fixtures to any metal truss/structure or placing the fixture(s) on any surface, a professional equipment installer **MUST** be consulted to determine if the metal truss/structure or surface is properly certified to safely hold the combined weight of the fixture(s), clamps, cables, and accessories.

Fixture(s) should be installed in areas outside walking paths, seating areas, or away from areas where unauthorized personnel might reach the fixture by hand.

NEVER stand directly below the fixture(s) when rigging, removing, or servicing.

Overhead fixture installation must always be secured with a secondary safety attachment, such as an appropriately rated safety cable.

Allow approximately 15 minutes for the fixture to cool down before servicing.

INSTALLATION GUIDELINES

CLAMP INSTALLATION

This device features mounting clamp attachment point built into the mounting bracket, as well as a safety cable attachment point located on the fixture (see the illustration below). When mounting the fixture to a truss or any other suspended or overhead installation, be sure to secure an appropriately rated clamp (not included) to the clamp attachment point and attach a separate SAFETY CABLE of the appropriate safety rating to the safety cable rigging point.

The KL Spot IP has a thicker 30mm yoke to provide greater positional stability to the fixture. However, because of this increased thickness, the bolts usually provided for most theatrical clamps are not long enough to provide sufficient threads to securely attach a washer and locking nut. The clamp manufacturer may recommend appropriate bolt options.

For most trigger clamps, a bolt length of 60mm is recommended.

It is crucial to acknowledge that all decisions concerning rigging and the methods employed for mechanically fastening the fixture to temporary or permanent structures rest with the user. Consult a qualified structural engineer if necessary.

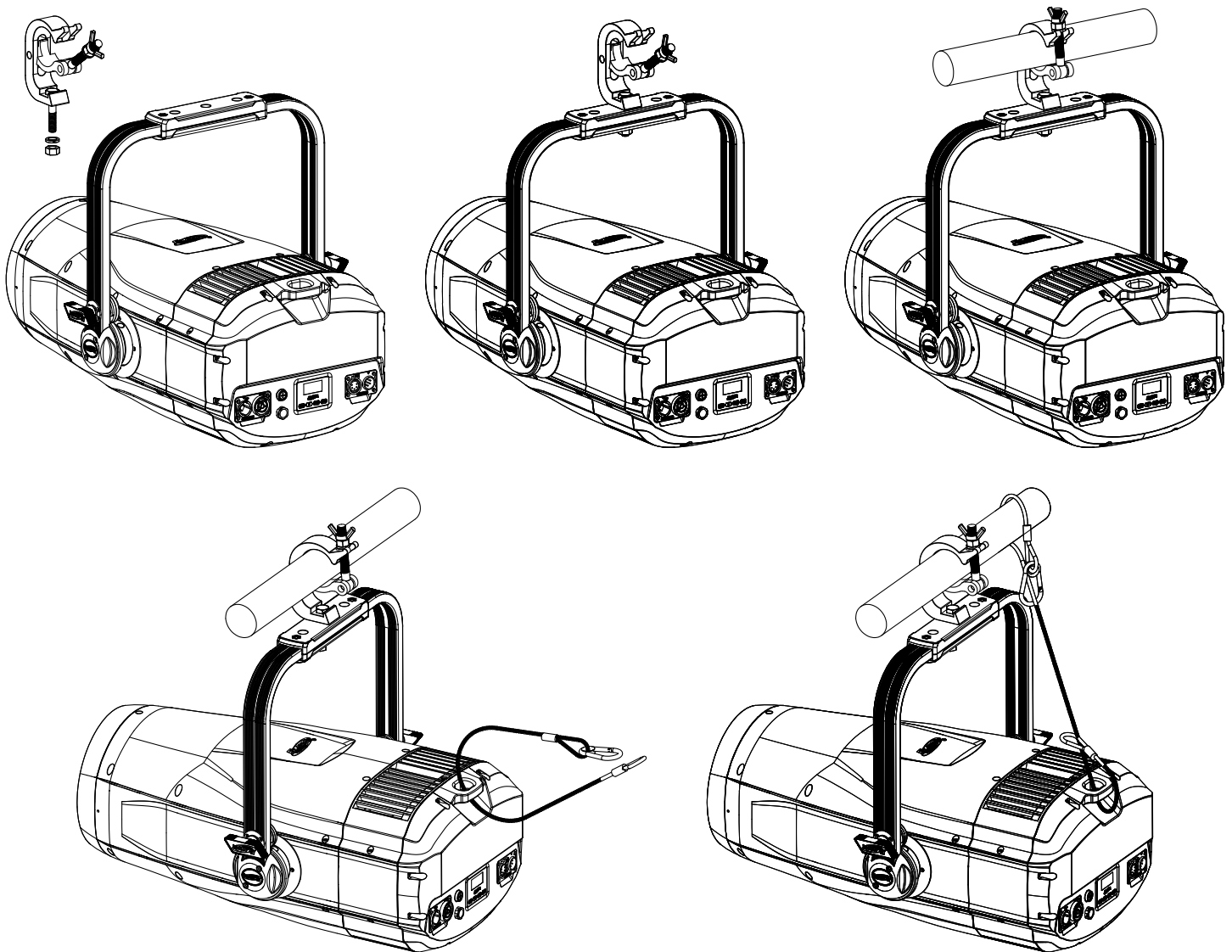

INSTALLATION GUIDELINES

RIGGING

Overhead rigging requires extensive experience, including but not limited to: calculating working load limits, understanding the installation material being used, and periodic safety inspection of all installation material and the fixture itself. If you lack these qualifications, do not attempt to perform the installation yourself. Improper installation can result in bodily injury.

FIXTURE INSTALLATION

The Elation KL SPOT IP is fully operational in three different mounting positions, hanging upside-down, mounted sideways on trussing, or set on a flat level surface. Be sure this fixture is kept at least 0.2m (7.9in.) away from any flammable materials (decoration etc.). Always use and install the supplied safety cable as a safety measure to prevent accidental damage and/or injury in the event the clamp fails. Never use the carrying handles for secondary attachment.

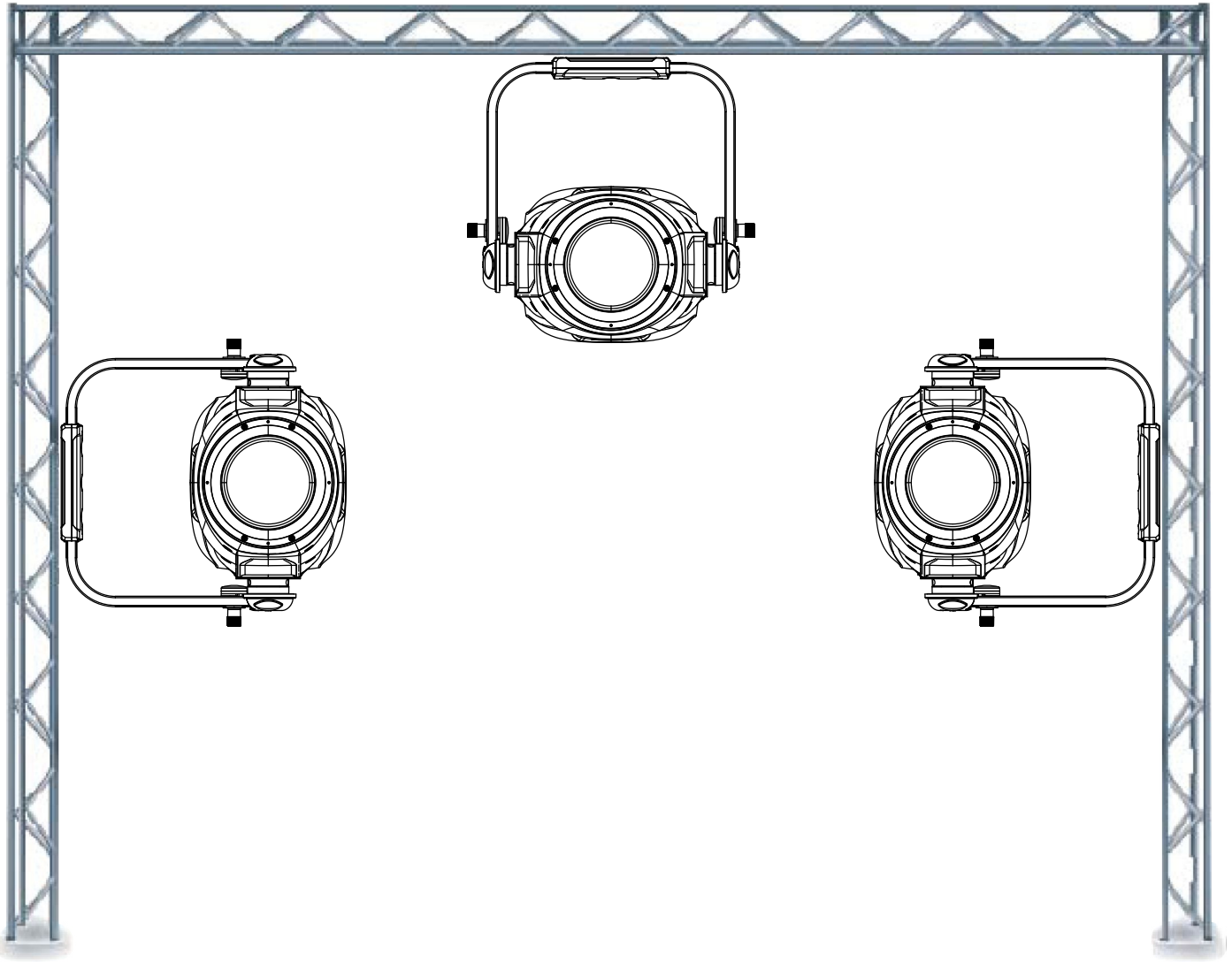

FALLING FIXTURES CAN CAUSE SEVERE INJURY OR SERIOUS EQUIPMENT DAMAGE! FOR THIS REASON, FIXTURES SHOULD BE INSTALLED AND INSPECTED ONLY BY QUALIFIED PERSONNEL. DO NOT INSTALL THE UNIT IF YOU LACK THE QUALIFICATIONS TO DO SO, OR IF YOU HAVE DOUBTS ABOUT THE SAFETY AND SECURITY OF THE INSTALLATION SETUP OR LOCATION!



ALWAYS ATTACH A SAFETY CABLE WHENEVER INSTALLING THIS FIXTURE IN A SUSPENDED ENVIRONMENT TO ENSURE THE FIXTURE WILL NOT FALL IF THE CLAMP FAILS.

INSTALLATION GUIDELINES

POTENTIAL INTERNAL FIXTURE DAMAGE FROM EXTERNAL SOURCES OF LIGHT BEAMS

External sources of light beams from direct sunlight, lighting moving head fixtures, and lasers, which are focused directly towards the exterior housing and/or penetrate the front lens opening of ELATION lighting fixtures, can cause severe internal damage including burning to optics, dichroic color filters, glass and metal gobos, prisms, animation wheels, frost filters, iris, shutters, motors, belts, wiring, discharge lamps, and LEDs.

This issue is not specific only to ELATION lighting fixtures, it is a common issue with lighting fixtures from all manufacturers. Although there is no true way to fully prevent this issue from happening, the guidelines below can prevent any potential damage from occurring if followed. Contact ELATION Service for more details.

DO NOT EXPOSE THE FIXTURE AND/OR FRONT LENS OPENING TO LIGHT BEAMS FROM DIRECT SUNLIGHT, OTHER LIGHTING MOVING HEAD FIXTURES, AND LASERS WHILE UNPACKING, INSTALLATION, USE, AND EXTENDED IDLE TIMES OUTDOORS. DO NOT FOCUS A LIGHT BEAM FROM ONE LIGHTING FIXTURE DIRECTLY TOWARDS ANOTHER.

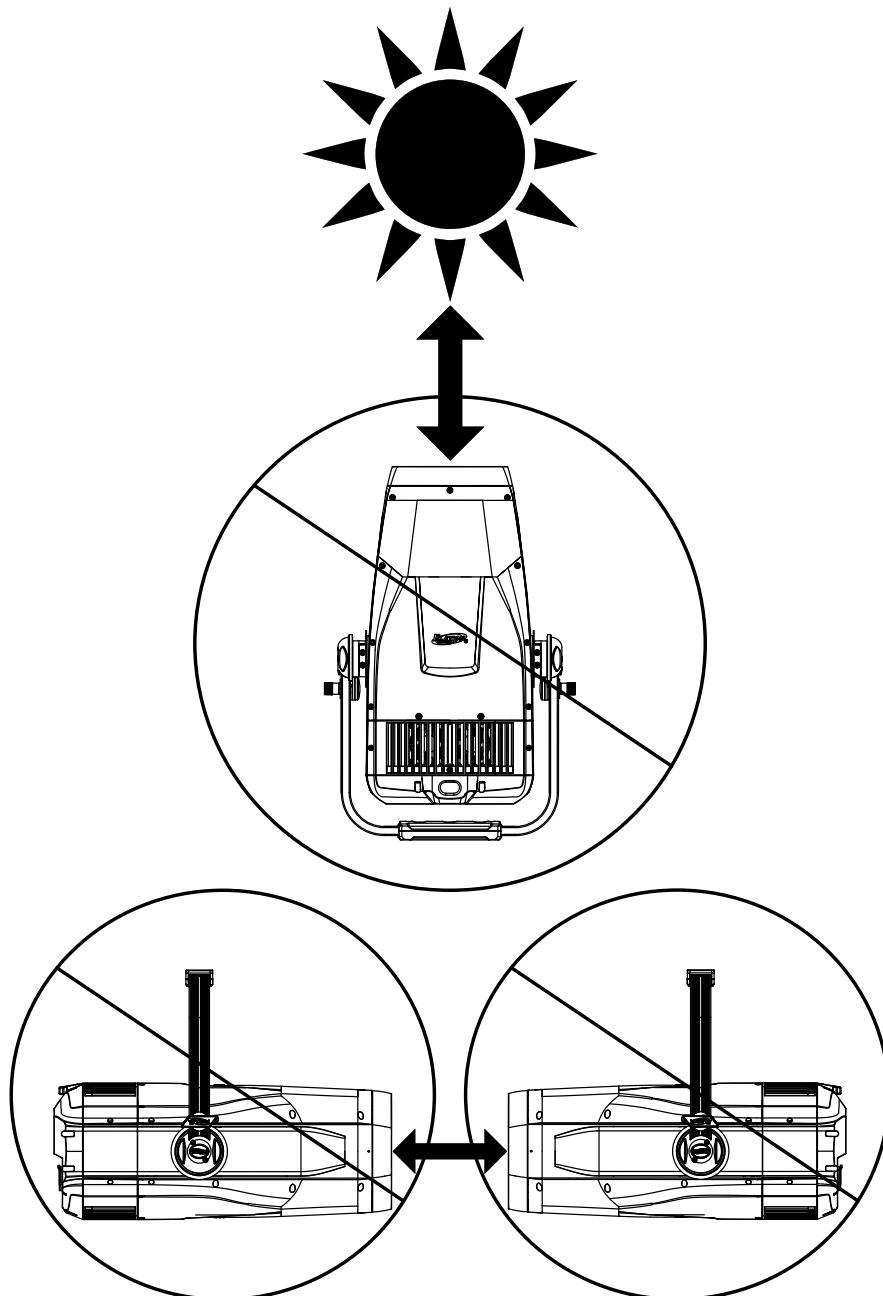

REMOTE DEVICE MANAGEMENT (RDM)

NOTE: In order for RDM to work properly, RDM enabled equipment must be used throughout the entire system, including DMX data splitters and wireless systems.

Remote Device Management (RDM) is a protocol that sits on top of the DMX512 data standard for lighting, allowing the DMX systems of the fixtures to be modified and monitored remotely. This protocol is ideal for instances in which a unit is installed in a location that is not easily accessible.

With RDM, the DMX512 system becomes bi-directional, allowing a compatible RDM enabled controller to send out a signal to devices on the wire, as well as allowing the fixture to respond (known as a GET command). The controller can then use its SET command to modify settings that would typically have to be changed or viewed directly via the unit's display screen, including the DMX Address, DMX Channel Mode, and Temperature Sensors.

FIXTURE RDM INFORMATION:

RDM Code	Device ID	Device Model ID	Personality ID
0x22A6	002A	42	001 Standard 002 Extended 003 RGB 004 RGB Extended 005 CMY 006 CMY Extended

Please be aware that not all RDM devices support all RDM features, and therefore it is important to check beforehand to ensure that the equipment that you are considering includes all of the features that you require.

The following parameters are available on this device:

[0x0080] Device Model Description	[0x0032] Clear Status ID
[0x0081] Manufacturer Label	[0x0120] Slot Information
[0x0082] Device Label	[0x0121] Slot Description
[0x0070] Product Detail ID List	[0x0122] Default Slot Value
[0x00E0] DMX Personality	[0x0200] Sensor Definition
[0x00E1] DMX Personality Description	[0x0201] Sensor Value
[0x0400] Device Hours	[0x0500] Display Invert
[0x0405] Device Power Cycles	[0x0501] Display Level
[0x00C2] Boot Software Version Label	[0x0603] Realtime Clock
[0x00C1] Boot Software Version ID	[0x1010] Power State
[0x00A0] Language Capabilities	[0x1031] Preset Playback
[0x00B0] Language	
[0x0015] Comms Status	
[0x0030] Status Messages	
[0x0031] Status ID Description	

SYSTEM MENU

The fixture includes an easy to navigate system menu. The control panel display is located on the rear panel of the fixture (see image below) and provides access to the main system menu, where all necessary system adjustments are made to the fixture. During normal operation, pressing the MODE button once will access the fixture's main menu. Once in the main menu you can navigate through the different functions and access the sub-menus with the DOWN and UP buttons. Once you reach a field that requires adjusting, press the ENTER button to activate that field and use the DOWN and UP buttons to adjust the field. Pressing the ENTER button once more will confirm the setting. Exit the main menu at any time without making any adjustments by pressing the MODE button.

The display screen will shut OFF automatically after 30 seconds of inactivity. To turn the display back on, press and hold the MODE button for 3 seconds.

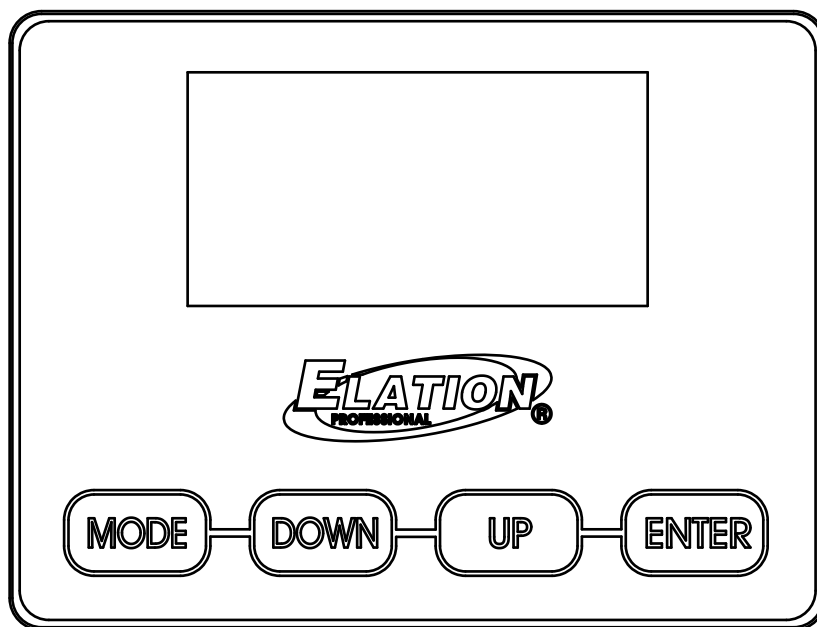

A copy of the latest software can be obtained by contacting Elation Support. AN ELATION C-LOADER II CAN ALSO BE USED TO UPDATE THE FIXTURE TO THE LATEST SOFTWARE. To order this device, please contact Elation Support for further details.

Detailed instructions can be found online at www.elationlighting.com.

ELATION SERVICE USA - Monday - Friday 8:00am to 4:30pm PST
323-582-3322 | Fax 323-832-9142 | support@elationlighting.com

ELATION SERVICE EUROPE - Monday - Friday 08:30 to 17:00 CET
+31 45 546 85 63 | Fax +31 45 546 85 96 | support@elationlighting.eu

SYSTEM MENU

MAIN MENU	OPTIONS / VALUES (Default Settings in BOLD)		
DMX SETTINGS	DMX Address	001 - 512	
	DMX Mode	Standard	
		Extended	
		RGB	
		RGB Extended	
		CMY	
	No DMX Status	Hold Last	
Fade to Black			
Standalone			
STANDALONE	Dimmer	Dimmer 0% - 100%	
	CCT	2400K - 8500K (Default = 6000K)	
	Green Shift	-100% ~ +100% (Default = 0)	
	Virtual Color	See Color Macros	
	Manual Control	Red 0-255	
		Green 0-255	
		Blue 0-255	
		Mint 0-255	
Amber 0-255			
...0-255			
PERSONALITY	Primary	On / Off	
	Secondary	On / Off	
	Select Signal	DMX or Wireless	
		Wireless IN and DMX OUT	
	Wireless Settings	Wireless Enable	ON/OFF
		Set Wireless Channel	0-14
	Dim Modes	Standard	
		Stage	
		TV	
		Architectural	
		Theatre	
		Stage 2	
	Dim Speed	0s - 10s (Default = 0.1s)	
	Dim Curves	Linear, Square, Square Inverse, S-Curve	
	LED Refresh Rate	900Hz - 1500Hz (1200 Hz), 2500Hz, 4000Hz, 5000Hz, 6000Hz, 10KHz, 15kHz, 20KHz, 25KHz	
	LED Power Limit	50%, 60%, 70%, 80%, 90%, 100%	
	Fan Mode	Auto , High, Low, Studio, Mute	
Display	Screen Delay	10s - 5min (Default = 1 min)	
	Screen Lock	Off , 10s - 5 min	
	Rotate Display	Yes / No / Auto	
Service (Passcode= 050)	Calibration	Red 000 - 255	
		Green 000 - 255	
		Blue 000 - 255	
		Mint 000 - 255	
	Amber 000 - 255		
Factory Restore	Yes / No		

SYSTEM MENU

MAIN MENU	OPTIONS / VALUES (Default Settings in BOLD)		
INFORMATION	Life Time		
	Last Run Time		
	Time Reset	Passcode= 038	
	Temperature	Current	
		Max Resettable	
		Reset	Passcode= 038
	DMX Values	Red	
		Green	
		...	
	Product IDs	RDM UID	
	Error Codes	Fixture Errors	
		Reset Error Log	Yes / No (Passcode= 050)
	Software Version		

DIMMER MODES & CURVES

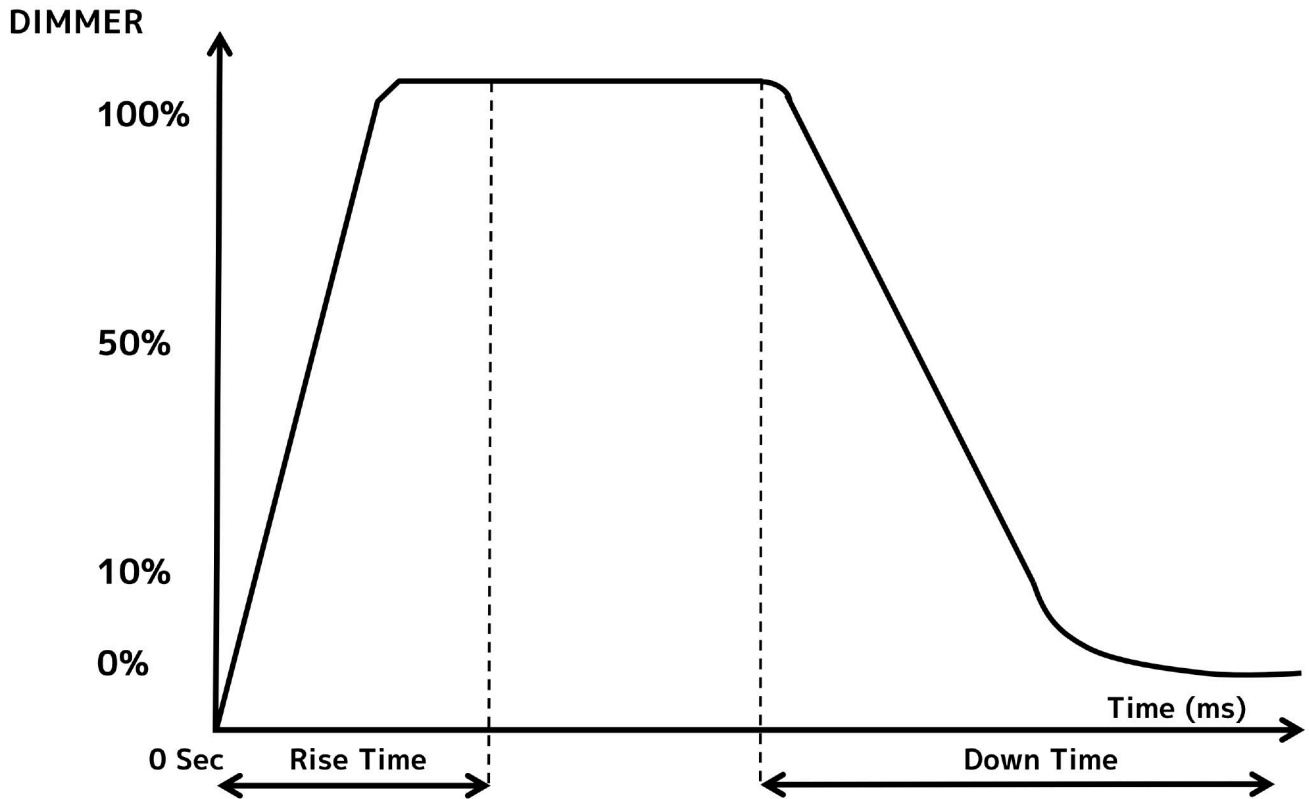

Dimming Curve Ramp Effect	0 sec Fade Time		1 sec Fade Time	
	Rise Time (ms)	Down Time (ms)	Rise Time (ms)	Down Time (ms)
Standard (default)	0	0	0	0
Stage	780	1100	1540	1660
TV	1180	1520	1860	1940
Architectural	1380	1730	2040	2120
Theatre	1580	1940	2230	2280
Stage 2	0	1100	0	1660

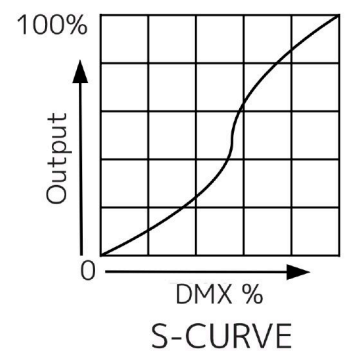
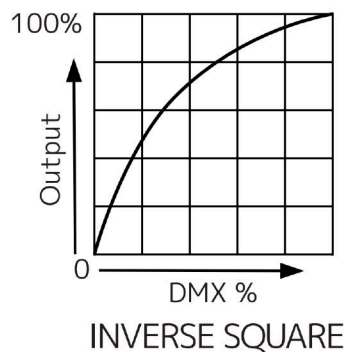
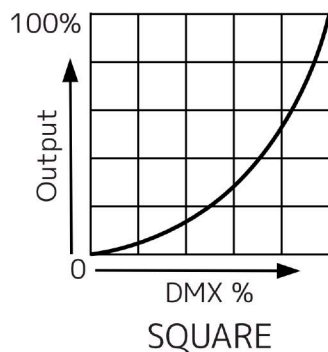
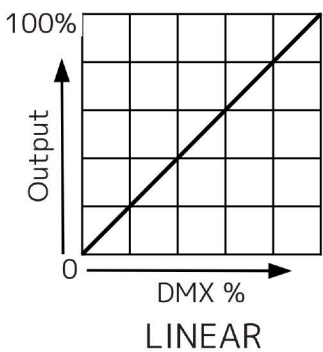

DMX TRAITS

Standard	Extended	RGB	RGB Extended	CMY	CMY Extended	DMX Values	Function	Snap	Default Value
1	1	1	1			0-255	Red		0
							0 → 100%		
	2		2			0-255	Red Fine		0
							Fine Adjustment		
2	3	2	3			0-255	Green		0
							0 → 100%		
	4		4			0-255	Green Fine		0
							Fine Adjustment		
3	5	3	5			0-255	Blue		0
							0 → 100%		
	3		6			0-255	Blue Fine		0
							Fine Adjustment		
4	7					0-255	Mint		0
							0 → 100%		
	8					0-255	Mint Fine		0
							Fine Adjustment		
5	9					0-255	Amber		0
							0 → 100%		
	10					0-255	Amber Fine		0
							Fine Adjustment		
				1	1	0-255	Cyan		0
							0 → 100%		
					2	0-255	Cyan Fine		0
							Fine Adjustment		
				2	3	0-255	Magenta		0
							0 → 100%		
					4	0-255	Magenta Fine		0
							Fine Adjustment		
				3	5	0-255	Yellow		0
							0 → 100%		
					6	0-255	Yellow Fine		0
							Fine Adjustment		
6	11	4	7	4	7		Variable CCT		0
						0-23	Open		
						24-85	2400K → 8500K (See Sheet)		
						86-255	8500K		

DMX TRAITS

Standard	Extended	RGB	RGB Extended	CMY	CMY Extended	DMX Values	Function	Snap	Default Value
7	12	5	8	5	8		Color		0
						0	Open		
						1-179	Virtual Swatch Book (See Sheet)		
							Scroll		
						180-201	Clockwise Fast → Slow		
						202-207	Stop		
						208-229	Counter-clockwise Slow → Fast		
						230-234	Open		
							Random Slots		
						235-239	Fast		
						240-244	Medium		
						245-249	Slow		
						250-255	Open		
	13		9		9		Green Shift		0
						0	Idle		
						1-127	Full Minus Green to Neutral		
						128	Neutral White		
						129-255	Neutral to Full Plus Green		
	14		10		10		CCT Crossfade		0
						0	CCT		
						1-254	Blend CCT → Color Mix		
						255	Color Mix		
8	15	6	11	6	11		Rotating Gobo Wheel		0
						0-9	Open		
						10-19	Rotating Gobo 1		
						20-29	Rotating Gobo 2		
						30-39	Rotating Gobo 3		
						40-49	Rotating Gobo 4		
						50-59	Rotating Gobo 5		
						60-69	Rotating Gobo 6		
						70-89	Gobo 1 Shake Slow → Fast		
						90-109	Gobo 2 Shake Slow → Fast		
						110-129	Gobo 3 Shake Slow → Fast		
						130-149	Gobo 4 Shake Slow → Fast		
						150-169	Gobo 5 Shake Slow → Fast		
						170-189	Gobo 6 Shake Slow → Fast		
							Scroll		
						190-221	Clockwise Fast → Slow		
						222-223	Stop		
224-255	Counter-clockwise Slow → Fast								

DMX TRAITS

Standard	Extended	RGB	RGB Extended	CMY	CMY Extended	DMX Values	Function	Snap	Default Value
9	16	7	12	7	12		Rotating Gobo Index/ Rotation		0
						0-127	Index Position		
							Rotate		
						128-189	Clockwise Fast → Slow		
						190-193	Stop		
	194-255	Counter-clockwise Slow → Fast							
10	17	8	13	8	13	0-255	Rotating Gobo Index/ Rotation Fine		0
							Fine Adjustment		
11	18	9	14	9	14		Fixed Gobo	X	0
						0-9	Open		
						10-19	Gobo 1		
						20-29	Gobo 2		
						30-39	Gobo 3		
						40-49	Gobo 4		
						50-59	Gobo 5		
						60-69	Gobo 6		
						70-77	Gobo 7		
						78-93	Gobo 1 shake slow to fast		
						94-109	Gobo 2 shake slow to fast		
						110-125	Gobo 3 shake slow to fast		
						126-141	Gobo 4 shake slow to fast		
						142-157	Gobo 5 shake slow to fast		
						158-173	Gobo 6 shake slow to fast		
174-189	Gobo 7 shake slow to fast								
		Scroll							
	190-221	Clockwise Fast → Slow							
	222-223	Stop							
	224-255	Counter-clockwise Slow → Fast							
12	19	10	15	10	15		Prism	X	0
						0-5	Open		
						6-31	Prism 1		
						32-127	Prism 2		
						128-255	Idle		
13	20	11	16	11	16		Prism Index/ Rotation		64
						0-127	Index Position		
							Rotate		
						128-189	Clockwise Fast → Slow		
						190-193	Stop		
	194-255	Counter-clockwise Slow → Fast							
14	21	12	17	12	17	0-255	Focus Infinity → Near		127
15	22	13	18	13	18	0-255	Focus Fine Fine Adjustment		127
16	23	14	19	14	19	0-255	Zoom Narrow → Wide		127
17	24	15	20	15	20	0-255	Zoom Fine Fine Adjustment		127

DMX TRAITS

Standard	Extended	RGB	RGB Extended	CMY	CMY Extended	DMX Values	Function	Snap	Default Value
18	25	16	21	16	21		Strobe		50
						0-31	Closed		
						32-63	Open		
						64-95	Strobe effect slow to fast		
						96-127	Open		
						128-159	Pulse Effect		
						160-191	Open		
						192-223	Random Slow → Fast		
						224-255	Open		
19	26	17	22	17	22	0-255	Dimmer 0 → 100%		0
20	27	18	23	18	23	0-255	Dimmer Fine Fine Adjustment	X	0
	28		24		24		Dim Modes	X	0
						0-20	Standard		
						21-40	Stage		
						41-60	TV		
						61-80	Architectural		
						81-100	Theatre		
						101-120	Stage 2		
							Dimmer Delay Time		
						121	0s		
						122	0.1s		
						123	0.2s		
						124	0.3s		
						125	0.4s		
						126	0.5s		
						127	0.6s		
						128	0.7s		
						129	0.8s		
						130	0.9s		
						131	1.0s		
						132	1.5s		
						133	2.0s		
						134	3.0s		
						135	4.0s		
						136	5.0s		
137	6.0s								
138	7.0s								
139	8.0s								
140	9.0s								
141	10s								
142-255	Idle								
21	29	19	25	19	25	0-255	Frost Open → Closed		0
22	30	20	26	20	26		Animation Wheel		0
						0-7	Open		
						8-255	Animation Min → Max		
23	31	21	27	21	27		Animation Index/ Rotation		64
						0-127	Index Position		
							Rotate		
						128-189	Clockwise Fast → Slow		
						190-193	Stop		
						194-255	Counter-clockwise Slow → Fast		

DMX TRAITS

Standard	Extended	RGB	RGB Extended	CMY	CMY Extended	DMX Values	Function	Snap	Default Value
24	32	22	28	22	28		Control	X	0
						0-19	Wheel Snap		
						20-39	Wheel Fade		
							Fan Mode		
						40-44	Studio		
						45-49	Mute		
						50-59	Low		
						60-69	High		
						70-79	Auto (default)		
							Reset		
						80-84	All		
						85-90	Idle		
						91-93	Gobo		
						94-96	Focus and Zoom		
						97-99	Other		
							Refresh Rate (Hz)		
						100	900		
						101	910		
						102	920		
						103	930		
						104	940		
						105	950		
						106	960		
						107	970		
						108	980		
						109	990		
						110	1000		
						111	1010		
						112	1020		
						113	1030		
114	1040								
115	1050								
116	1060								
117	1070								
118	1080								
119	1090								
120	1100								
121	1110								
122	1120								
123	1130								
124	1140								
125	1150								
126	1160								
127	1170								
128	1180								
129	1190								
	1200 (default)								

DMX TRAITS

Standard	Extended	RGB	RGB Extended	CMY	CMY Extended	DMX Values	Function	Snap	Default Value
24	32	22	28	22	28	131	1210	X	0
						132	1220		
						133	1230		
						134	1240		
						135	1250		
						136	1260		
						137	1270		
						138	1280		
						139	1290		
						140	1300		
						141	1310		
						142	1320		
						143	1330		
						144	1340		
						145	1350		
						146	1360		
						147	1370		
						148	1380		
						149	1390		
						150	1400		
						151	1410		
						152	1420		
						153	1430		
						154	1440		
						155	1450		
						156	1460		
						157	1470		
						158	1480		
						159	1490		
						160	1500		
						161	2500		
						162	4000		
163	5000								
164	6000								
165	10000								
166	15000								
167	20000								
168	25000								
169-200	Idle								
	Dimmer Curves								
201-210	Linear								
211-220	Square								
221-230	Inverse Square								
231-240	S-Curve (Default)								
241-255	Idle								

DMX TRAITS - FRAMING MODULE

Standard	Extended	RGB	RGB Extended	CMY	CMY Extended	DMX Values	Function	Snap	Default Value	
1	1	1	1			0-255	Red		0	
							0 → 100%			
	2		2			0-255	Red Fine		0	
							Fine Adjustment			
2	3	2	3			0-255	Green		0	
							0 → 100%			
	4		4			0-255	Green Fine		0	
							Fine Adjustment			
3	5	3	5			0-255	Blue		0	
							0 → 100%			
	3		6			0-255	Blue Fine		0	
							Fine Adjustment			
4	7					0-255	Mint		0	
							0 → 100%			
	8					0-255	Mint Fine		0	
							Fine Adjustment			
5	9					0-255	Amber		0	
							0 → 100%			
	10					0-255	Amber Fine		0	
							Fine Adjustment			
				1	1	0-255	Cyan		0	
							0 → 100%			
					2	0-255	Cyan Fine		0	
							Fine Adjustment			
				2	3	0-255	Magenta		0	
							0 → 100%			
					4	0-255	Magenta Fine		0	
							Fine Adjustment			
				3	5	0-255	Yellow		0	
							0 → 100%			
					6	0-255	Yellow Fine		0	
							Fine Adjustment			
6	11	4	7	4	7		Variable CCT		0	
							0-23			Open
							24-85			2400K → 8500K (See Sheet)
							86-255			8500K

DMX TRAITS - FRAMING MODULE

Standard	Extended	RGB	RGB Extended	CMY	CMY Extended	DMX Values	Function	Snap	Default Value
7	12	5	8	5	8		Color		0
						0	Open		
						1-179	Virtual Swatch Book (See Sheet)		
							Scroll		
						180-201	Clockwise Fast → Slow		
						202-207	Stop		
						208-229	Counter-clockwise Slow → Fast		
						230-234	Open		
							Random Slots		
						235-239	Fast		
						240-244	Medium		
						245-249	Slow		
						250-255	Open		
							13		
0	Idle								
1-127	Full Minus Green to Neutral								
128	Neutral White								
						129-255	Neutral to Full Plus Green		
	14		10		10		CCT Crossfade		0
						0	CCT		
						1-254	Blend CCT → Color Mix		
						255	Color Mix		
8	15	6	11	6	11		Rotating Gobo Wheel		0
						0-9	Open		
						10-19	Rotating Gobo 1		
						20-29	Rotating Gobo 2		
						30-39	Rotating Gobo 3		
						40-49	Rotating Gobo 4		
						50-59	Rotating Gobo 5		
						60-69	Rotating Gobo 6		
						70-89	Gobo 1 Shake Slow → Fast		
						90-109	Gobo 2 Shake Slow → Fast		
						110-129	Gobo 3 Shake Slow → Fast		
						130-149	Gobo 4 Shake Slow → Fast		
						150-169	Gobo 5 Shake Slow → Fast		
						170-189	Gobo 6 Shake Slow → Fast		
							Scroll		
						190-221	Clockwise Fast → Slow		
						222-223	Stop		
224-255	Counter-clockwise Slow → Fast								

DMX TRAITS - FRAMING MODULE

Standard	Extended	RGB	RGB Extended	CMY	CMY Extended	DMX Values	Function	Snap	Default Value
9	16	7	12	7	12		Rotating Gobo Index/ Rotation		0
						0-127	Index Position		
							Rotate		
						128-189	Clockwise Fast → Slow		
						190-193	Stop		
	194-255	Counter-clockwise Slow → Fast							
10	17	8	13	8	13	0-255	Rotating Gobo Index/ Rotation Fine		0
							Fine Adjustment		
11	18	9	14	9	14		Fixed Gobo	X	0
						0-9	Open		
						10-19	Gobo 1		
						20-29	Gobo 2		
						30-39	Gobo 3		
						40-49	Gobo 4		
						50-59	Gobo 5		
						60-69	Gobo 6		
						70-77	Gobo 7		
						78-93	Gobo 1 shake slow to fast		
						94-109	Gobo 2 shake slow to fast		
						110-125	Gobo 3 shake slow to fast		
						126-141	Gobo 4 shake slow to fast		
						142-157	Gobo 5 shake slow to fast		
						158-173	Gobo 6 shake slow to fast		
						174-189	Gobo 7 shake slow to fast		
							Scroll		
190-221	Clockwise Fast → Slow								
222-223	Stop								
	224-255	Counter-clockwise Slow → Fast							
12	19	10	15	10	15		Prism	X	0
						0-5	Open		
						6-31	Prism 1		
						32-127	Prism 2		
	128-255	Idle							
13	20	11	16	11	16		Prism Index/ Rotation		64
						0-127	Index Position		
							Rotate		
						128-189	Clockwise Fast → Slow		
						190-193	Stop		
	194-255	Counter-clockwise Slow → Fast							

DMX TRAITS - FRAMING MODULE

Standard	Extended	RGB	RGB Extended	CMY	CMY Extended	DMX Values	Function	Snap	Default Value
14	21	12	17	12	17	0-255	Focus Infinity → Near		127
15	22	13	18	13	18	0-255	Focus Fine Fine Adjustment		127
16	23	14	19	14	19	0-255	Zoom Narrow → Wide		127
17	24	15	20	15	20	0-255	Zoom Fine Fine Adjustment		127
18	25	16	21	16	21		Strobe	X	50
						0-31	Closed		
						32-63	Open		
						64-95	Strobe effect Slow → Fast		
						96-127	Open		
						128-159	Pulse Effect		
						160-191	Open		
						192-223	Random Slow → Fast		
224-255	Open								
19	26	17	22	17	22	0-255	Dimmer 0 → 100%		0
20	27	18	23	18	23	0-255	Dimmer Fine Fine Adjustment		0
	28		24		24		Dim Modes	X	0
						0-20	Standard		
						21-40	Stage		
						41-60	TV		
						61-80	Architectural		
						81-100	Theatre		
						101-120	Stage 2		
							Dimmer Delay Time		
						121	0s		
						122	0.1s		
						123	0.2s		
						124	0.3s		
						125	0.4s		
						126	0.5s		
						127	0.6s		
						128	0.7s		
						129	0.8s		
						130	0.9s		
						131	1.0s		
						132	1.5s		
						133	2.0s		
						134	3.0s		
						135	4.0s		
						136	5.0s		
137	6.0s								
138	7.0s								
139	8.0s								
140	9.0s								
141	10s								
142-255	Idle								

DMX TRAITS - FRAMING MODULE

Standard	Extended	RGB	RGB Extended	CMY	CMY Extended	DMX Values	Function	Snap	Default Value
21	29	19	25	19	25		Iris		0
						0-191	Open → Closed		
						192-223	Opening Pulse Fast → Slow		
						224-255	Closing Pulse Slow → Fast		
22	30	20	26	20	26	0-255	Frost Open → Closed		0
							Animation Wheel		
						0-7	Open		0
						8-255	Animation Min → Max		
							Animation Index/ Rotation		
						0-127	Index Position		64
							Rotate		
						128-189	Clockwise Fast → Slow		
						190-193	Stop		
25	33	23	29	23	29	0-255	Blade 1 A Open → Closed		0
							Blade 1 A Fine Fine Adjustment		
26	34	24	30	24	30	0-255	Blade 1 B Open → Closed		0
							Blade 1 B Fine Fine Adjustment		
27	35	25	31	25	31	0-255	Blade 2 A Open → Closed		0
							Blade 2 A Fine Fine Adjustment		
28	36	26	32	26	32	0-255	Blade 2 B Open → Closed		0
							Blade 2 B Fine Fine Adjustment		
29	37	27	33	27	33	0-255	Blade 3 A Open → Closed		0
							Blade 3 A Fine Fine Adjustment		
30	38	28	34	28	34	0-255	Blade 3 B Open → Closed		0
							Blade 3 B Fine Fine Adjustment		
31	39	29	35	29	35	0-255	Blade 4 A Open → Closed		0
							Blade 4 A Fine Fine Adjustment		
32	40	30	36	30	36	0-255	Blade 4 B Open → Closed		0
							Blade 4 B Fine Fine Adjustment		
33	41	31	37	31	37		Framing Rotation		127
						0-126	Min (-60°)		
						127-128	Parallel (0°)		
	42		38		38	0-255	Blade 3 A Fine Fine Adjustment		0
	43		39		39	0-255	Blade 3 B Open → Closed		0
	44		40		40	0-255	Blade 3 B Fine Fine Adjustment		0
	45		41		41	0-255	Blade 4 A Open → Closed		0
	46		42		42	0-255	Blade 4 A Fine Fine Adjustment		0
	47		43		43	0-255	Blade 4 B Open → Closed		0
	48		44		44	0-255	Blade 4 B Fine Fine Adjustment		0
	49		45		45	0-126	Min (-60°)		127
						127-128	Parallel (0°)		
						129-255	Max (+60°)		

DMX TRAITS - FRAMING MODULE

Standard	Extended	RGB	RGB Extended	CMY	CMY Extended	DMX Values	Function	Snap	Default Value
34	50	32	46	32	46		Control	X	0
						0-19	Wheel Snap		
						20-39	Wheel Fade		
							Fan Mode		
						40-44	Studio		
						45-49	Mute		
						50-59	Low		
						60-69	High		
						70-79	Auto (default)		
							Reset		
						80-84	All		
						85-90	Idle		
						91-93	Gobo		
						94-96	Focus and Zoom		
						97-99	Other		
							Refresh Rate (Hz)		
						100	900		
						101	910		
						102	920		
						103	930		
						104	940		
						105	950		
						106	960		
						107	970		
						108	980		
						109	990		
						110	1000		
						111	1010		
						112	1020		
						113	1030		
114	1040								
115	1050								
116	1060								
117	1070								
118	1080								
119	1090								
120	1100								
121	1110								
122	1120								
123	1130								
124	1140								
125	1150								
126	1160								
127	1170								
128	1180								
129	1190								
	130	1200 (default)							

DMX TRAITS - FRAMING MODULE

Standard	Extended	RGB	RGB Extended	CMY	CMY Extended	DMX Values	Function	Snap	Default Value
34	50	32	46	32	46	131	1210	X	0
						132	1220		
						133	1230		
						134	1240		
						135	1250		
						136	1260		
						137	1270		
						138	1280		
						139	1290		
						140	1300		
						141	1310		
						142	1320		
						143	1330		
						144	1340		
						145	1350		
						146	1360		
						147	1370		
						148	1380		
						149	1390		
						150	1400		
						151	1410		
						152	1420		
						153	1430		
						154	1440		
						155	1450		
						156	1460		
						157	1470		
						158	1480		
						159	1490		
						160	1500		
161	2500								
162	4000								
163	5000								
164	6000								
165	10000								
166	15000								
167	20000								
168	25000								
169-200	Idle								
	Dimmer Curves								
201-210	Linear								
211-220	Square								
221-230	Inverse Square								
231-240	S-Curve (Default)								
241-255	Idle								

COLOR TEMPERATURE CHART

DMX VALUE	COLOR TEMPERATURE (K)	DMX VALUE	COLOR TEMPERATURE (K)
24	2400	55	5500
25	2500	56	5600
26	2600	57	5700
27	2700	58	5800
28	2800	59	5900
29	2900	60	6000
30	3000	61	6100
31	3100	62	6200
32	3200	63	6300
33	3300	64	6400
34	3400	65	6500
35	3500	66	6600
36	3600	67	6700
37	3700	68	6800
38	3800	69	6900
39	3900	70	7000
40	4000	71	7100
41	4100	72	7200
42	4200	73	7300
43	4300	74	7400
44	4400	75	7500
45	4500	76	7600
46	4600	77	7700
47	4700	78	7800
48	4800	79	7900
49	4900	80	8000
50	5000	81	8100
51	5100	82	8200
52	5200	83	8300
53	5300	84	8400
54	5400	85	8500

VIRTUAL SWATCH BOOK

VALUE	FILTER #	COLOR	VALUE	FILTER #	COLOR
1	7	pale yellow	31	126	mauve
2	103	straw	32	49	medium purple
3	151	gold tint	33	58	lavender
4	100	spring yellow	34	199	palace blue
5	10	medium yellow	35	119	dark blue
6	101	yellow	36	132	medium blue
7	104	deep amber	37	120	deep blue
8	15	deep straw	38	165	daylight blue
9	179	loving amber	39	161	slate blue
10	21	gold amber	40	118	light blue
11	105	orange	41	68	sky blue
12	158	deep orange	42	143	pale navy blue
13	22	dark amber	43	131	marine blue
14	778	millenium gold	44	115	peacock blue
15	135	deep golden amber	45	172	lagoon blue
16	24	scarlet	46	116	medium blue green
17	106	primary red	47	90	dark yellow green
18	26	bright red	48	139	primary green
19	27	medium red	49	122	fern green
20	19	fire	50	89	moss green
21	157	pink	51	124	dark green
22	36	medium pink	52	88	lime green
23	111	dark pink	53	138	pale green
24	128	bright pink	54	203	Quarter CT Blue
25	148	bright rose	55	202	Half CT Blue
26	332	special rose pink	56	201	FULL CT Blue
27	793	vanity fair	57	200	double CT Blue
28	113	magenta	58	206	Quarter CT Orange
29	46	dark magenta	59	205	Half CT Orange
30	48	rose purple	60	204	FULL CT Orange

ERROR CODES

Error Codes subject to change without notice	
ERROR CODES	DESCRIPTION
RotGobo	Rotating Gobo Error
RotGoboIndex	Rotating Gobo Index Error
FixedGobo	Fixed Gobo Error
Animation	Animation Error
Zoom	Zoom Error
Focus	Focus Error
Prism1	Prism1 Error
Prism1Rot	Prism1 Rotation Error
Prism2	Prism2 Error
Prism2Rot	Prism2 Rotation Error
LED Fan1	LED Fan1 Error
LED Fan2	LED Fan2Error
LED Fan3	LED Fan3 Error
LED Fan4	LED Fan4 Error
HeadFan1	HeadFan1 Error
HeadFan2	HeadFan2 Error
Gobo Fan1	Gobo Fan1 Error
Gobo Fan2	Gobo Fan2 Error
Base Fan	Base Fan Error
Head Temp	Head Temperature Error
LED Temp	LED Temperature Error

MAINTENANCE GUIDELINES



DISCONNECT POWER BEFORE PERFORMING ANY MAINTENANCE!

CLEANING

Frequent cleaning is recommended to ensure proper function, optimized light output, and an extended life. The frequency of cleaning depends on the environment in which the fixture operates: damp, smoky or particularly dirty environments can cause greater accumulation of dirt on the fixture's optics. Clean periodically with a soft cloth to avoid dirt/debris accumulation.

NEVER use alcohol, solvents, or ammonia-based cleaners.

MAINTENANCE

Regular inspections are recommended to insure proper function and extended life. There are no user serviceable parts inside this fixture. Please refer all other service issues to an authorized Elation service technician. Should you need any spare parts, please order genuine parts from an authorized Elation dealer.

Please refer to the following points during routine inspections:

- A detailed electrical check by an approved electrical engineer every three months, to make sure the circuit contacts are in good condition and prevent overheating.
- Be sure all screws and fasteners are securely tightened at all times. Loose screws may fall out during normal operation, resulting in damage or injury as larger parts could fall.
- Check for any deformations on the housing, color lenses, rigging hardware and rigging points (ceiling, suspension, trussing). Deformations in the housing could allow for dust to enter into the fixture. Damaged rigging points or unsecured rigging could cause the fixture to fall and seriously injure a person(s).
- Electric power supply cables must not show any damage, material fatigue or sediments.

SPECIFICATIONS

SOURCE

305W 6,500K RGBMA LED Engine

30,000 Hour Average LED Life*

*Test lab conditions. May vary depending on several factors including but not limited to: Environmental Conditions, Power/Voltage, Usage Patterns (On-Off Cycling), Control, and Dimming.

PHOTOMETRIC DATA

10,600 Total Lumen Output

CRI 92

Zoom Range 7° - 50°

EFFECTS

Motorized Zoom

Variable Frost Filter

4 Facet Round, 4 Facet Linear Prism

Variable 16-bit Dimming Curve Modes

High Speed Electronic Shutter and Strobe

Optional Framing/Iris Module

COLOR

RGBMA Color Array

CMY and RGB Emulation Modes

Virtual Color Temperature 2400-8500K

Green/Magenta Shift

Virtual Gel Swatch Book

GOBOS

1x 6 Rotating / Indexing Glass Gobos

1x 7 Fixed Glass Gobo

Animation Wheel

CONTROL / CONNECTIONS

6 DMX Channel Modes (24/32) RGB or CMY (22/28)

6 DMX Channel Modes (Framing) (34/50) RGB or CMY (32/46)

16-bit Dimming Control

DMX Adjustable LED Frequency

DMX, RDM Protocol Support

4 Button Touch Control Panel

IP65 5pin DMX In/Out

IP65 Locking Power Cable In/Out

SIZE / WEIGHT

Length: 23.6" (599.2mm)

Length (Yoke 0°): 26.1" (662.9mm)

Width: 17.5" (445.5mm)

Height (Fixture Body): 9.5" (242.0mm)

Height (Yoke 90°): 17.4" (442.5mm)

Weight: 50.9 lbs (23.1kg)

Weight (with Framing Module) 55.1lbs (25kg)

ELECTRICAL / THERMAL

AC 100-240V - 50/60Hz

448W Max Power Consumption

14°F to 113°F (-10°C to 45°C)

BTU/hr (+/- 10%) 1406.7

INCLUDED ITEMS

IP65 Locking Power Cable

OPTIONAL ITEMS

Motorized Framing and Iris Module

APPROVALS / RATINGS

CE | cETLus | IP65 | FCC | UKCA

Specifications and documentation subject to change without notice.

DIMENSIONAL DRAWINGS

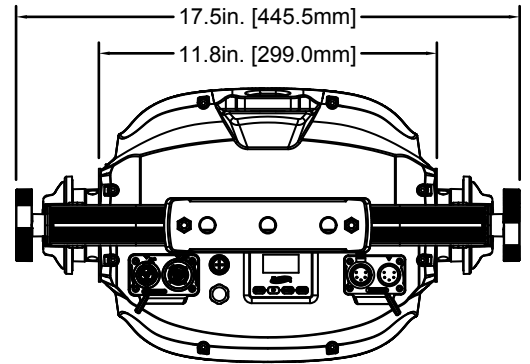
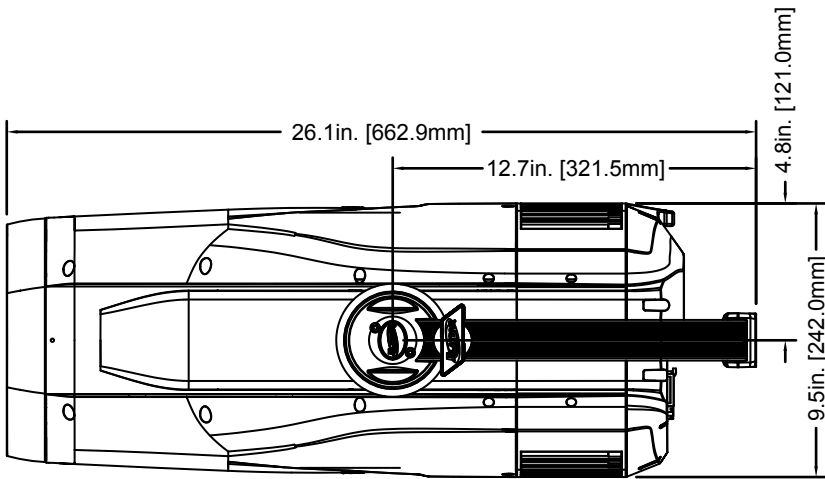
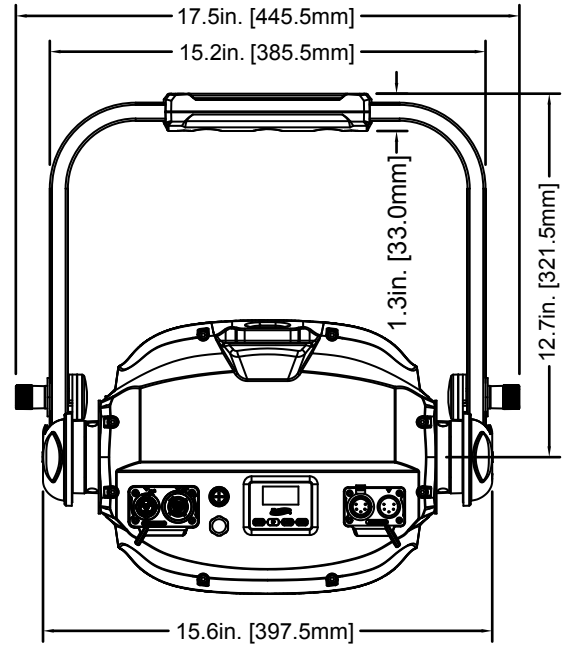
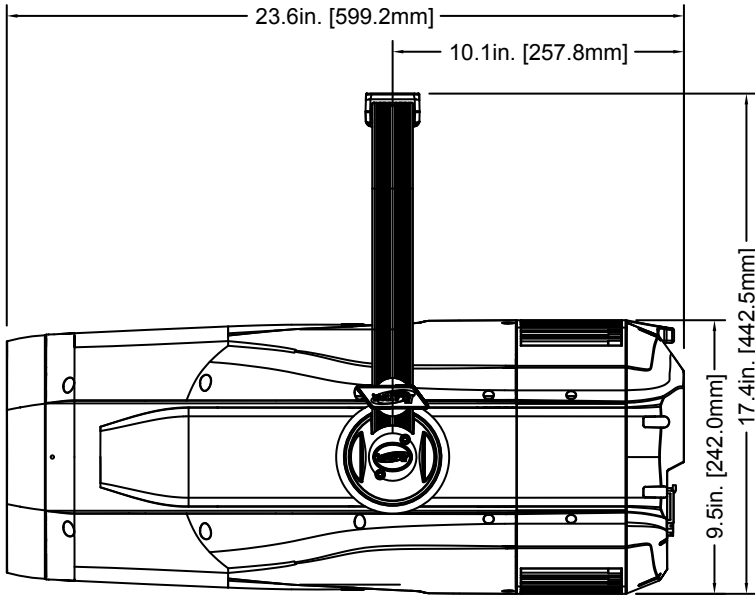

ORDERING INFORMATION

SKU US/EU	ITEM DESCRIPTION
KLS445/1236100189	KL SPOT IP
KLS556	KL SPOT IP FRAMING MODULE



FCC STATEMENT

This device complies with Part 15 of the FCC Rules. Operation is subject to the following two conditions: (1) this device may not cause harmful interference, and (2) this device must accept any interference received, including interference that may cause undesired operation.

FCC RADIO FREQUENCY INTERFERENCE WARNINGS & INSTRUCTIONS

This product has been tested and found to comply with the limits as per Part 15 of the FCC Rules. These limits are designed to provide reasonable protection against harmful interference in a residential installation. This device uses and can radiate radio frequency energy and, if not installed and used in accordance with the included instructions, may cause harmful interference to radio communications. However, there is no guarantee that interference will not occur in a particular installation. If this device does cause harmful interference to radio or television reception, which can be determined by turning the device off and on, the user is encouraged to try to correct the interference by one or more of the following methods:

- Reorient or relocate the device.
- Increase the separation between the device and the receiver.
- Connect the device to an electrical outlet on a circuit different from which the radio receiver is connected.
- Consult the dealer or an experienced radio/TV technician for help.

Energy Saving Matters (EuP 2009/125/EC)

Saving electric energy is a key to help protecting the environment. Please turn off all electrical products when they are not in use. To avoid power consumption in idle mode, disconnect all electrical equipment from power when not in use. Thank you!

