

SULLY 650SX

LED PROFILE SPOT

Manual

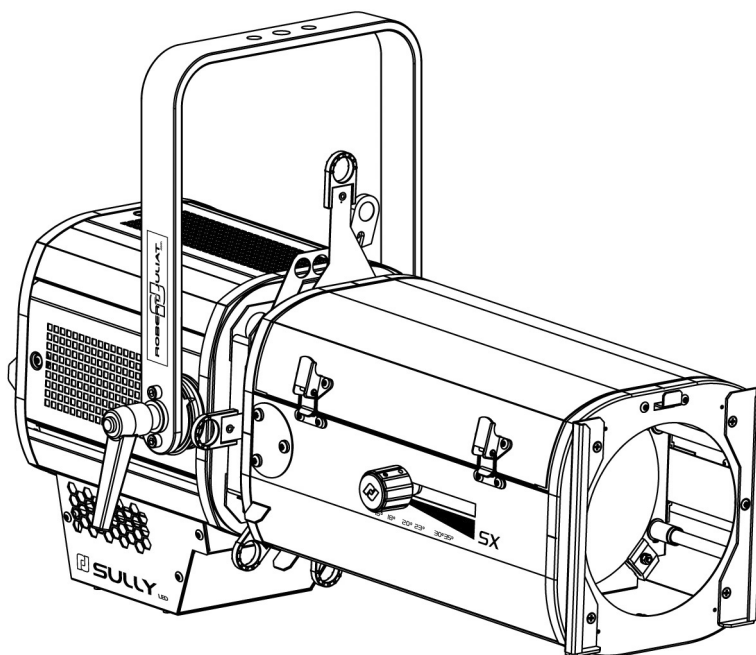

115 W LED

REF	Standard	North American
28 - 54°	653SX	653CSX
16 - 35°	654SX	654CSX
11 - 26°	651SX	651CSX

V1

- FIRMWARE: V3.0
- RJ-LED2 FIRMWARE PLATFORM (Node Mode) full manual is
available for download at robertjuliat.com/LED/PDF_PAGE

VALIDATION : 24/03/22

DN41201900-A (EN)



ROBERT JULIAT

Table of Contents

1	User's instructions	1
2	Presentation	2
2.1	Functions	2
2.2	Identification labels	2
2.2.1	Label on LED compartment	2
2.2.2	Label on lighting unit	3
2.3	Accessories included.....	3
2.4	Accessories	4
3	Set-up	5
3.1	Mechanics	5
3.1.1	Operating positions	5
3.1.2	Minimum distance between a flammable material and the lighting unit	5
3.1.3	Instructions for use	5
3.1.4	Hanging	5
3.1.5	Safety cable	6
3.2	Electrical information	6
3.2.1	LED source	6
3.2.2	Power supply.....	6
3.3	DATA	7
3.3.1	DMX 512-A / RDM.....	7
3.3.2	Art-Net / sACN	8
3.3.3	Ethernet / DMX node.....	8
3.4	Accessories	9
3.4.1	Front filter holder	9
3.4.2	Double-condenser set	9
3.4.3	Internal filter holder	10
3.4.4	Gobo holder / Iris	10
3.4.5	Shutters	11
4	Operations	12
4.1	Light intensity	12
4.1.1	Range.....	12
4.1.2	Control	12
4.1.3	Parameters.....	12
4.1.3.1	Dimming resolution - DMX only	12
4.1.3.2	Dimming curve	12
4.1.3.3	Set maximum position	13
4.1.3.4	Dimming mode	13
4.2	Strobe.....	14
4.2.1	Range.....	14
4.2.2	Control	14
4.3	Response time.....	14
4.3.1	Range.....	14
4.3.2	Control	14
4.4	Beam size adjustment.....	15
4.4.1	Range.....	15
4.4.2	Control	15
4.5	Orientation.....	15
4.5.1	Range.....	15
4.5.2	Control	16
4.6	Colour	16
4.7	Beam shaping	17
4.7.1	Range.....	17
4.7.2	Control.....	17
4.8	Beam rotation.....	18
4.8.1	Range.....	18
4.8.2	Control.....	18
4.9	Gobos.....	19
5	Controls and parameters	20
5.1	Web interface.....	20
5.1.1	Control	20
5.1.2	Default IP address.....	20
5.1.3	Network IP of the computer	20
5.1.4	Connect to web interface	20
5.1.5	CCT selection	21
5.2	LEDs Feedback.....	22
5.2.1	Trouble shooting	22
5.2.2.1	Intensity.....	22
5.2.2.2	Auto-OFF.....	22
5.3	DMX512 - A remote control.....	23
5.3.1	Protocol.....	23
5.3.2	Configuration.....	23
5.3.3	Parameters.....	23
5.3.3.1	DMX Hold.....	24
5.3.4	DMX chart	25
5.3.5	DMX ranges.....	25
5.3.5.1	Strobe duration	25
5.3.5.2	Strobe speed	25
5.3.5.3	Response time	25
5.3.5.4	Control mode	25
5.4	RDM remote control.....	26
5.4.1	Protocol.....	26
5.4.2	Functions	26
5.5	Art-Net remote control	28
5.5.1	Protocol.....	28
5.5.2	Configuration	28
5.5.3	Local set-up	29
5.6	sACN remote control	30
5.6.1	Protocol.....	30
5.6.2	Configuration	30
5.6.3	Local set-up.....	31
5.7	Local display and controls (option).....	32
5.7.1	Display.....	32
5.7.2	Menus.....	33
5.7.3	Parameters.....	34
6	Service	34
6.1	Preventive maintenance.....	35
6.1.1	Frequency	35
6.1.2	General cleaning.....	35
6.1.3	General visual check	35
6.1.4	LED source.....	35
6.1.5	Optics.....	35
6.1.6	LED house cleaning.....	35
6.2	Analysis.....	36
6.3	Electronic thermal management system.....	37
6.4	Firmware update.....	37
6.5	Factory defaults.....	38
6.5.1	Modes.....	38
6.5.2	Control	38

GENERAL INSTRUCTIONS

1. Not for residential use.
2. These fixtures must only be serviced by a qualified technician.
3. In addition to the instructions indicated on this page, relevant health and safety requirements of the appropriate EU Directives must be adhered to at all times.
4. This fixture is in compliance with section 17 - Lighting appliance for theatre stages, television, cinema and photograph studios. Standards NF EN 60598-1, NF EN 60598-2-17, Low Voltage Directive 2014/35/UE & EMC Directive 2014/30/UE.
5. This fixture is rated as IP20, and is for indoor use only.

FIXTURE

6. Ensure fixture is correctly mounted on an appropriate support.
7. Protection screens and lenses must be replaced in the event of any damage, such as cracks or deep scratches, since these might reduce performance.
8. When hung or flown the fixture must be secured by an additional hanging accessory (such as a safety cable or bond) of suitable length.
9. Safety bonds or cables must be securely attached to the back of the fixture and be as short as possible, or rolled up as necessary, to minimise travel distance should the fixture be dislodged.
10. Movable accessories (scroller, etc.) must also be secured with a suitable safety cable or bond at the front of the fixture.
11. The combined weight of both the fixture and the accessories must be considered when choosing the load-bearing capability of safety cable or bond.
12. Do not open lighting fixture when the source is on.
13. WARNING: LED source become hot during use. Allow fixture to cool before servicing.
14. Do not tamper with design of fixture nor any of its safety features.
15. Tighten electrical mains cable connections regularly and replace with one of identical specification if damaged.
16. Use only with correct power supply.

VENTILATION

17. Keep well away from flammable material.
18. Not for outdoor use. Do not cover. Do not permit fixture to get wet.
19. To avoid overheating, do not obstruct air vents.
20. Ensure any cooling fans are in correct working order. If fans are not working, turn fixture off immediately and service as necessary.

CLEANING

21. Do not touch the LED source with your fingers.
22. To clean the optical parts, use a soft cloth in combination with distilled water or isopropyl alcohol recommended for coated optics. Do not use any cleaning product that contains solvents or abrasives, as these can cause surface damage. Dry with a soft lint-free cloth.
23. Regularly remove dust with a soft lint-free cloth.
24. If the fixture has filters, they must be cleaned frequently.

POWER SUPPLY

25. Disconnect from the mains before servicing.
26. Mains connection only. Do not connect to "electronic output" such as dimmer.
27. Ensure power supply circuit breakers, always remain accessible.

PLEASE NOTE

This product has been built to conform to European standards relating to professional lighting equipment. Any modification made to our products will void the manufacturers' warranty.

Risk group 2



CAUTION: Possibly hazardous optical radiation emitted from this product. Do not stare at operating lamp. Maybe harmful to the eye.

Group risk 2. Luminaires should be positioned so that prolonged staring into luminaire at a distance closer than 10,6m (651SX), 7,1m (653SX) & 11m (654SX) is not expected.

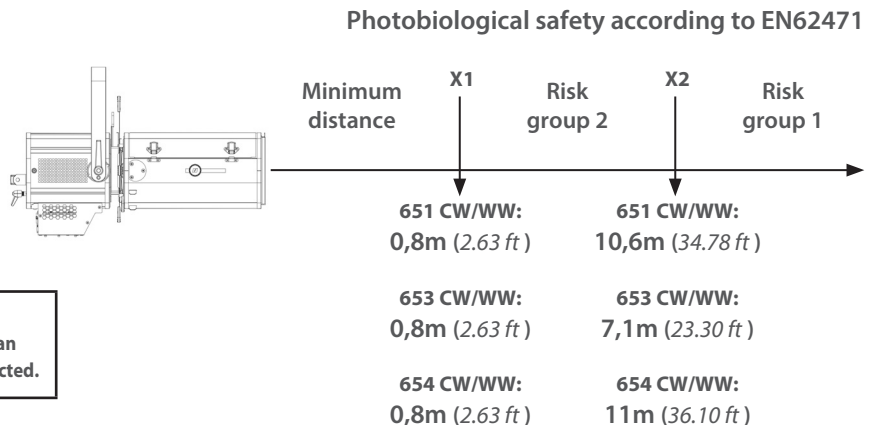

2 Presentation

2.1 Functions

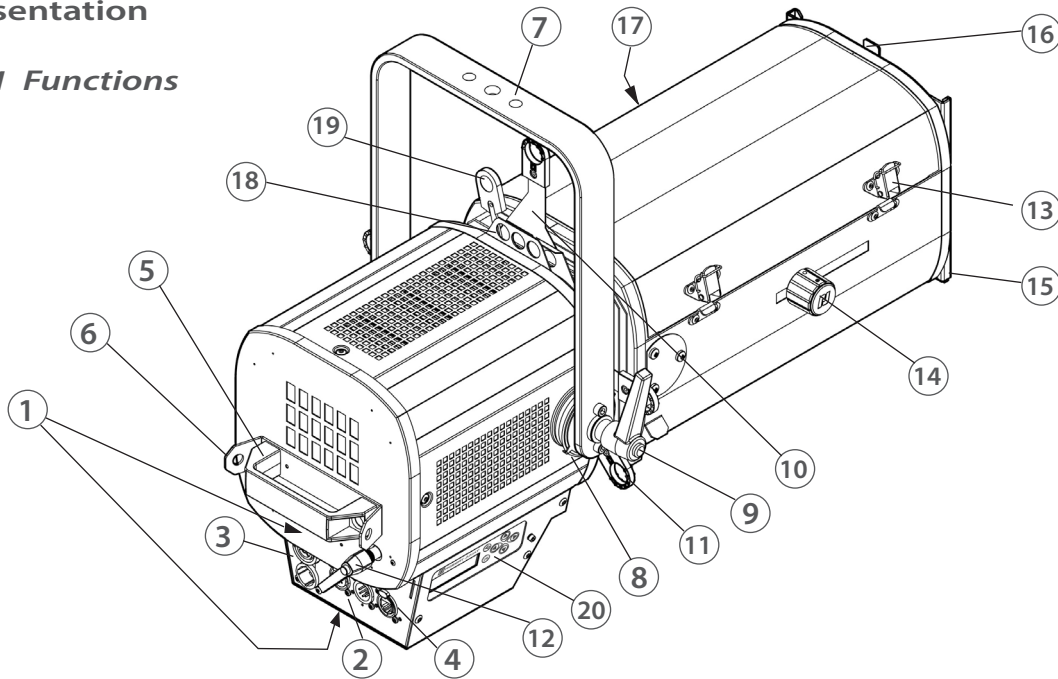

Description	
1. Identification plates	11. Shutter locking system
2. Data connector (IN and OUT)	12. Lens tube rotation locking button
3. Power connector (IN and OUT)	13. Lens tube access
4. RJ45 network connector	14. Focus adjustment
5. Handle	15. Front slot for accessories and gel frame holder
6. Safety cable attachment point	16. Front slot locking system
7. Hanging yoke	17. Zoom adjustment
8. Tilt index	18. Gobo holder
9. Tilt locking handle	19. Iris
10. Shutters	20. Local display and controls (option)

2.2 Identification labels

2.2.1 Label on LED compartment

Description	
<p>19 17 18 15 16 20</p> <p>LED FIXTURE Risk Group </p> <p>Lire le manuel avant utilisation - Utilisation et maintenance par professionnel uniquement / Read manual before use - Service only by qualified personnel.</p> <p>MOD. 1 VERS. 2 11 9</p> <p>U 3 I 4 10</p> <p>P 5 IP 6 13 14</p> <p>t^a 7 t^c 8 </p> <p>ROBERT JULIAT.com Made in the EU - France - 12 </p>	<ol style="list-style-type: none"> MOD. : Model VERS. : Version U : Nominal voltage input (V) I : Nominal intensity (A) P : Maximum power input (W) IP : International Protection Rating t^a : Maximum ambient temperature (°C) t^c : Maximum external temperature of the unit (°C) Net weight (kg) Minimum distance between a flammable material and the lighting unit (m) Colour temperature version Serial number Replace broken glass Class 1 product label Read manual first label European conformity label WEEE directive label CEI-TR-62778 - Do not stare at light source EN62471 - Risk group UKCA (UK Conformity Assessed) label
<p>Units :</p> <ul style="list-style-type: none"> - Weight = kilogram (kg). - Intensity = Ampere (A). - Voltage = Volt (V). - Frequency = Hertz (Hz). - Temperature = degree Celsius (°C). 	

Description

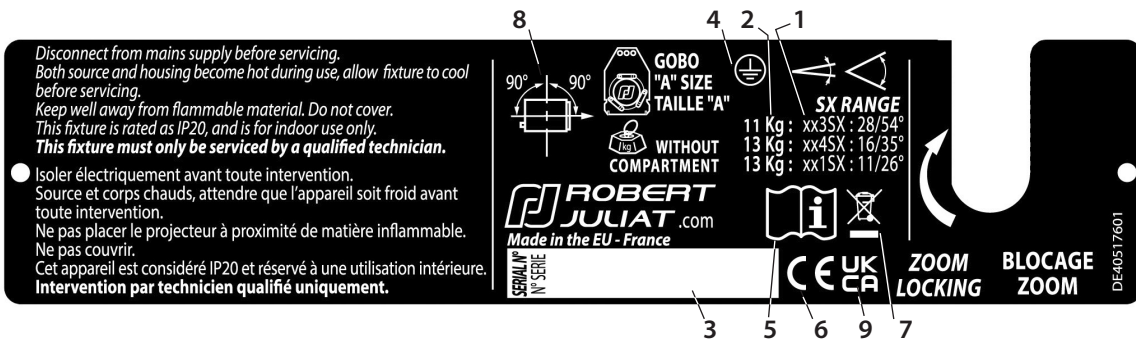

1. Model beam angles
2. Net weight (kg) without LED compartment
3. Serial number
4. Class 1 product label
5. Read manual first label
6. European conformity label
7. WEEE directive label
8. Operating positions
9. UKCA (UK Conformity Assessed) label

Units :
 - Weight = kilogram (kg).
 - Intensity = Ampere (A).
 - Voltage = Volt (V).
 - Frequency = Hertz (Hz).
 - Temperature = degree Celsius (°C).

2.3 Accessories included

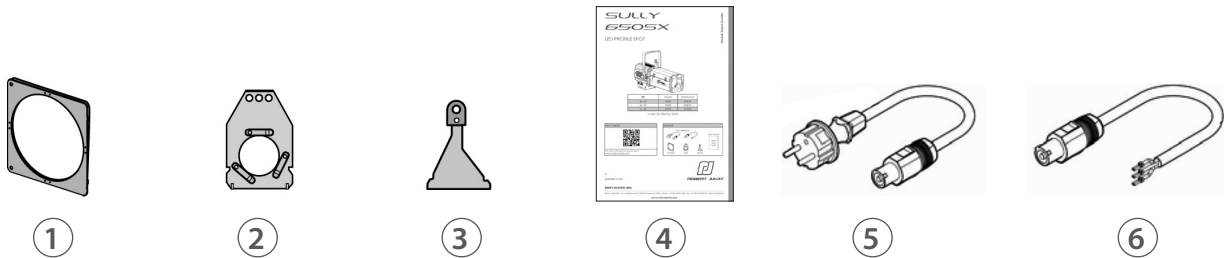

	Reference	Description
1	PF500M2	180 x 180 mm (7.1 x 7.1 in) metal filter holder
2	SGUX	Universal A-size gobo holder (metal, glass, frosted glass)
3	D8	Shutters (x4)
4	DN41202300	Quick Start manual
1	CAL03	3 meter power cable (3G1,5 HO7RNF) with Neutrik PowerCon® True1 TOP and CEE 7/7 (2P+T NF/SCHUKO) connectors (standard version)
2	CAL04	1,50m power cable UL/CSA with Neutrik PowerCon® True1 TOP connector (North American version)

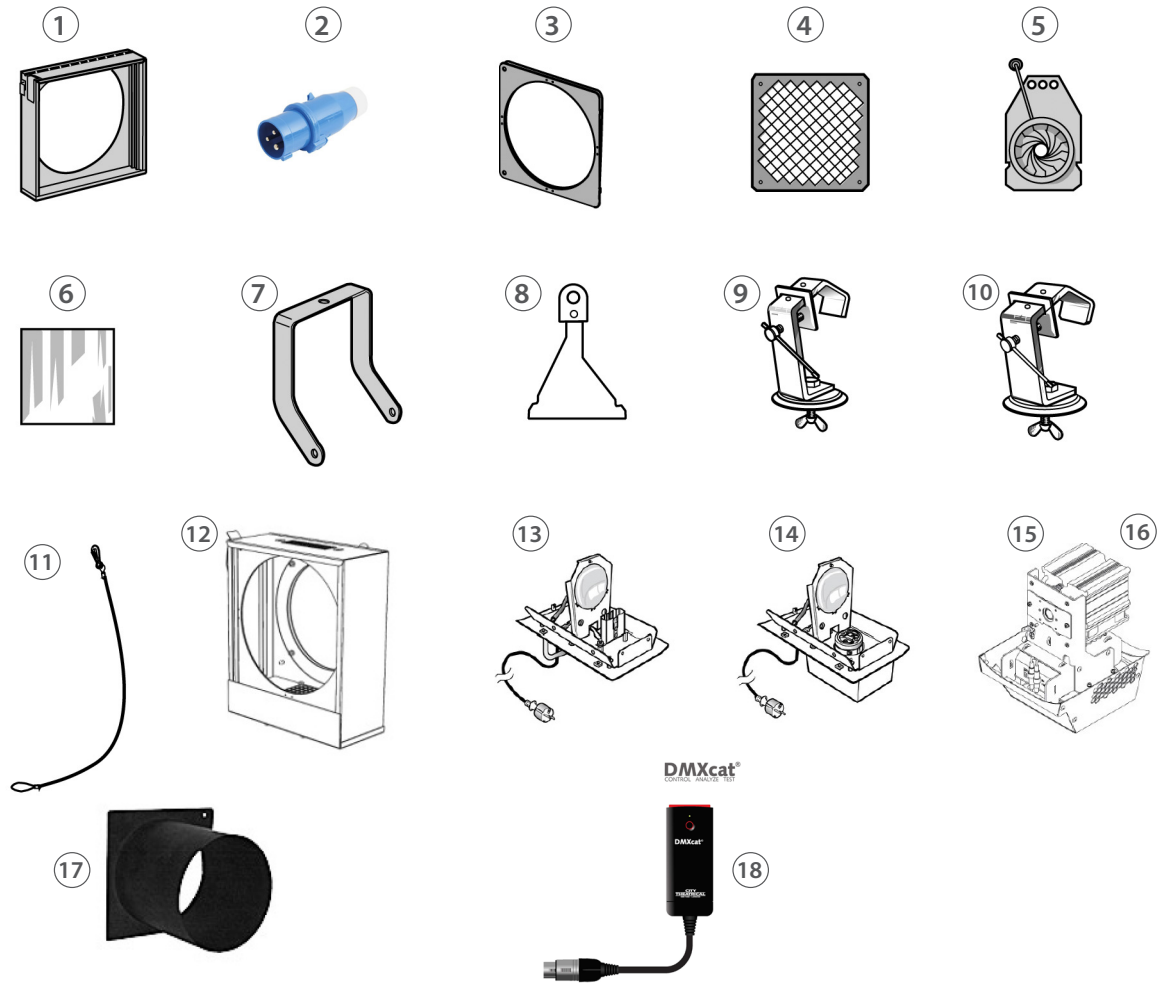

	Reference	Description
1	CAV 600A	Double slot front cassette for 180 x 180 mm accessories
	CAV 600AE	Double slot front cassette for 185 x 185 mm accessories
2	PCP1716A	16A blue 2P+E 6h IEC60309 power connector
3	PF600M2	185 x 185 mm (7.28 x 7.28 in) metal filter holder
4	G500	180 x 180 mm safety grid
5	IWSX755	Drop-in iris (monoplane) with holder
6	VD 120	120 x 120 mm inner frosted glass
7	FCD600	Angled yoke
8	D8	Shutter
9	876	40 x 10 mm hook clamp with 28 mm screw for Ø35 to Ø50mm
10	880	40 x 10 mm hook clamp with 28 mm screw for Ø50 to Ø63mm
11	CS2	Safety cable (length = 600 mm)
12	RPF613	180 x 180 mm front extension cassette for 215 x 215 mm accessories without fan (recommended for dark colours on 613SX/663SX)
	RPF613E	180 x 180 mm front extension cassette for 245 x 245 mm accessories without fan (recommended for dark colours on 613SX/663SX)
13	T/600SX	Lamp compartment for 1000/1200W tungsten GX9,5 lamps - 3 meter power cable with CEE 7/7 (2P+T NF/SCHUKO) connector
14	T/600VSX	Lamp compartment for 1000/1200W tungsten G22 lamps with fan - 3 meter power cable with CEE 7/7 (2P+T NF/SCHUKO) connector
15	T/650SXCW	SULLY 115 W LED compartment - Cool White - 3 meter power cable with CEE 7/7 (2P+T NF/SCHUKO) connector
16	T/650SXWW	SULLY 115 W LED compartment - Warm White - 3 meter power cable with CEE 7/7 (2P+T NF/SCHUKO) connector
17	TH600	180 x 180 mm "Top hat" (without safety cable)
18	DMXcat	Bluetooth DMX/RDM Multifunction test tool - City Theatrical DMXcat®

3 Set-up

3.1 Mechanics

3.1.1 Operating positions

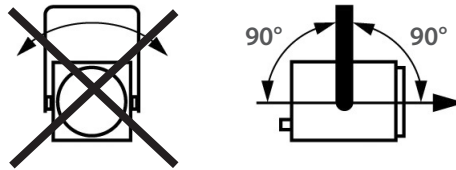

3.1.2 Minimum distance between a flammable material and the lighting unit

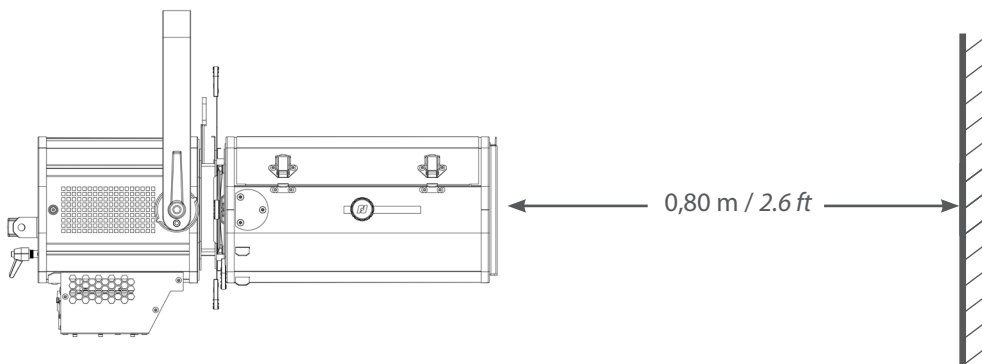

3.1.3 Instructions for use

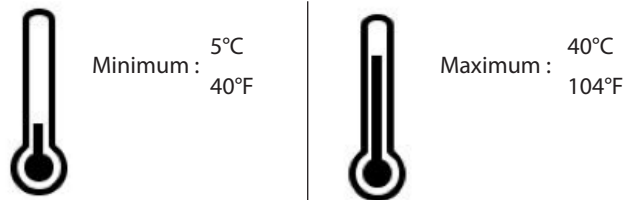

IP20 - Indoor use only

3.1.4 Hanging

- Ensure fixture is correctly mounted on an appropriate support

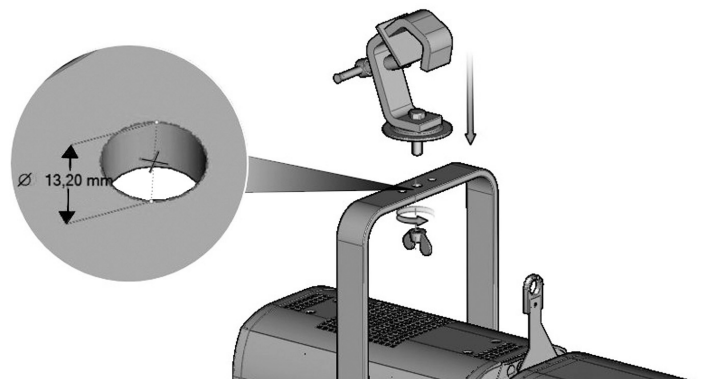

Net weight:
 653SX = 12.2 kg (26.8 lbs)
 654SX = 13.6 kg (29.9 lbs)
 651SX = 13.9 kg (30.6 lbs)

3.1.5 Safety cable

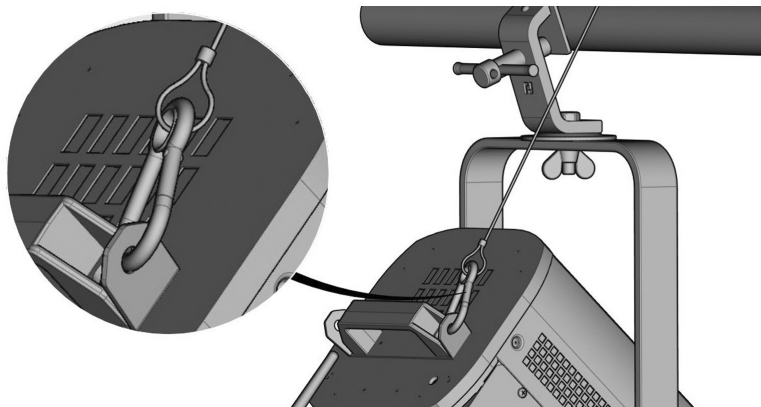

- When hung or flown the fixture must be secured by an additional hanging accessory (such as a safety bond or cable) of suitable length.
- The combined weight of both the fixture and the accessories must be considered when choosing the load-bearing capability of safety cable or bond.
- Safety cables or bonds must be securely attached to the back of the fixture and be as short as possible, or rolled up as necessary, to minimise travel distance should the fixture be dislodged.

3.2 Electrical information

3.2.1 LED source



Never touch or scratch the LED surface.
See 6.1.4 LED cleaning procedure if cleaning is necessary.

3.2.2 Power supply

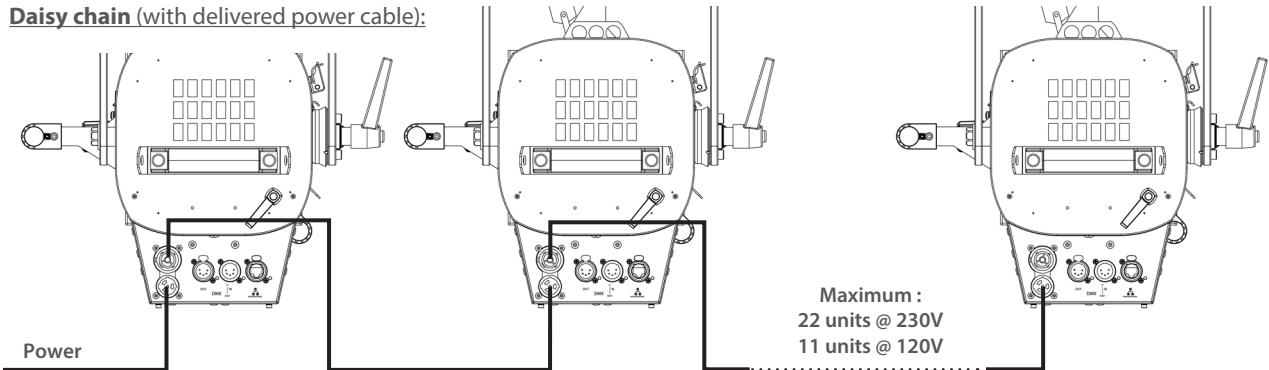
Power supply			
Voltage	Frequency	Input power	Connectors
100 → 264 V	50-60 Hz	0,7 A / 130 W @ 230V 1,15 A / 135 W @ 120V 1,40 A / 135 W @ 100V Max: 1,5A Standby mode: 10W	Neutrik powerCON TRUE1 TOP Input : ref. NAC3FPX-TOP
 <ul style="list-style-type: none"> • Class 1 product. This luminaire must be earthed. • Must be connected directly to AC power. Do not connect to dimmer power. • Automatic mains voltage detection. 			
<p>Daisy chain (with delivered power cable):</p>  <p>Maximum : 22 units @ 230V 11 units @ 120V</p>			

Power cable

Power cable		Connector	Mains plug	Cable type	Cable length	Wiring
1	Standard version	Neutrik® powerCON TRUE1 TOP NAC3FX-W-TOP	CEE7/7	3G1.5 H07RNF	3 m 9.8 ft	Live: Brown Neutral: Blue Ground: Yellow/Green
2	North American version		-	14AWG SJ TYPE (UL/CSA)	1.5 m 4.9 ft	Live: Black Neutral: White Ground: Green

3.3 DATA

3.3.1 DMX 512-A / RDM

Protocol	Input connector	Output connector
USITT DMX 512-A RDM	XLR 5-pin	XLR 5-pin

DATA connectors			
PIN #	DMX	Description	
1	Shielding	Foil & Braided Shield	
2	DMX (-)	1 st conductor of 1 st twisted pair	
3	DMX (+)	2 nd conductor of 1 st twisted pair	
4	Not used	1 st conductor of 2 nd twisted pair	
5	Not used	2 nd conductor of 2 nd twisted pair	

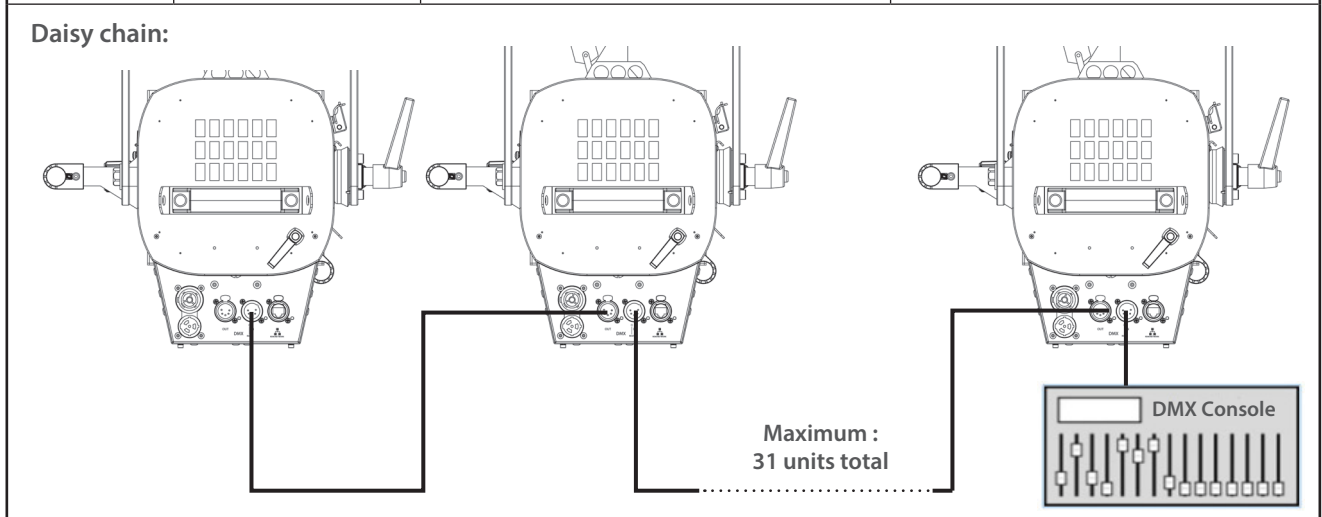

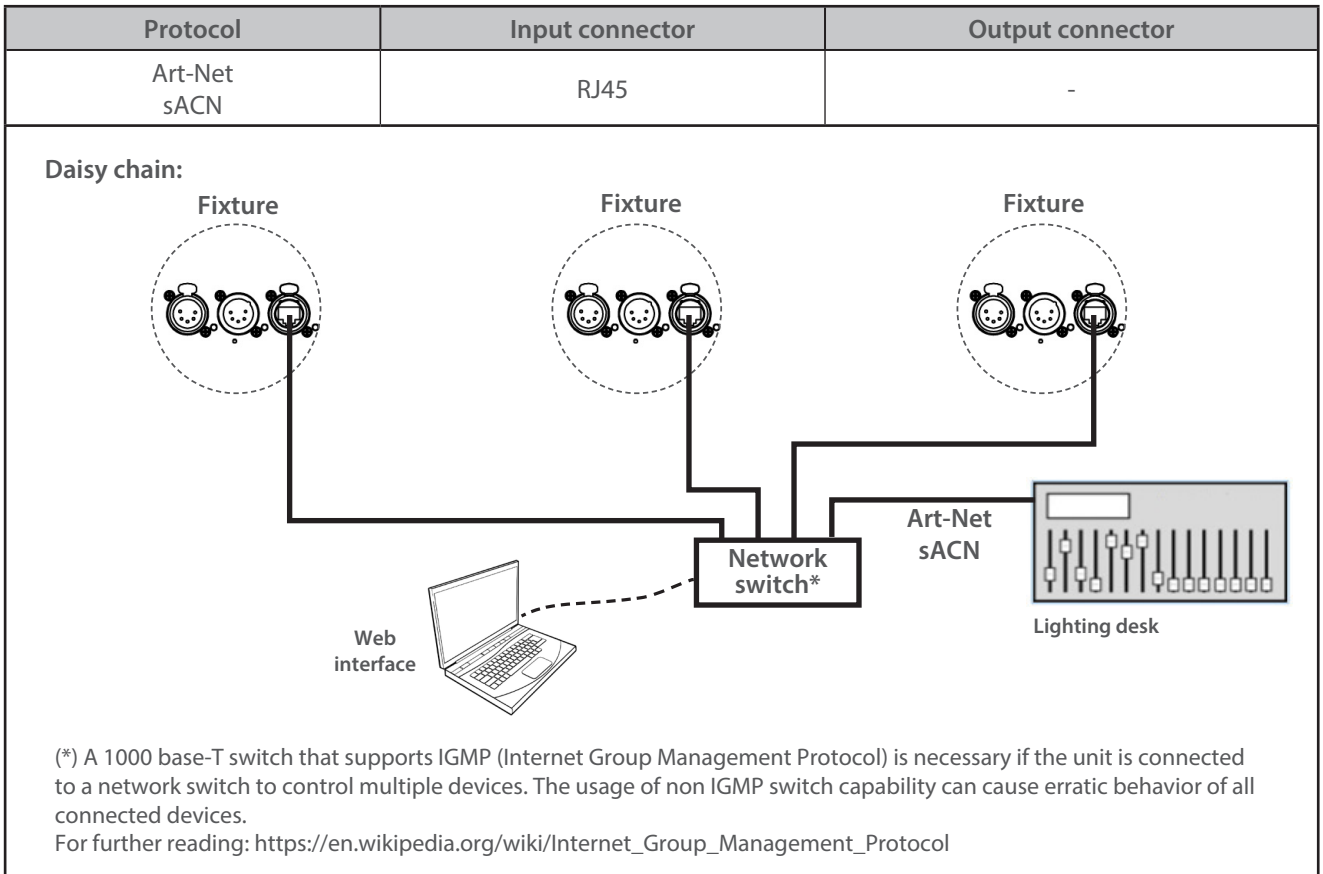

3.3.3 Ethernet / DMX node

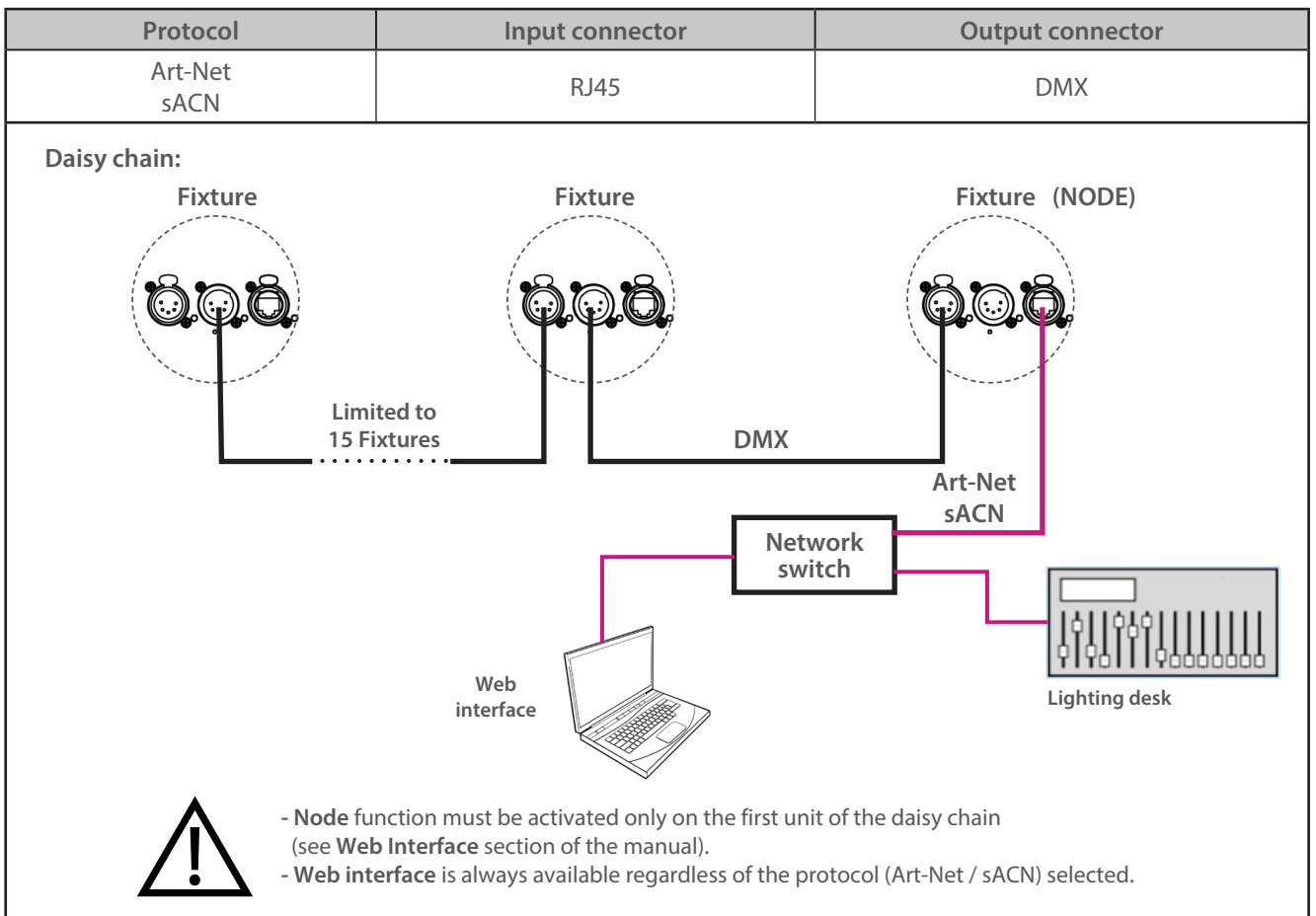

3.4 Accessories

3.4.1 Front filter holder

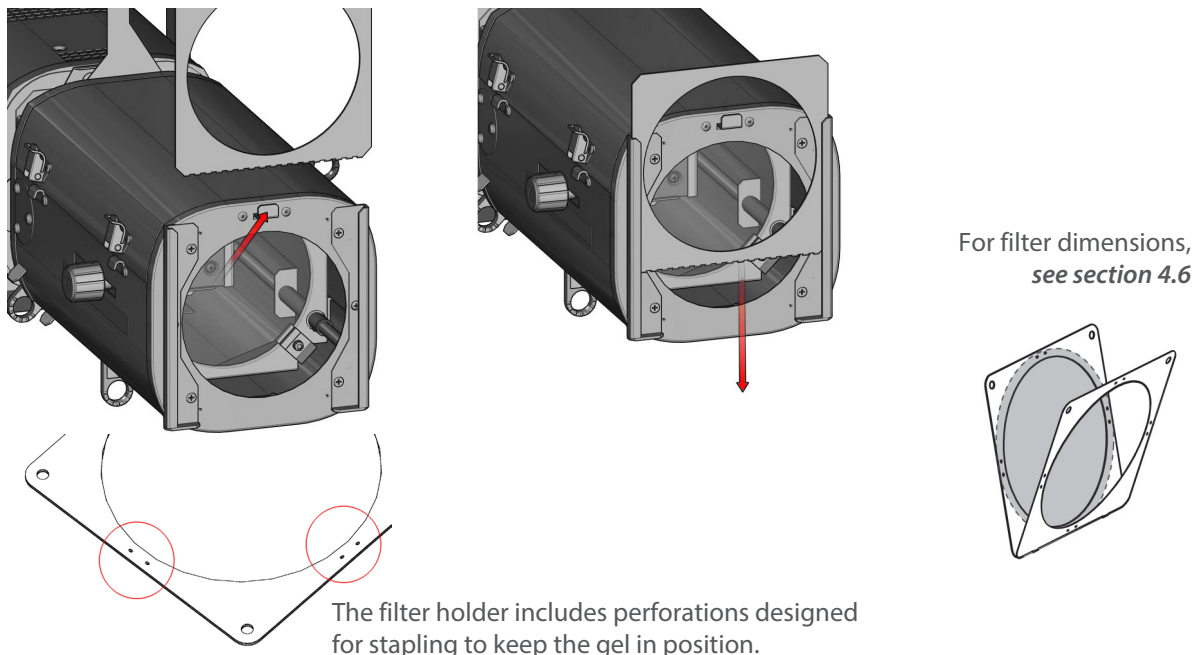

3.4.2 Double-condenser set

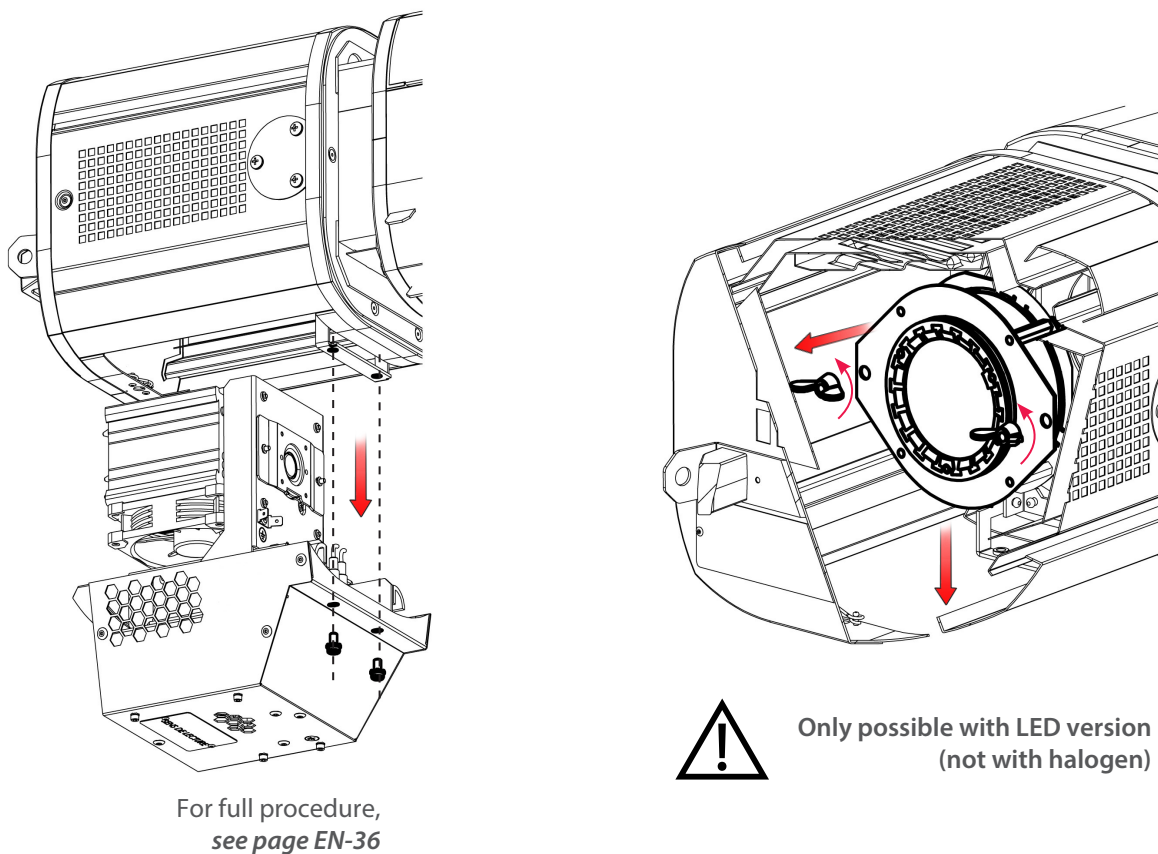

3.4.3 Internal filter holder

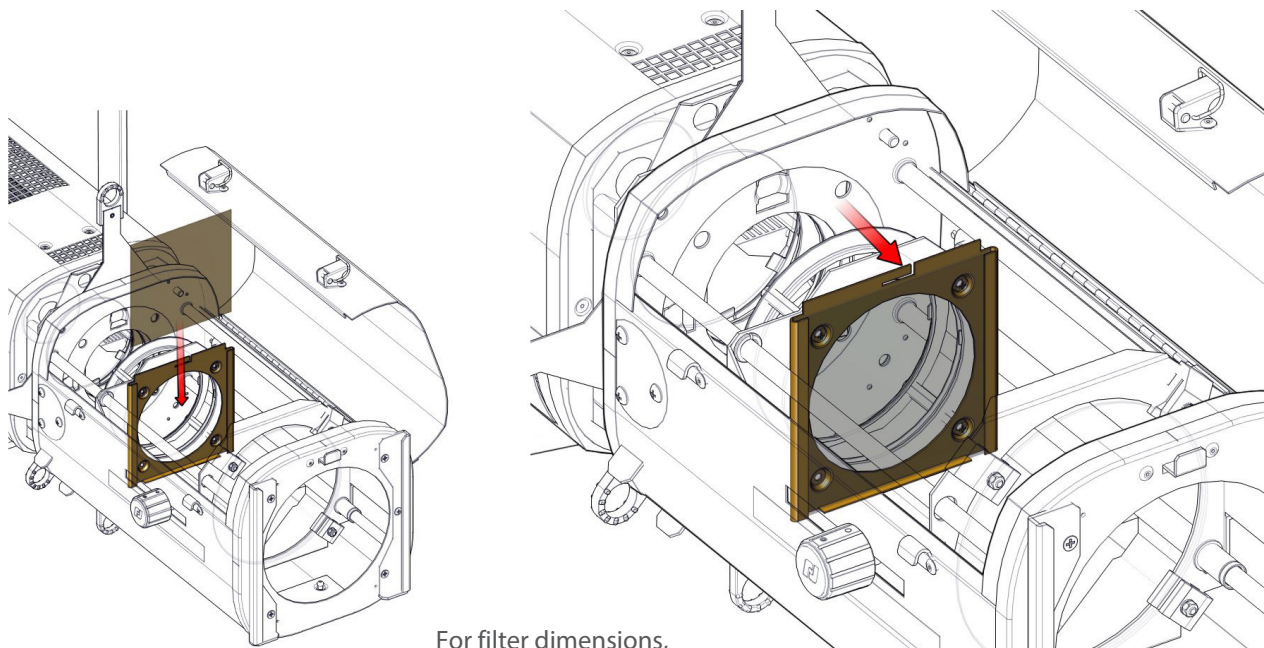

For filter dimensions,
see section 4.6

3.4.4 Gobo holder / Iris

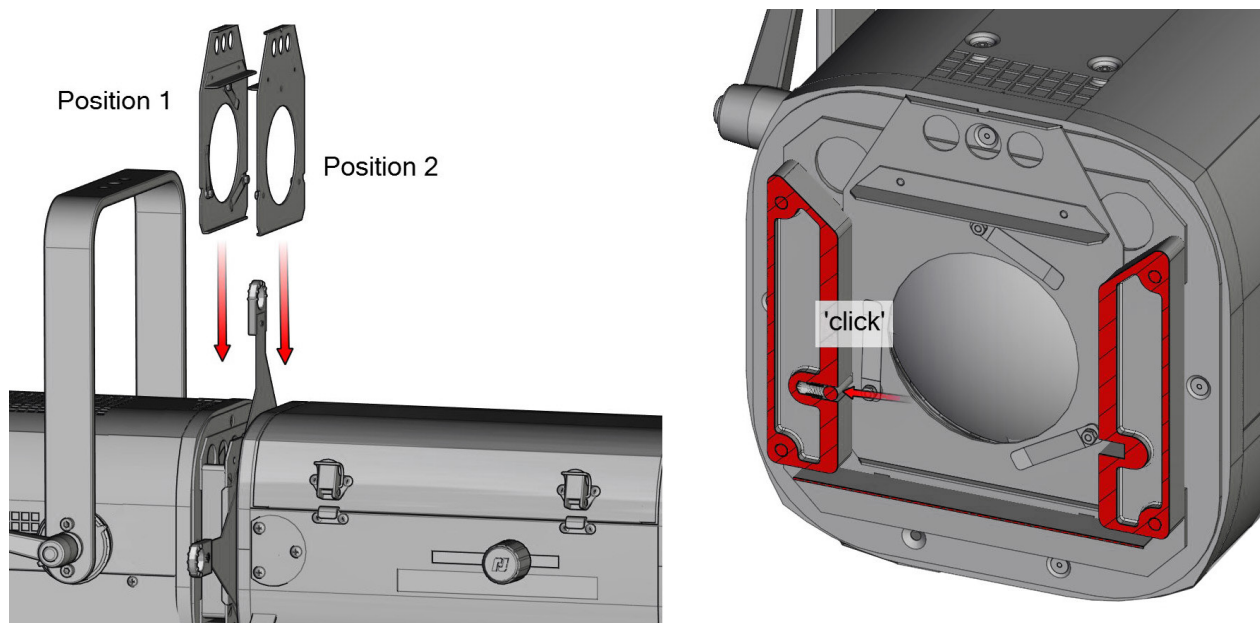

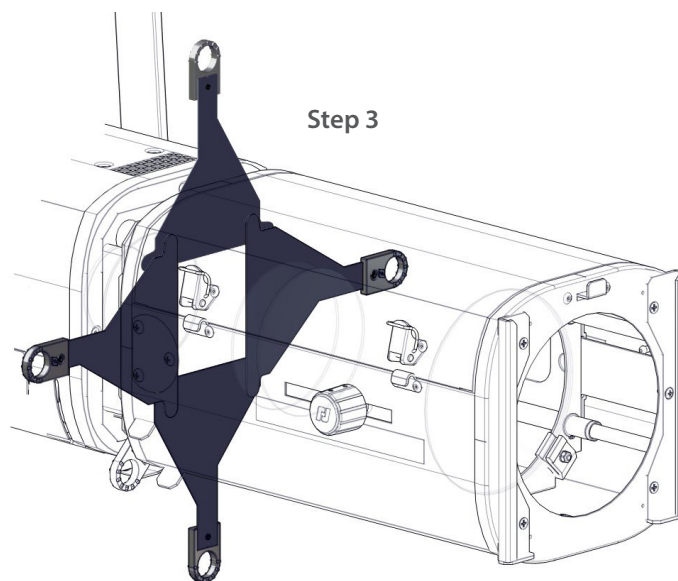
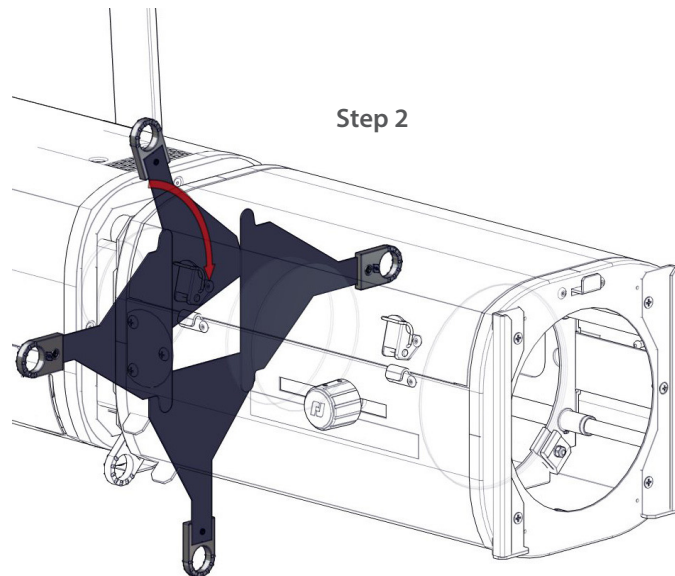
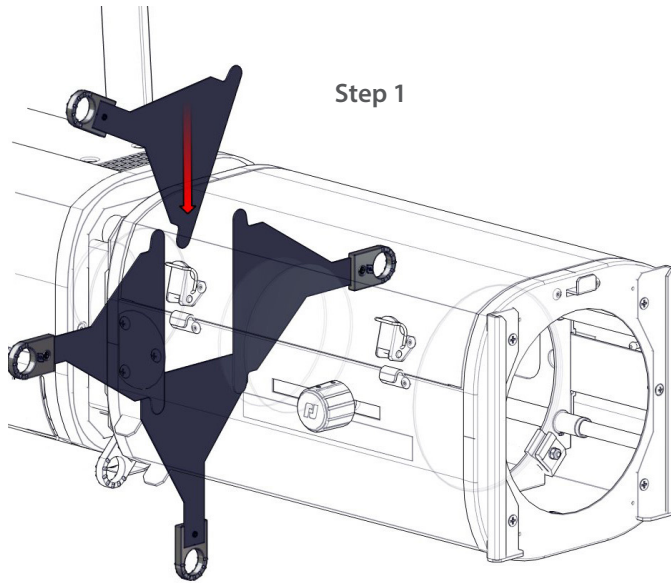

4.1 Light intensity

4.1.1 Range



4.1.2 Control

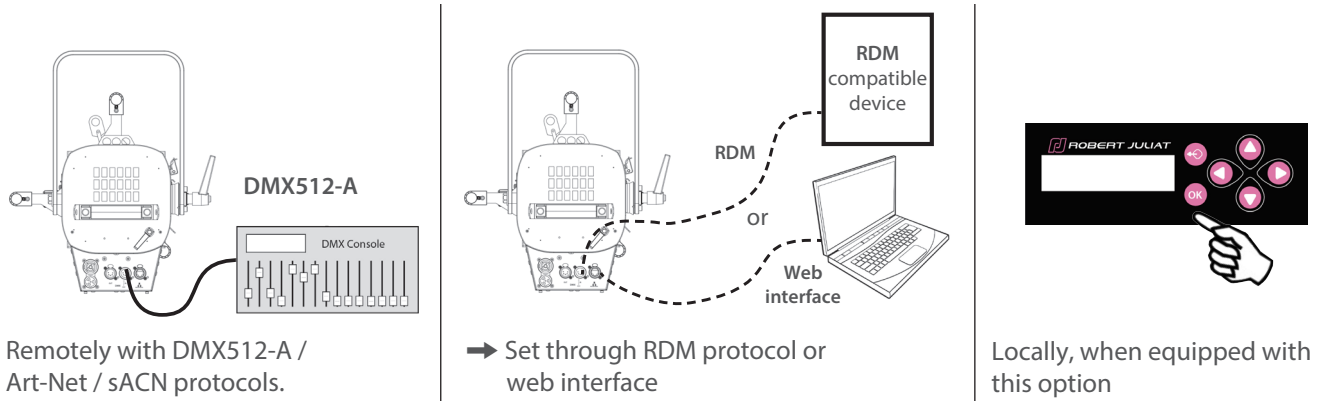

HTP mode (Highest Takes Precedence):
Light output is the highest value of DMX512 command or local control

Focus mode: when standby screen displayed,
Push Exit f<or 3 secs → Light output = 100% for 1 minute
2x times Exit → Light output = 0%

4.1.3 Parameters

4.1.3.1 Dimming resolution - DMX only

→ Set through RDM protocol, web interface or local control (option)

Resolution	DMX mode
8 bits – 255 steps	1 - 3
16 bits – 65 535 steps	2 - 4

4.1.3.2 Dimming curve

→ Set through RDM protocol, web interface or local control (option)

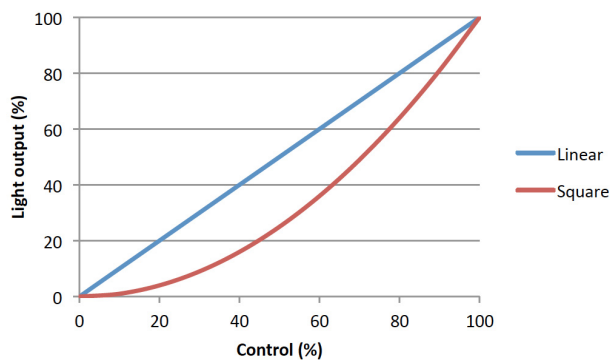

4.1.3.3 Set maximum position

➔ Set through RDM protocol, web interface or local control (option)

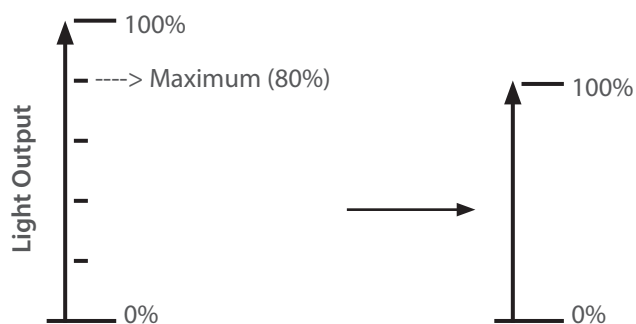

4.1.3.4 Dimming mode

➔ Set through RDM protocol, web interface or local control (option)

Mode	Result
Without PWM	Flicker-Free, perfect for filming
PWM 17 kHz	Good dimming quality (Default Value)
PWM 3,2 kHz	Very good dimming

4.2 Strobe

4.2.1 Range

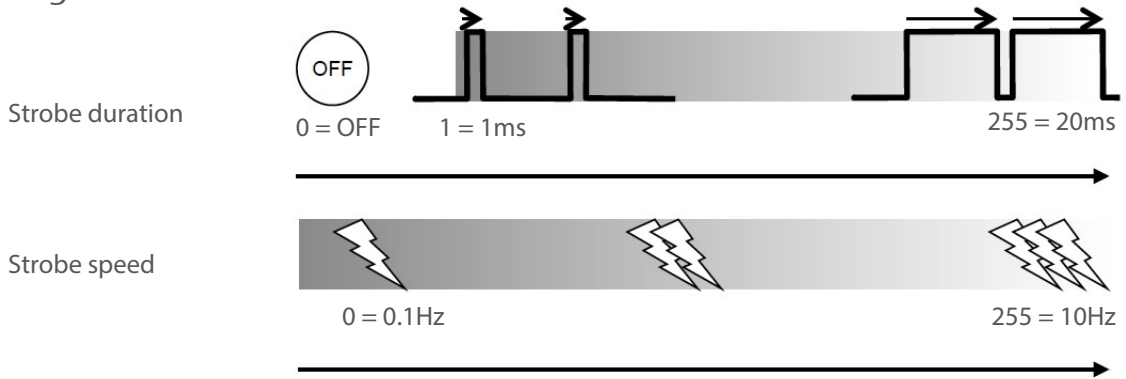

4.2.2 Control

➔ Remotely with DMX512-A / Art-Net / sACN protocols.
Mode 3 – 4

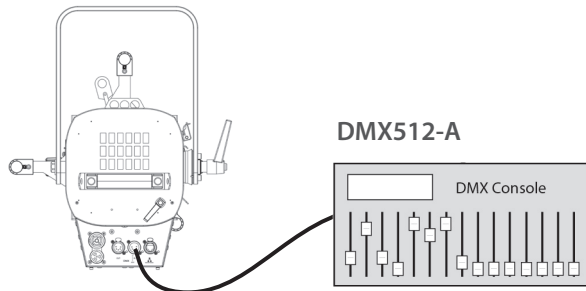

4.3 Response time

4.3.1 Range

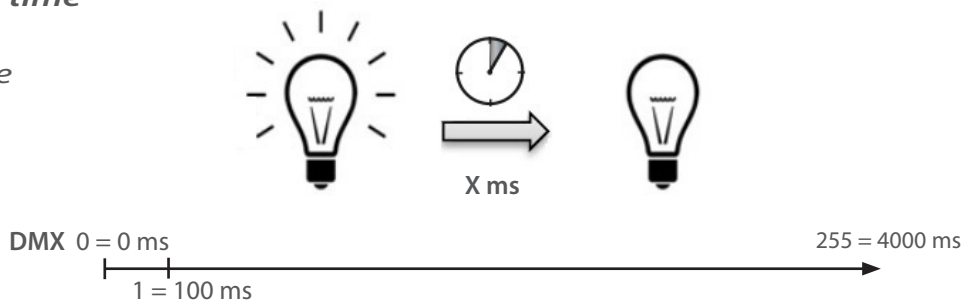

4.3.2 Control

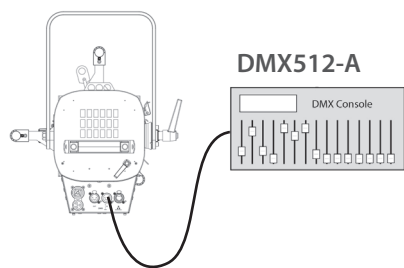

Remotely, with DMX512-A / Art-Net / sACN protocols
Mode 3 – 4 only

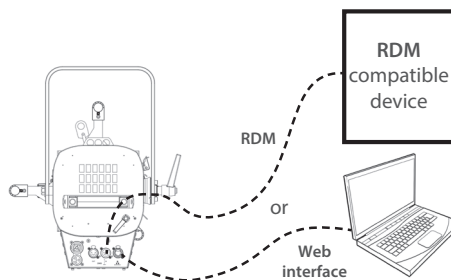

➔ Set through RDM protocol or web interface

Mode	Speed
NONE	OFF
SLOW	700 ms
MEDIUM	470 ms
FAST	350 ms
CUSTOM	0 - 4000 ms

Locally, when equipped with this option

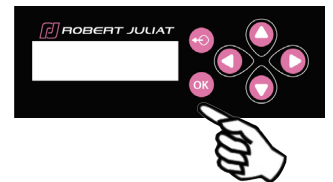

Only when no DMX detected :
➔ selection in SETUP/DIMMER/
RESPONSE TIME

Mode	Speed
NONE	OFF
SLOW	700 ms
MEDIUM	470 ms
FAST	350 ms
CUSTOM	0 - 4000 ms

4.4 Beam size adjustment

4.4.1 Range

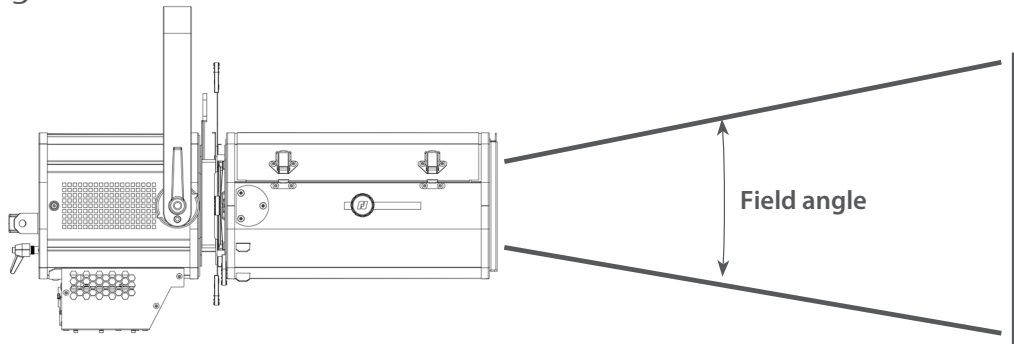

Model	Minimum angle	Maximum angle
653SX / 653CSX	28°	54°
654SX / 654CSX	16°	35°
651SX / 651CSX	11°	26°

4.4.2 Control

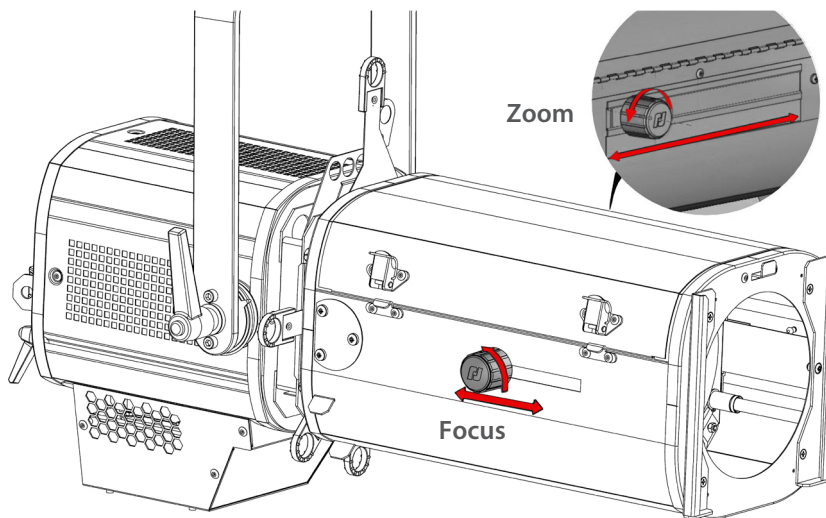

4.5 Orientation

4.5.1 Range

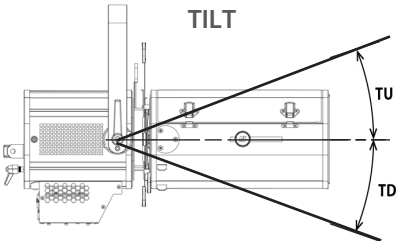
Function	Range
PAN	0 → 360°
TILT	 TU = 0 → 63° TD = 0 → 90°

4.5.2 Control

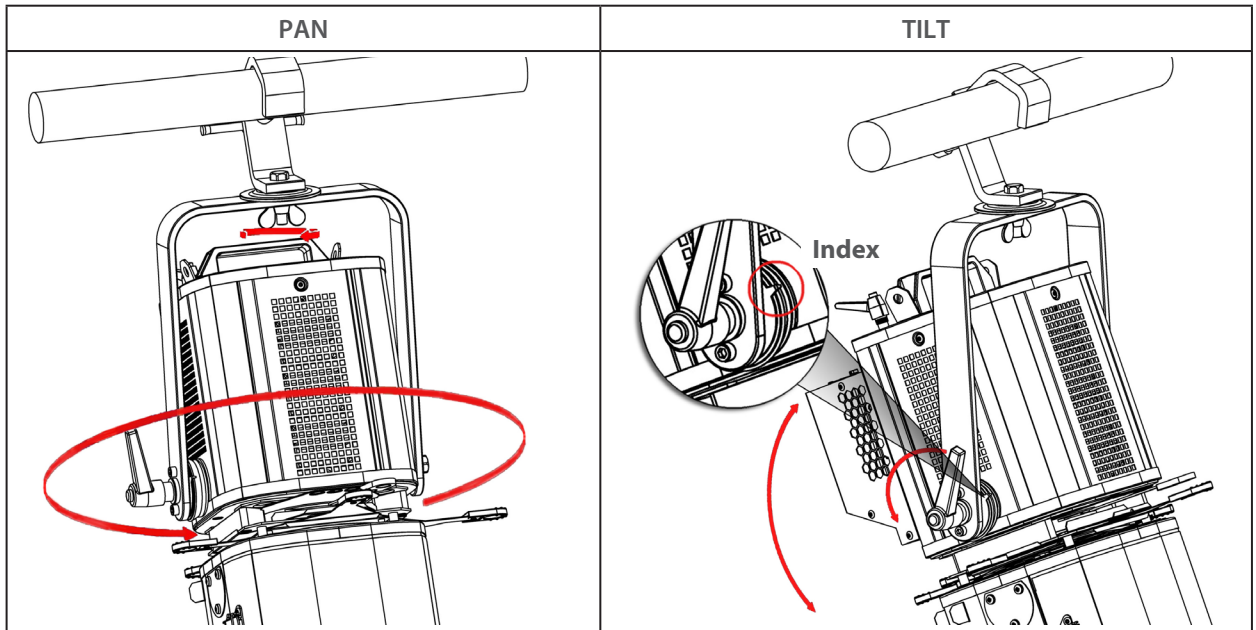

4.6 Colour

Fixed colour:

<p>Location</p>		
	<p>1. Front filter holder</p>	<p>2. Internal filter holder</p>
<p>Type</p>	<p>Standard coloured gel filter</p>	<p>Frosted or dichroic glass</p>
<p>Dimensions</p>		
<p>Installation</p>	<p>See 3.4.1</p>	<p>See 3.4.2</p>

4.7 Beam shaping

4.7.1 Range

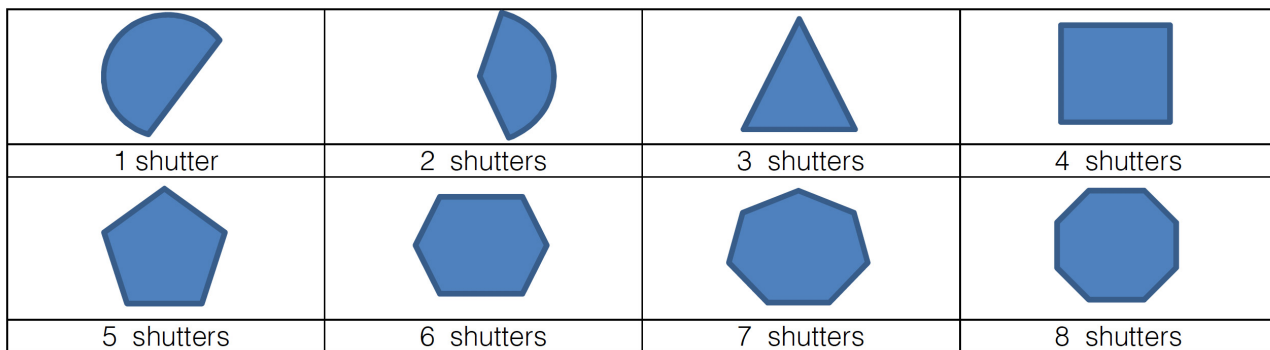
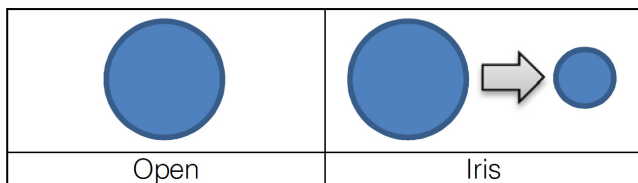

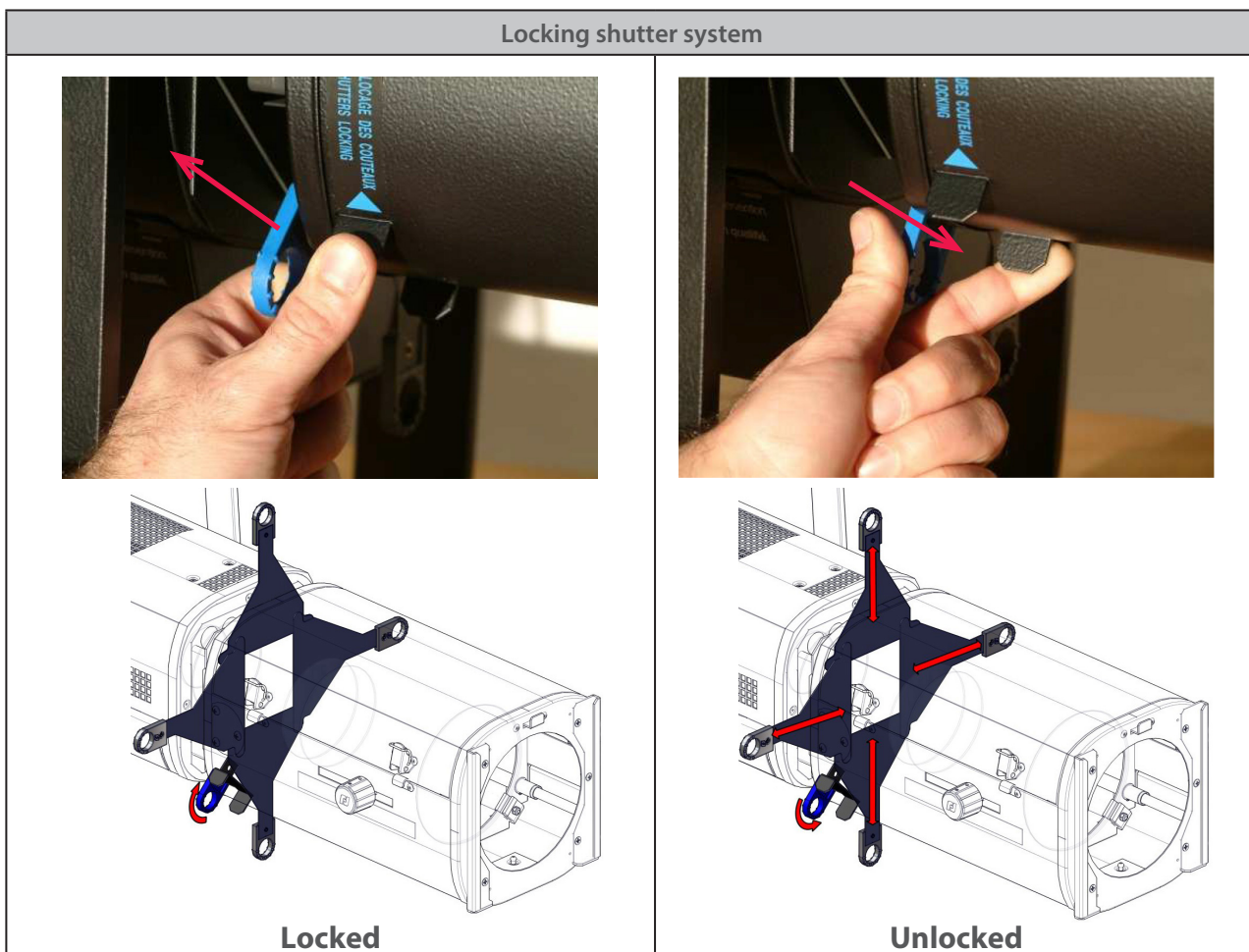

4.7.2 Control



See 3.4 Accessories for gobo, iris and additional shutters installation

4.8 Beam rotation

4.8.1 Range

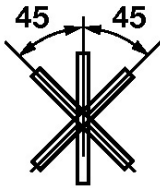
Function		Range
		
Gobo	Shutters	

4.8.2 Control

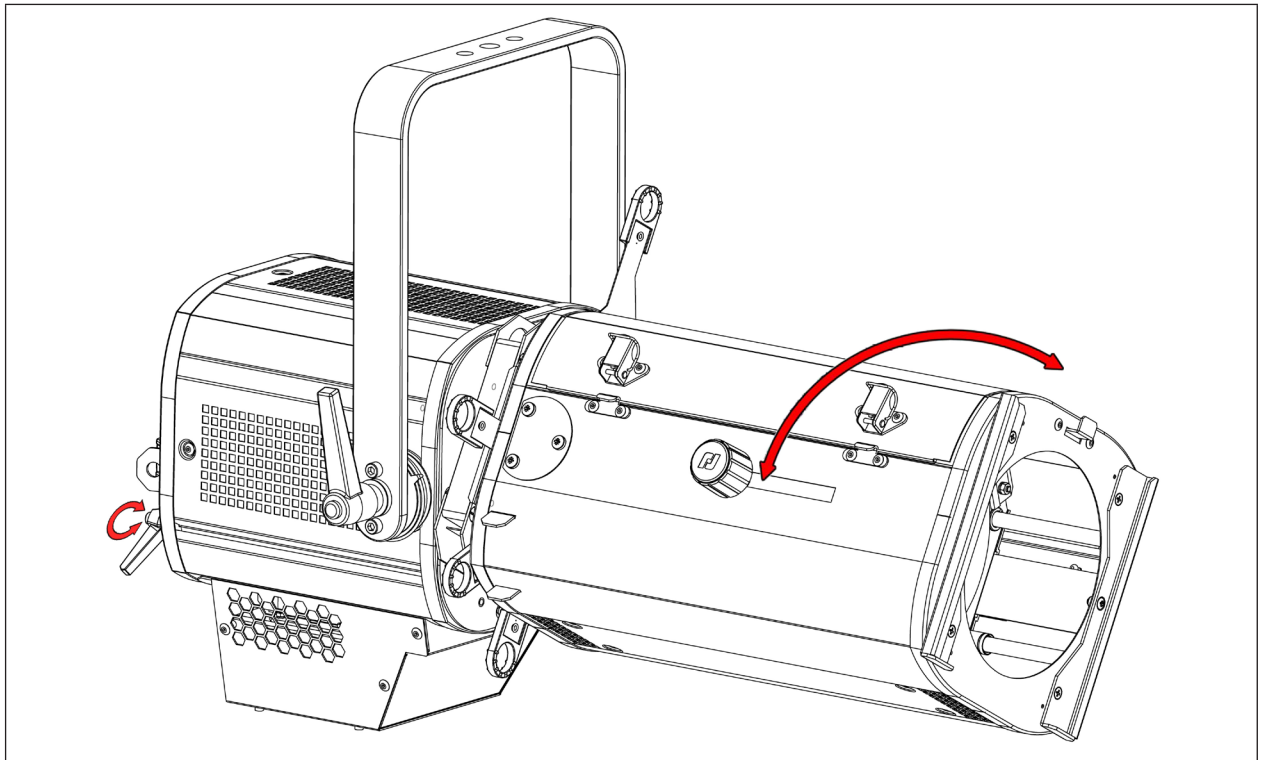

<p>Location</p>		
<p>Type</p>	<p>Metal / Glass</p>	
<p></p>	<p>A-size</p>	
<p>Installation</p>	<p>Position 1</p>	<p>Position 2</p>

5 Controls and parameters



5.1 Web interface

5.1.1 Control

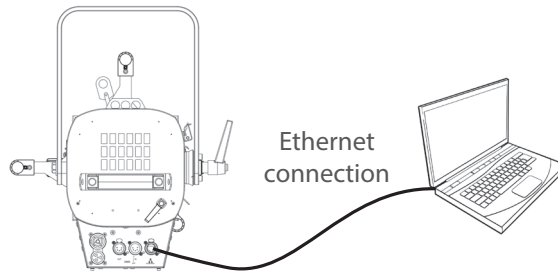

The fixture must be connected to a compatible network or directly to a computer using an ethernet cable.

5.1.2 Default IP address

By default :
DHCP = OFF
Address = 2.XXX.XXX.XXX
Mask = 255.0.0.0

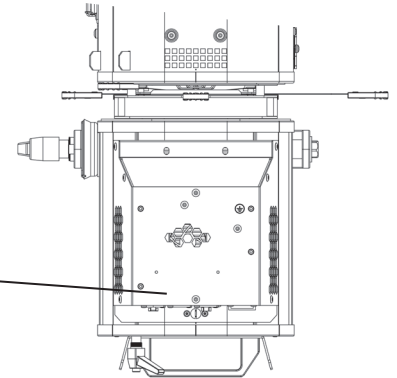

➔ If IP address unknown (due to a previous modification), a hard reset must be done (see 6.5 Factory defaults).

5.1.3 Network IP of the computer

The computer must be on the same network as the Sully fixture.

Please refer to your computer Operating System to change IPV4 parameters :

- **Microsoft Windows:**

<https://support.microsoft.com/en-us/windows/change-tcp-ip-settings-bd0a07af-15f5-cd6a-363f-ca2b6f391ace>

- **MAC OS:** <https://support.apple.com/en-gb/guide/mac-help/mchlp2718/10.15/mac/10.15>

1 - ADDRESS = 2.XXX.XXX.YYY with YYY \neq XXX

Do not use the same IP address as the Sully fixture

2 - MASK = 255.0.0.0

5.1.4 Connect to web interface

1 - Open a web browser (Microsoft Edge, Firefox, Apple Safari...)

2 - Enter the URL address of the Sully fixture: <http://2.XXX.XXX.XXX>

3 - All parameters can be now modified

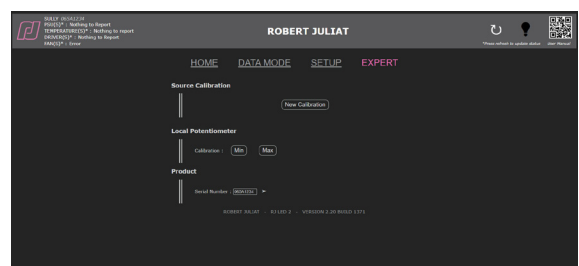
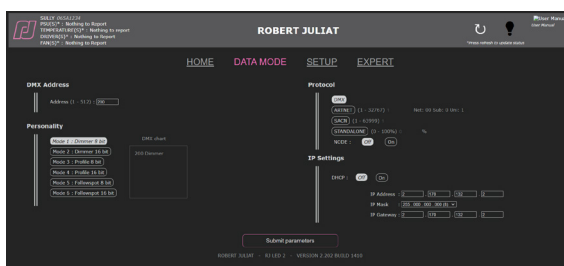
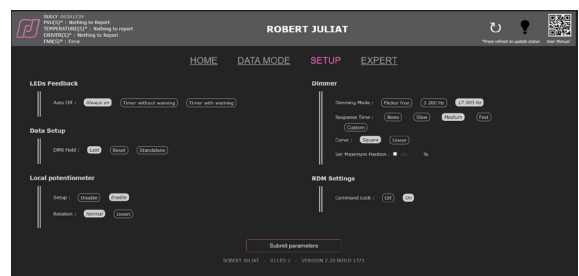
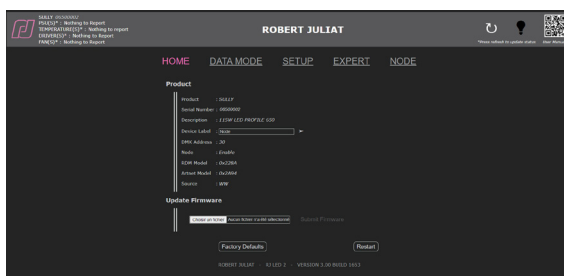



After updating your device with firmware V3.0, we strongly recommend that you update the source type (CCT) either to CW (Cold White) or WW (Warm White) by following the procedure described in the section below: **5.1.5 CCT selection**

5.1.5 CCT selection

Until now, the CCT of the LED source was not taken into account. From V3.0, your device will be automatically recognized as CW or WW source.

Devices shipped with firmware prior to V3.0 do not have a designated CCT. After updating to V3.0, it is highly recommended to specify the CCT of your device. For this you will have to stay on the Web Page that you used for the update.

In the **Source** section of the HOME tab, the CCT of your device is indicated.

- If "unknown", please select the CCT of your device and click on icon **CW** or **WW** then on the arrow **>**.

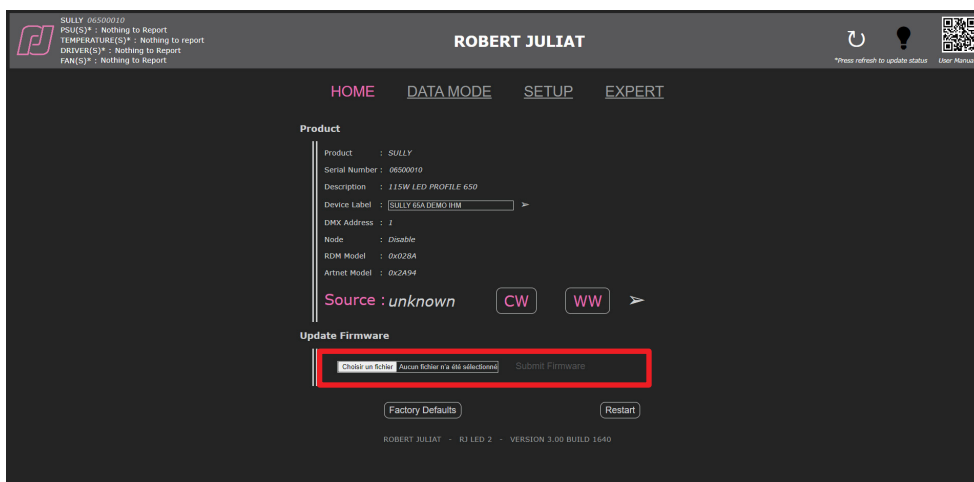

- Changing the source type changes the Model_ID as well. It is used in libraries to recognize devices automatically and for an Auto-Patch.
- If the source type has to be changed or in case of typing error, it will be always possible to change the source type in the Expert mode which is protected by a password.

5.2 LEDs Feedback

5.2.1 Trouble shooting

• During unit initialisation (power up) – up to 5 seconds:

1 DMX OUT	2 DMX IN	3 Network	Description
Ⓟ	Ⓟ	Ⓟ	Unit OFF
Ⓡ	Ⓡ	Ⓡ	Unit error
Ⓢ	Ⓢ	Ⓢ	Unit has been reset successfully
Ⓟ	Ⓟ	Ⓡ or Ⓢ or Ⓟ	RDM protocol activated

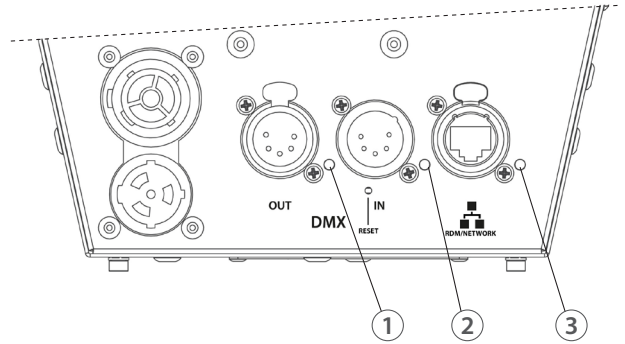

• After initialisation - Node mode "OFF":

1 DMX OUT	2 DMX IN	3 Network	Description
Ⓟ	Ⓟ	Ⓟ	Display auto-off
Ⓟ	Ⓢ	Ⓡ	No ethernet
Ⓟ		Ⓢ	Ethernet detected (link)
Ⓟ		Ⓟ	Ethernet detected + data
Ⓟ	Ⓟ	Ⓡ	No ethernet
Ⓟ		Ⓢ	Ethernet detected (link)
Ⓟ		Ⓟ	Ethernet detected + data
Ⓟ	Ⓡ	Ⓡ	No ethernet
Ⓟ		Ⓢ	Ethernet detected (link)
Ⓟ		Ⓟ	Ethernet detected + data
Ⓡ	Ⓡ	Ⓡ	Unit error

• After initialisation - Node mode "ON":

1 DMX OUT	2 DMX IN	3 Network	Description
Ⓟ	Ⓟ	Ⓟ	Display auto-off
Ⓢ	Ⓢ	Ⓡ	No ethernet
		Ⓢ	Ethernet detected (link)
		Ⓟ	Ethernet detected + data
Ⓟ	Ⓟ	Ⓡ	No ethernet
		Ⓢ	Ethernet detected (link)
		Ⓟ	Ethernet detected + data
Ⓡ	Ⓡ	Ⓡ	No ethernet
		Ⓢ	Ethernet detected (link)
		Ⓟ	Ethernet detected + data
Ⓡ	Ⓡ	Ⓡ	Unit error

5.2.2 Parameters

5.2.2.1 Intensity

➔ Set through RDM protocol, web interface or local control (option)

Mode	Description
Display level	Adjust the intensity of the feedback LEDs

5.2.2.2 Auto-OFF

➔ Set through RDM protocol, web interface or local control (option)

Mode	Description
Always ON	Feedback LED, always ON
Timer without warning	Feedback LED OFF after 20 seconds
Timer with warning	Feedback LED OFF after 20 seconds, ON, if warning information occurs

5.3.1 Protocol

E1.11 – 2008, USITT DMX512-A

5.3.2 Configuration

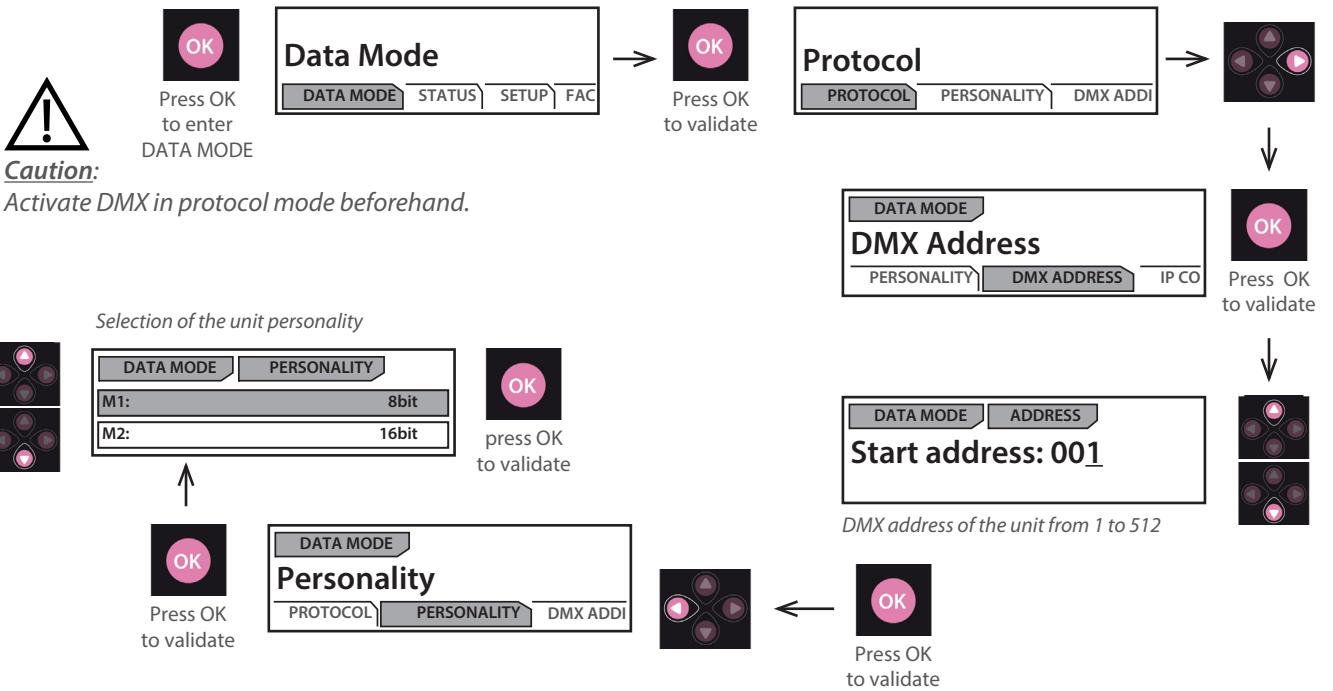
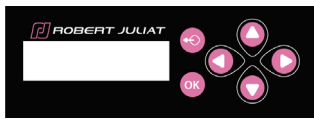
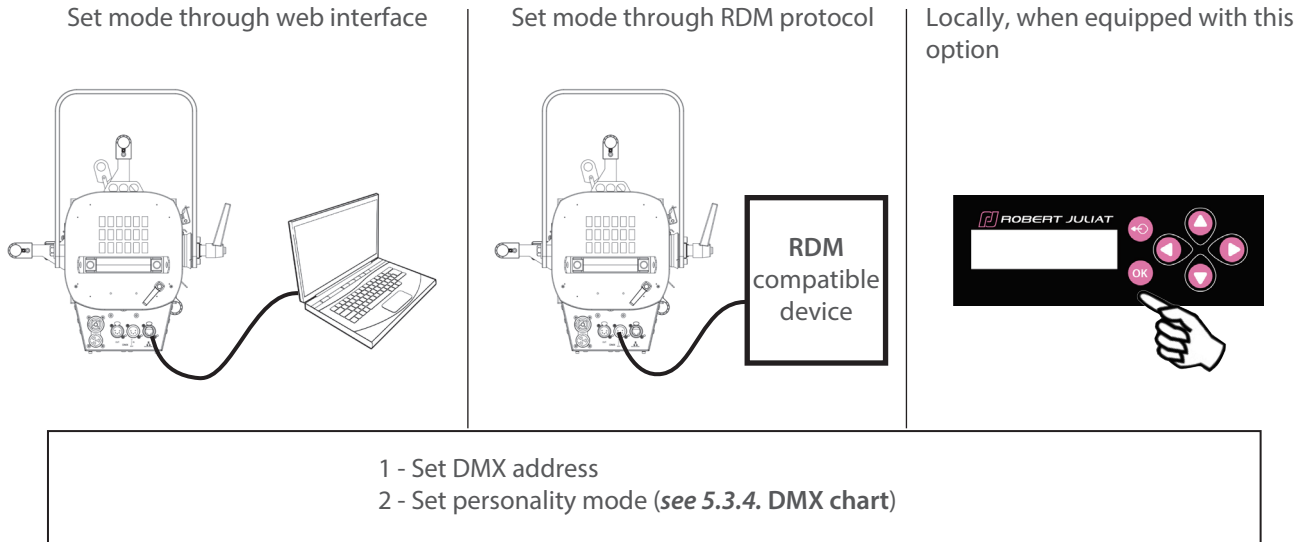

5.3.3 Parameters

5.3.3.1 DMX Hold

→ Set through RDM protocol, web interface or local control (option)

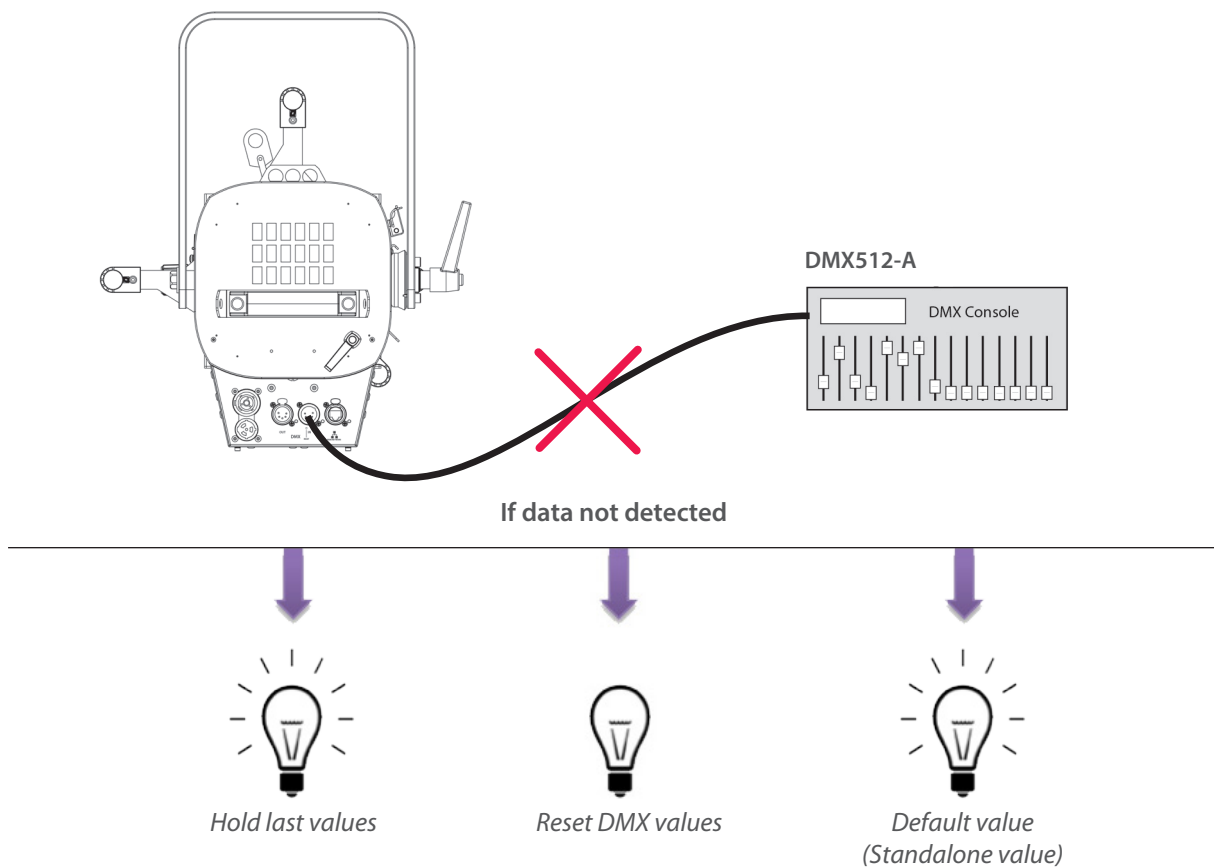

5.3.4 DMX chart

DMX Channel	Mode 1: Dimmer8B	Mode 2: Dimmer16B	Mode 3: Profile8B	Mode 4: Profile16b
1	Dimmer	Dimmer	Dimmer	Dimmer
2		Dimmer fine	Strobe duration	Dimmer fine
3			Strobe speed	Strobe duration
4			Response time	Strobe speed
5			Control mode	Response time
6				Control mode

5.3.5 DMX ranges

5.3.5.1 Strobe duration

Range min	Range max	Function
0	0	Strobe OFF
1	255	Strobe ON - 1 ms → 20 ms

5.3.5.2 Strobe speed

Range min	Range max	Function
0	255	Frequency: 0,1 Hz → 10 Hz

5.3.5.3 Response time

Range min	Range max	Function
0	0	OFF
1	255	Response time: 0,1 s → 4 s

5.3.5.4 Control mode*

Range min	Range max	Function	
		By default	If activated in web interface/RDM
0	0	-	-
1	10	-	RDM OFF
11	20	-	RDM ON
21	30	-	RESET DEVICE

(*) Function activated after 5 seconds - needs to go back to zero to activate second function.

5.4 RDM remote control

5.4.1 Protocol

ANSI E1.20 – 2010 / ANSI E1.37 - 1

For more information about RDM protocol: <http://www.rdmprotocol.org/>

5.4.2 Functions

PID	Function description	115W LED PROFILE			V3	
		Get	Set	Queued Message		
Network Management						
00	01	DISCOVERY_UNIQUE_BRANCH				X
00	02	DISCOVERY_MUTE		X		X
00	03	DISCOVERY_UNMUTE		X		X
00	15	COMMUNICATION_STATUS	X	X		X
Status Collection						
00	20	QUEUED_MESSAGE	X			X
00	30	STATUS_MESSAGES	X			X
00	31	STATUS_ID_DESCRIPTION	X			X
00	32	CLEAR_STATUS_ID		X		X
RDM Information						
00	50	SUPPORTED_PARAMETERS	X			X
00	51	PARAMETER_DESCRIPTION	X			X
Product Information						
00	60	DEVICE_INFO	X		X	X
00	70	PRODUCT_DETAIL_ID_LIST	X			X
00	80	DEVICE_MODEL_DESCRIPTION	X			X
00	81	MANUFACTURER_LABEL	X			X
00	82	DEVICE_LABEL	X	X	X	X
00	90	FACTORY_DEFAULTS	X	X	X	X
00	C0	SOFTWARE_VERSION_LABEL	X		X	X
00	C2	BOOT_SOFTWARE_VERSION_LABEL	X			X
DMX512 Setup						
00	E0	DMX512_PERSONALITY	X	X	X	X
00	E1	DMX512_PERSONALITY_DESCRIPTION	X			X
00	F0	DMX512_STARTING_ADDRESS	X	X	X	X
01	20	SLOT_INFO	X			X
01	21	SLOT_DESCRIPTION	X			X
Sensors						
02	00	SENSOR_DEFINITION	X			X
02	01	SENSOR_VALUE	X			X
DMX Settings						
03	40	DIMMER_INFO	X			X
03	42	MAXIMUM_LEVEL	X	X	X	X
03	43	CURVE	X	X	X	X
03	44	CURVE_DESCRIPTION	X			X
03	45	OUTPUT_RESPONSE_TIME	X	X	X	X
03	46	OUTPUT_RESPONSE_TIME_DESCRIPTION	X			X
03	47	MODULATION_FREQUENCY	X	X	X	X
03	48	MODULATION_FREQUENCY_DESCRIPTION	X			X
Power / Lamp Settings						
04	00	DEVICE_HOURS	X			X
04	01	LAMP_HOURS	X	X		X
Display Settings						
05	01	DISPLAY_LEVEL	X	X	X	X

PID	Function description	115W LED PROFILE			V3	
		Get	Set	Queued Message		
Control						
10	00	IDENTIFY_DEVICE	X	X		X
10	01	RESET_DEVICE		X	X	X
10	20	PERFORM_SELFTEST	X	X		X
10	21	SELF_TEST_DESCRIPTION				X
RDMnet Management						
07	00	LIST_INTERFACES	X			X
07	01	INTERFACE_LABEL	X			X
07	02	INTERFACE_HARDWARE_ADRESS_TYPE1	X			X
07	03	IPV4_DHCP_MODE	X	X	X	X
07	05	IPV4_CURRENT_ADDRESS	X		X	X
07	06	IPV4_STATIC_ADDRESS	X	X		X
07	08	INTERFACE_RELEASE_DHCP		X		
07	09	INTERFACE_APPLY_CONFIGURATION		X		X
07	0A	IPV4_DEFAULT_ROUTE	X	X	X	X
07	0B	DNS_IPV4_NAME_SERVER	X	X	X	X
07	0C	DNS_HOSTNAME	X	X		
PID Manufacturer						
85	58	SELFTEST_RESULT	X			X
85	59	CURRENT_IP_ADDRESS	X		X	X
85	5A	CURRENT_NETMASK	X		X	X
85	5B	CURRENT_DRIVER_STATUS	X		X	X
85	5C	CUSTOM_RESPONSE_TIME_DESCRIPTION	X			X
85	5D	CUSTOM_RESPONSE_TIME_VALUE	X	X	X	X
85	60	DATA_MODE_DESCRIPTION	X			X
85	61	DATA_MODE_VALUE	X	X	X	X
85	62	STANDALONE_VALUE_DESCRIPTION	X			X
85	63	STANDALONE_VALUE	X	X	X	X
85	64	SACN_UNIVERSE_VALUE_DESCRIPTION	X			X
85	65	SACN_UNIVERSE_VALUE	X	X	X	X
85	66	ARTNET_UNIVERSE_VALUE_DESCRIPTION	X			X
85	67	ARTNET_UNIVERSE_VALUE	X	X	X	X
85	68	SERIAL_DESCRIPTION	X			X
85	69	SERIAL	X	X		X
85	6A	DMX_HOLD_DESCRIPTION	X			X
85	6B	DMX_HOLD	X	X	X	X
85	6C	COMMAND_LOCK_DESCRIPTION	X			X
85	6D	COMMAND_LOCK_VALUE	X	X	X	X
85	6E	DRIVER_CALIBRATE_DESCRIPTION	X			X
85	6F	DRIVER_CALIBRATE_VALUE	X	X	X	X
85	6E	DRIVER_CALIBRATE_DESCRIPTION	X			X
85	6F	DRIVER_CALIBRATE_VALUE	X	X		X
85	70	NODE_DESCRIPTION	X			X
85	71	NODE_VALUE	X	X		X

5.5.1 Protocol

Artistic Licence Art-Net v3.

For more information about Art-Net protocol: <http://art-net.org.uk/>

5.5.2 Configuration

Set mode through web interface
(see 5.1 Web interface)

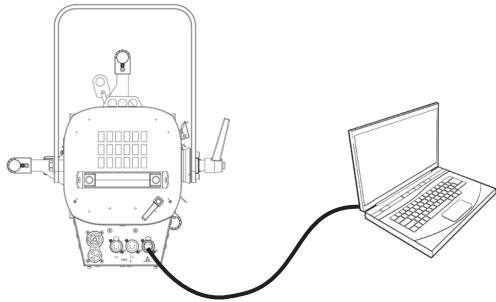

Locally, when equipped with this option

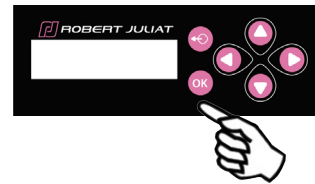

- 1 - If necessary, change IP settings
- 2 - Set Art-Net Universe
- 3 - Set DMX address
- 2 - Set personality mode (see 5.3.4. DMX chart)

5.6.1 Protocol

ANSI E1.31 – 2009 sACN (Streaming-ACN)

5.6.2 Configuration

Set mode through web interface
(see 5.1 Web interface)

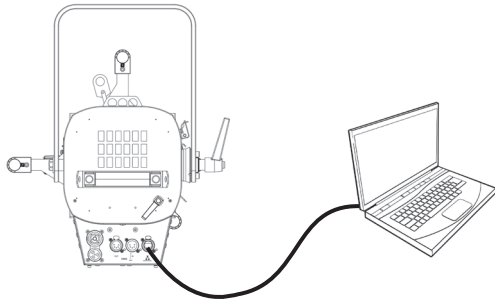

Locally, when equipped with this option

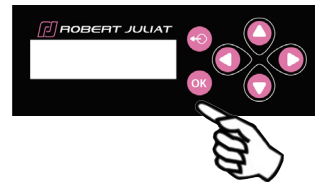

- 1 - If necessary, change IP settings
- 2 - Set sACN universe
- 3 - Set DMX address
- 2 - Set personality mode (see 5.3.4. DMX chart)

5.6.3 Local set-up

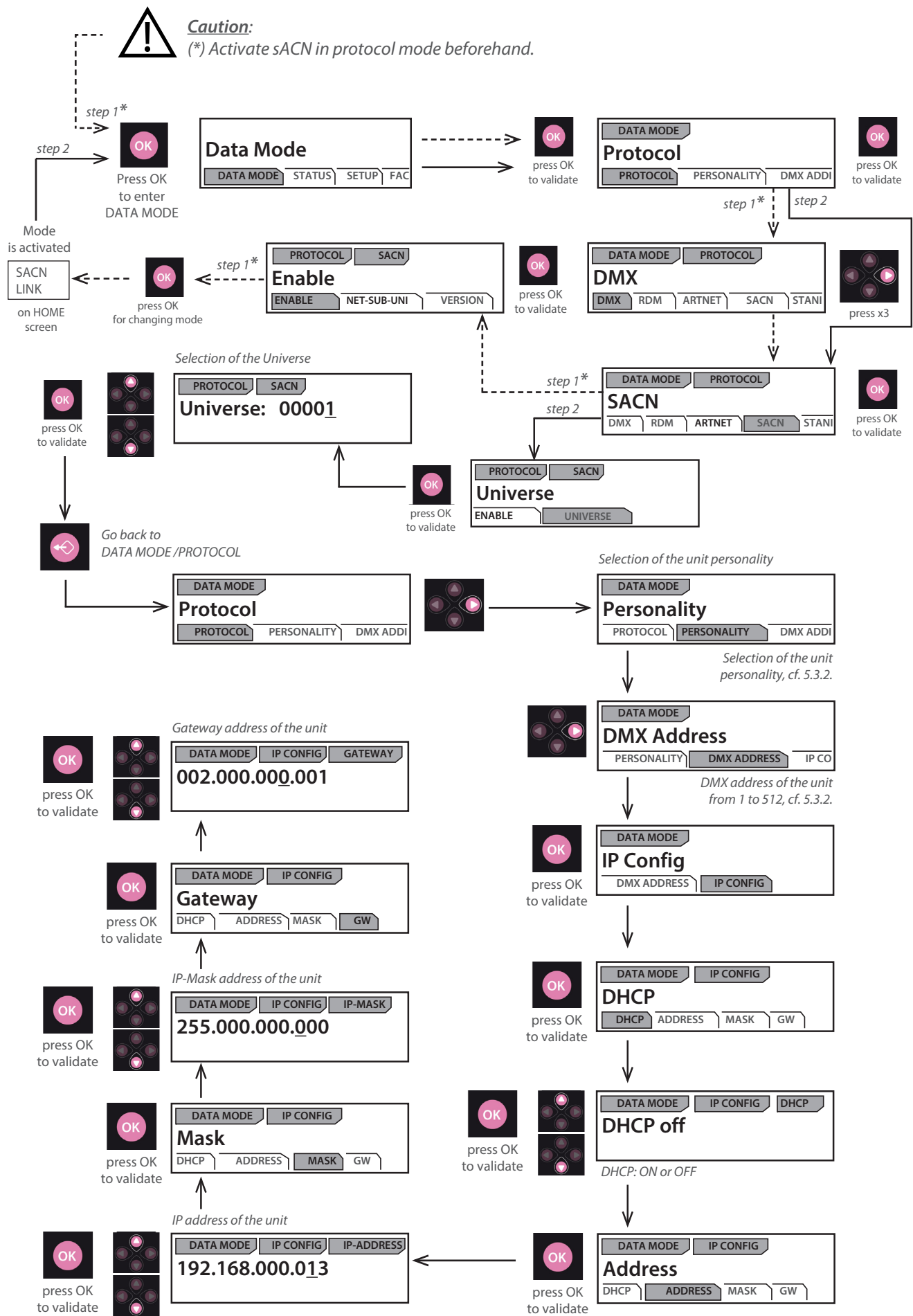

5.7.1 Display

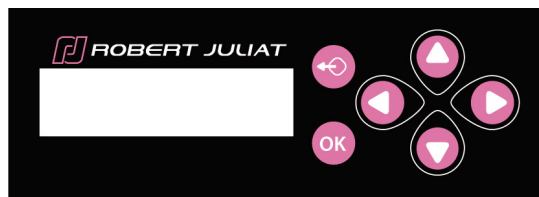

Function	
	Exit the current menu option and/or go back
	Press for 3 secs to enter Focus mode
	Enter the current menu option and/or valid
	Scroll through menus and/or Increase data value
	Scroll through menus and/or Decrease data value
	Scroll through menus and/or Increase data value
	Scroll through menus and/or Decrease data value

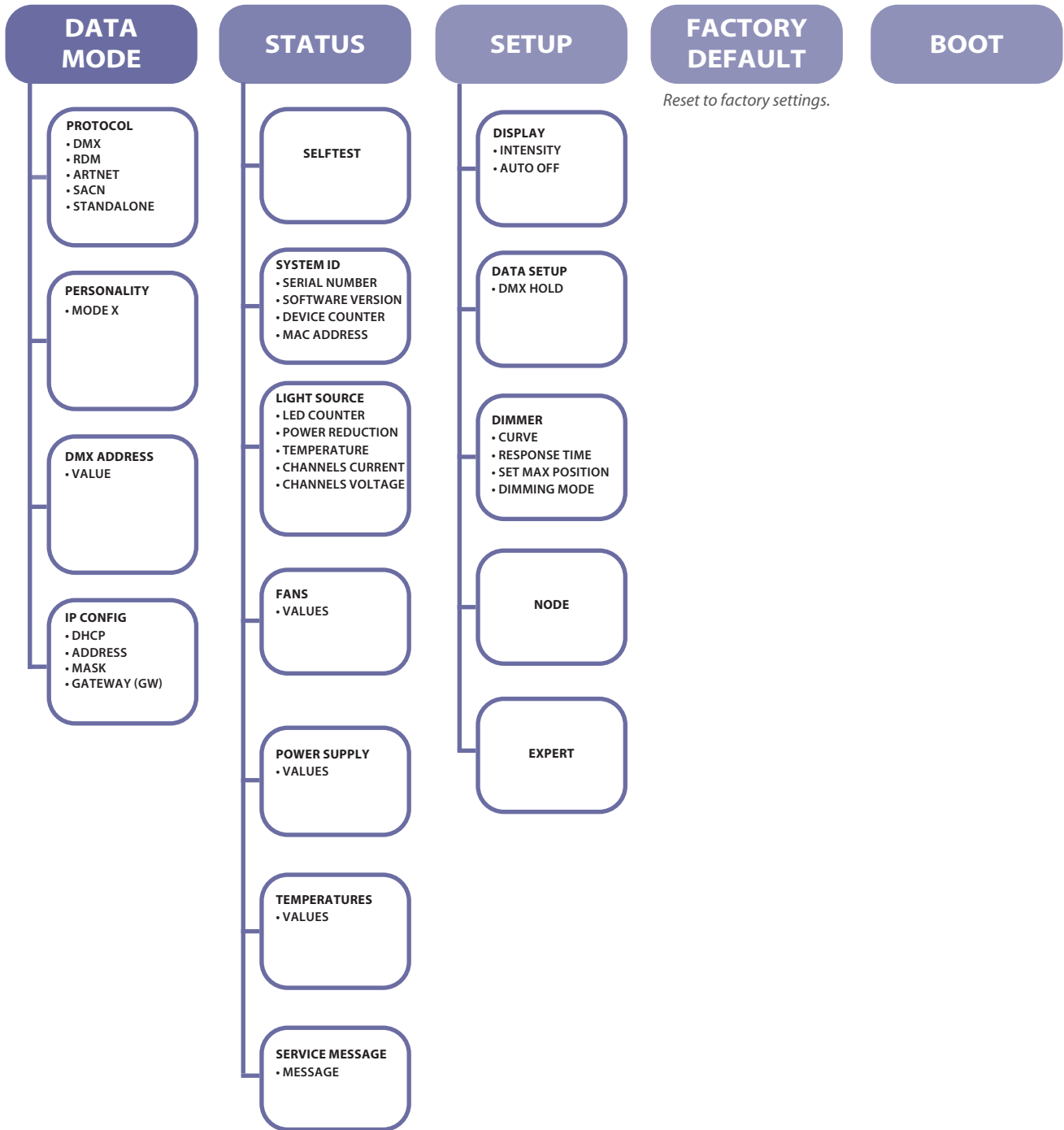

→ Selection in *SETUP/DISPLAY MODE* menu

Display	Mode	Description
	Always ON	Main display (home screen) always ON
	Intensity	Adjust the intensity of the screen <i>To change value, press buttons :</i> press OK to validate
	Auto-OFF	Main display OFF after 20 seconds

6.1 Preventive maintenance

6.1.1 Frequency

General maintenance should be performed at least once a year or more frequently if the equipment is operated in adverse conditions (smoke, heat, humidity, touring, etc.).

6.1.2 General cleaning

Remove dust from the unit.

Front glasses can be cleaned with solutions containing alcohol.

6.1.3 General visual check

- No trace of heat.
- No loose contacts.
- No missing parts.
- Tighten mechanical assemblies (screws, bolts and nuts, etc.).

6.1.4 LED source



- Do not touch the surface of the LED source (no contact with your hands or any tools).
- Do not put compressed air directly on the source.
- Contact a certified RJ distributor in case of residuals or other objects located on the surface of the LED source.

6.1.5 Optics

Only use solutions containing alcohol to clean optical parts (lenses).

- To clean the optical parts, use a soft cloth in combination with distilled water or isopropyl alcohol recommended for coated optics. Do not use any cleaning product that contains solvents or abrasives, as these can cause surface damage.
- Dry with a soft lint-free cloth.

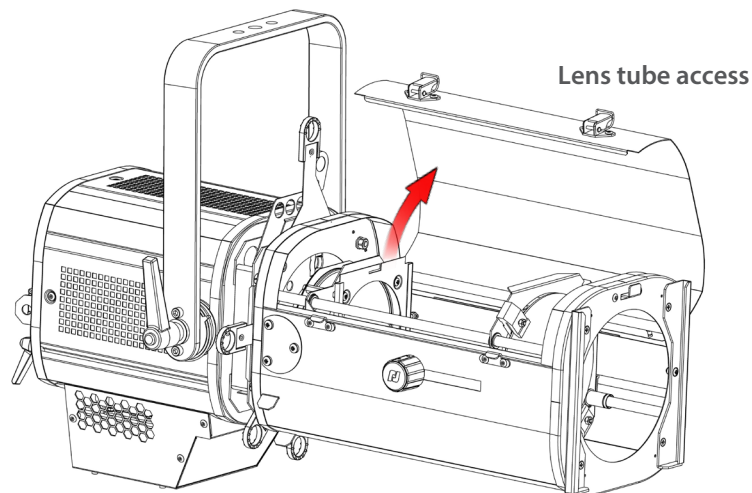

6.1.6 LED house cleaning

Inner parts & lens holder access:

- To clean the optical parts, use a soft cloth in combination with distilled water or isopropyl alcohol recommended for coated optics. Do not use any cleaning product that contains solvents or abrasives, as these can cause surface damage.
- Dry with a soft lint-free cloth.
- The double condenser system (aspheric and biconvex lenses) can easily be removed, without tools, by loosening the two wing nuts. The complete holder can then be removed for cleaning.

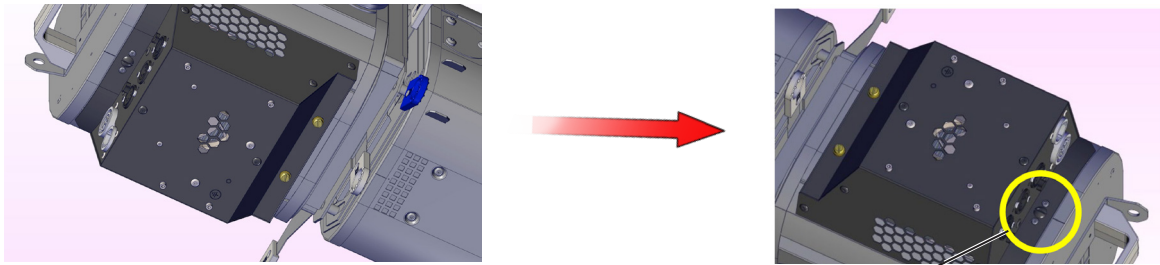

How to remove the Sully LED compartment for cleaning:

1. We recommend you place your luminaire on a flat clean surface.
Disconnect from the mains before servicing.
2. Unlock the quarter turn screw with a flat screwdriver.
3. Remove the two screws with a flat screwdriver.
4. Slightly slide out the LED compartment and remove the earth attachment before removing it completely from it's housing.
5. Carefully place the LED compartment on a flat clean surface.

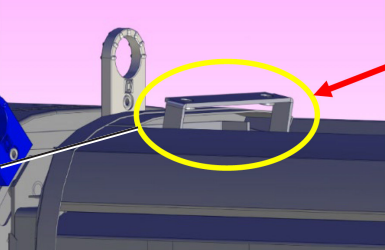
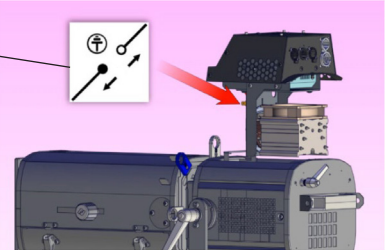
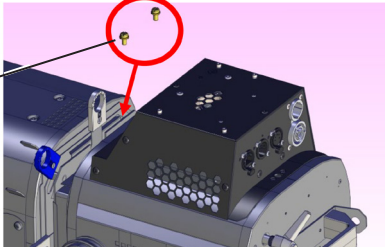

Sully LED compartment installation:

6. Extend the hinge to its maximum position to make it easily accessible. Insert the LED compartment into your luminaire, making sure it is positioned vertically to enable the LED compartment to enter the lamp house correctly.
7. Connect the ground connection (faston tab terminal) to the Sully LED compartment.
8. Once the LED compartment is fully inserted, remount tightly the two screws nearest the shutter gate. Re-tighten the quarter turn screw located at the back of the lamp base to lock the LED compartment securely into your luminaire.

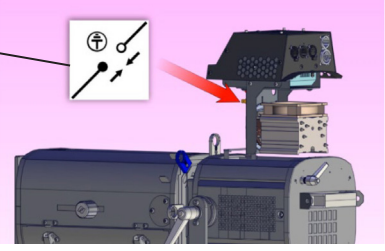

6.2 Analysis

- In case of problem, contact RJ distributor with the following information:
- Model, version and serial number of the product.
 - From the menu status:
 - Software version
 - LED board IDs
 - Device hours
 - Description of the problem.



6.3 Electronic thermal management system

In case of overheating, light intensity will be reduced by the system.
Power reduction and temperature values are available by using a RDM protocol compatible device.

6.4 Firmware update



After updating your device with firmware V3.0, we strongly recommend that you update the source type (CCT) either to CW (Cold White) or WW (Warm White) by following the procedure described in the section below: **CCT selection**

CCT selection

Until now, the CCT of the LED source was not taken into account. From V3.0, your device will be automatically recognized as CW or WW source.

Devices shipped with firmware prior to V3.0 do not have a designated CCT.
After updating to V3.0, it is highly recommended to specify the CCT of your device.
For this you will have to stay on the Web Page that you used for the update.

In the **Source** section of the HOME tab, the CCT of your device is indicated.

- If "unknown", please select the CCT of your device and click on icon **CW** or **WW** then on the arrow **>**.

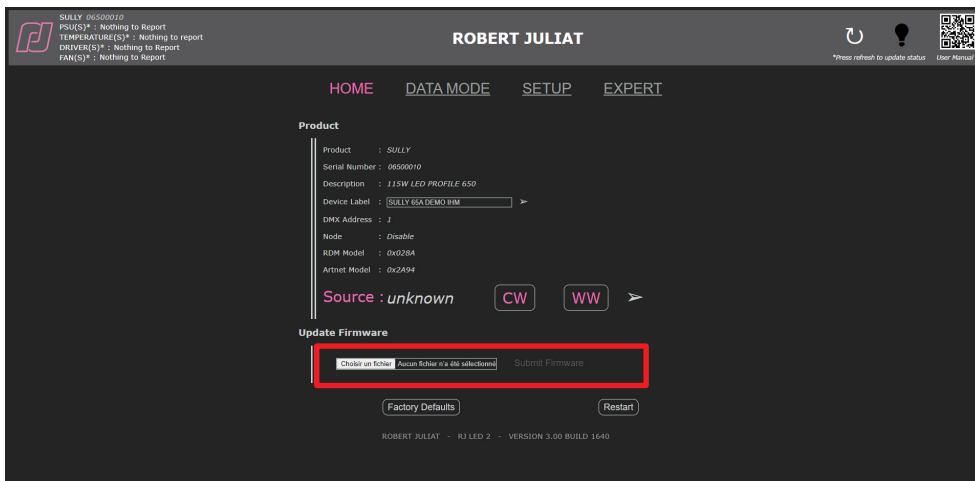

- Changing the source type changes the Model_ID as well. It is used in libraries to recognize devices automatically and for an Auto-Patch.
- If the source type has to be changed or in case of typing error, it will be always possible to change the source type in the Expert mode which is protected by a password.

1. Firmware available on www.robertjuliat.com/profilespots/SULLY_650SX
2. Download and unzip the file
There are 4 files:
 - Firmware (.upd2 format)
 - Firmware History
 - Update Procedure
 - User Manual from firmware V3.0
3. Switch on the unit
4. Connect Network from computer to the unit
5. Open a web browser (Internet Explorer, Firefox, Chrome...)
6. Enter the URL address to connect to the web interface (*see 5.1*)
7. Upload your firmware file (.upd2) in the "Update firmware" section and then click on 'Submit firmware'

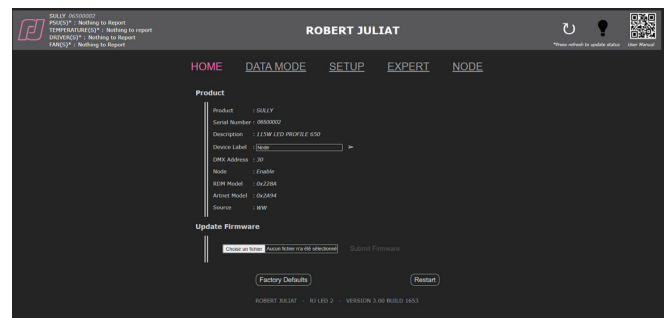

6.5 Factory defaults

6.5.1 Modes

Mode	Description
Restart	Software reset – all user parameters are kept
Factory defaults	Set all user parameters to factory default value

6.5.2 Control

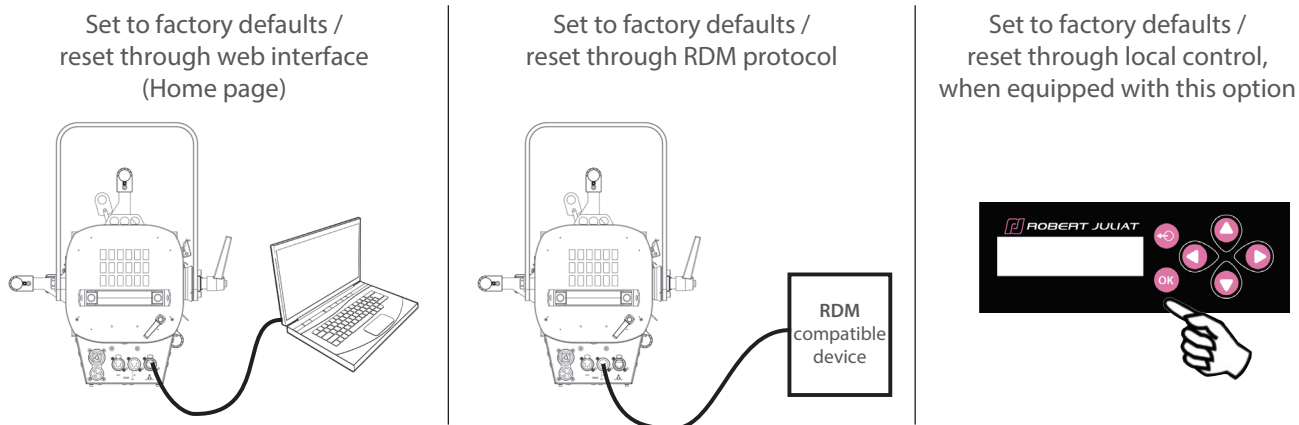

➔ If IP address unknown (due to a previous modification), IP address can be read from RDM protocol or a **hard reset** must be done:

