

SULLY

THE NEW CLASSICS
BY ROBERT JULIAT



T/6505X
T/16505X
LED MODULE



305LF / 305LPB
LED
SINGLE LENS LUMINAIRE



6505X
LED
PROFILE



1156
LED
FOLLOWSPOT



ROBERT JULIAT

UNCOMPROMISING QUALITY
SINCE 1919

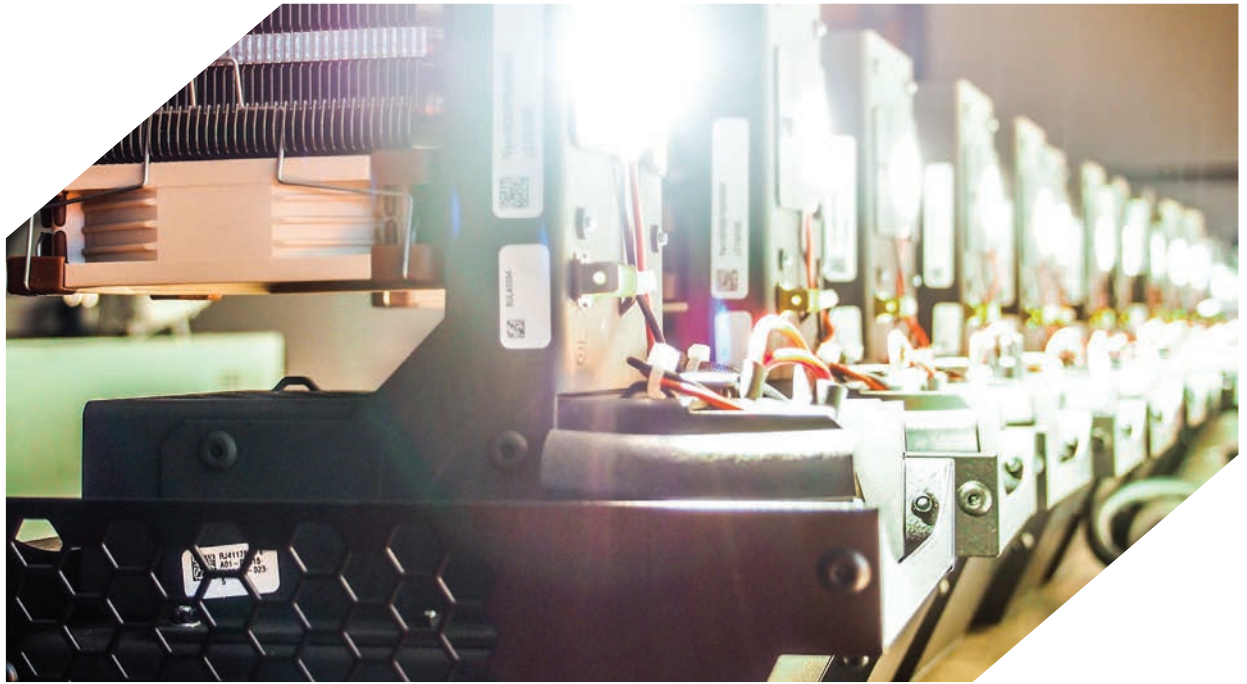

AN EFFICIENT LED SOURCE

Sully is a complete family of LED lighting fixtures which answers all needs (profile, single lens luminaire and followspot). It is also an LED module, housed in a single compartment, which allows the easy conversion of existing tungsten installations.

The common element in all the models of the Sully range is a new, high-quality 115W white LED source, which guarantees a light output equivalent to, or greater than, that of a 1000W tungsten lamp.

Available in two colour temperatures, cool white 5700K or warm white 3000K, Sully offers a very high quality of white light and high output for perfect daylight rendering, especially from the cool white source.

At a time when lighting inventories in venues and rental companies are undergoing major changes, this new range offers quality solutions with a solid guarantee of durability.

Most particularly, the Sully compartment provides a reliable and affordable transition from traditional sources to LED. As venues take gradual steps in changing and updating their lighting equipment, Sully makes it possible to standardise the equipment in venues already equipped with Robert Juliat luminaires. Sully ensures a uniformity and consistency in the quality of light throughout the progressive changes, allowing a smooth conversion, even while venues work with both conventional tungsten spots and the new LED spots.

As a result, Sully luminaires are becoming the new classics.

Colour Rendition Report ANSI/IES TM-30-18

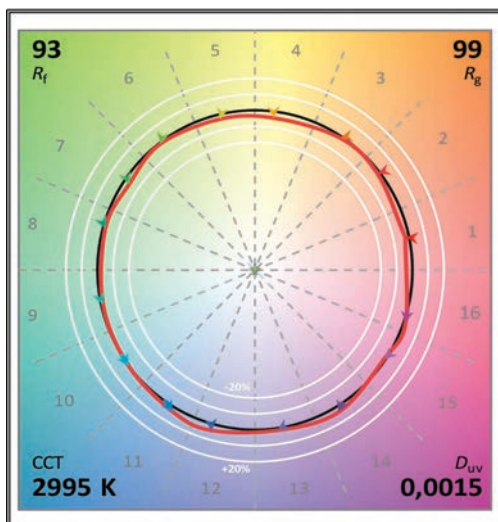

CRI - Colour Rendering Index CIE

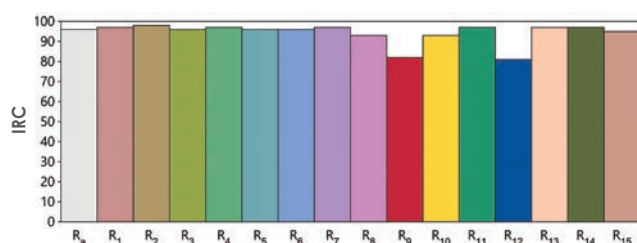

Spectral distribution

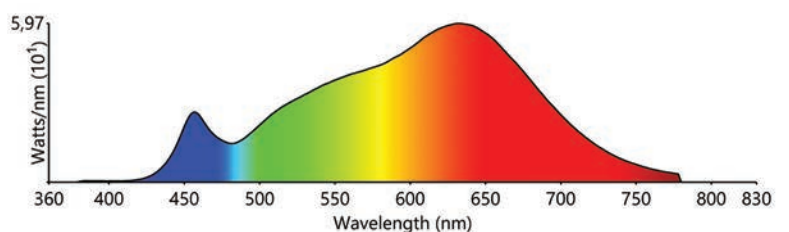

Results achieved using a **warm white** 654SX profile.



SULLY T650SX / T1650SX Compartment

For conversion of tungsten profiles or followspots

The Sully compartment is an ideal economic and technological solution for all those who own 600SX tungsten fixtures and wish to **convert them to LED profiles, while keeping the same optics, lantern body and accessories.**

Mounting the Sully compartment is quick and easy. This module is also compatible with the Aledin, Figaro and Quincy profiles and the tungsten Cricket and MSD Buxie followspots.

Replacing a tungsten lamp base with an LED compartment allows the body of the profile and all its optics - the quality and robustness of which have been proven over decades - to be retained and reused.

All existing accessories (iris, gobo holders, etc...) remain compatible in the LED conversion.

Energy consumption is greatly reduced, as are the maintenance costs associated with the frequent replacement of traditional lamps.

In addition, all original tungsten compartments can be refitted to meet specific lighting design requirements, thereby ensuring a versatile profile kit at your disposal.

- Integrated electronics (connection to a direct mains supply - up to 22 fixtures from 16A)
- DMX and network control (Art-Net and sACN)
- Configuration via RDM and/or web interface
- Display and keyboard for local setup (in option)

Two models available :

- Sully **T/650SX** compartment → conversion of profiles
- Sully **T/1650SX** compartment (with potentiometer) → conversion of followspots



Standard compartment



Compartment with optional display/keyboard

Retrofit compatibility

Source	Profile	Followspot
HAL 1000/1200W	600SX (611SX – 613SX – 614SX)	Cricket (1116)
LED 85W	Aledin (631SX – 633SX – 634SX)	
CDM-T 150W	Figaro (441SX – 443SX – 444SX)	
CDM-T 250W	Figaro (451SX – 453SX – 454SX)	
HID 575W	Quincy (421SX – 423SX – 424SX)	Buxie (1124)
HID 700W	Pierrot (411SX – 413SX – 414SX)	Foxie (1114)

Installation of Sully compartment

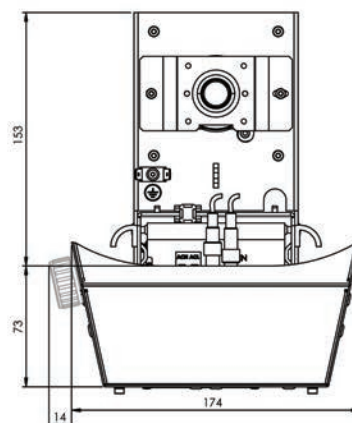
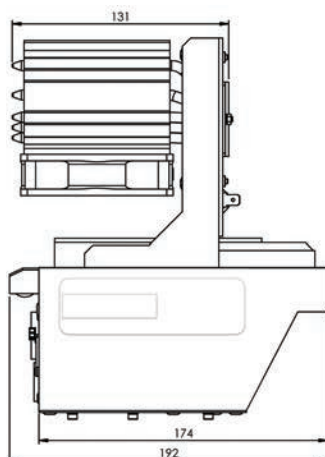

Dimensions in mm.



SULLY 650SX – PROFILE



653SX | 28° - 54°



654SX | 16° - 35°



651SX | 11° - 26°

Sully 650SX is a series of variable-zoom profiles that guarantees a first-class white light. It features an exceptional output - the cool white version output exceeding a 2500 W tungsten luminaire equipped with CTB filter, and the warm white version nearly matching that of 1200W tungsten models.

The LED compartment of the Sully profile can be interchanged with those of the 600SX, Aledin 630SX and Quincy 420SX.

Sully is a perfect profile for opera houses, theatres and TV studios, whether in grid, side booms or front-of-house positions.

- Extremely quiet operation
- SX series features (dual condenser optics, sharp and accurate framing, excellent image projection, variable zoom, shutter lock for up to 8 shutters)
- Electronic dimming from 0 to 100%, 8 or 16 bit control
- High quality whites
- Choice of dimming curves
- Adjustable response time
- Optional coated double condenser optics: up to 15% more light output
- Display and keyboard for local setup (in option)

COMPARISON OF TOTAL LUMEN OUTPUT (LUMENS) - ZOOM OPTICS AT 15°

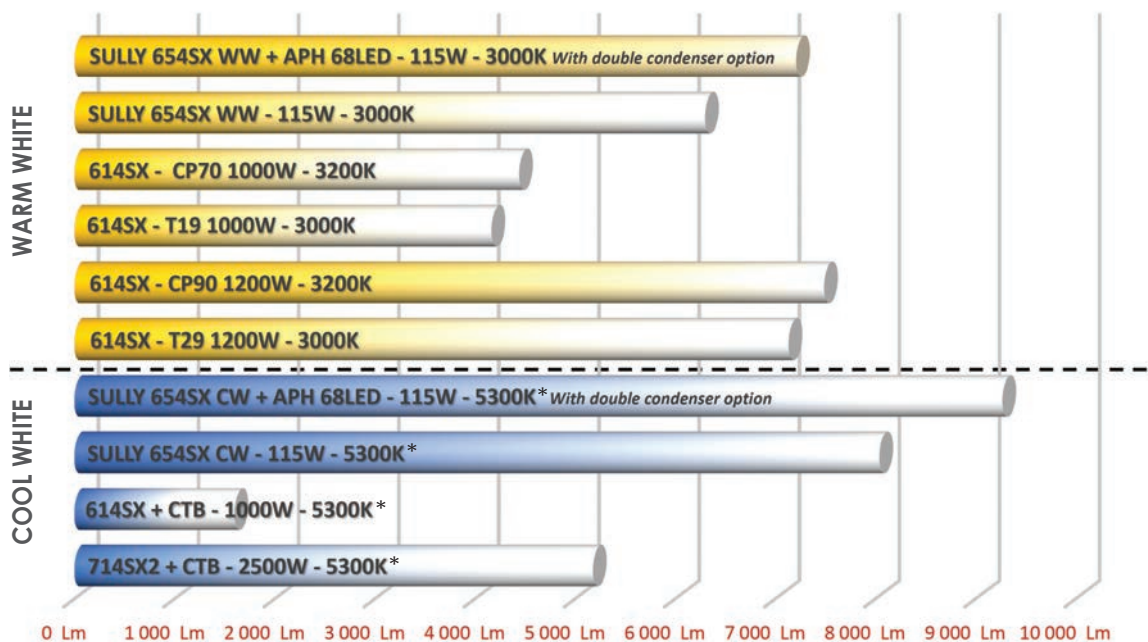

(*) Colour temperature value measured at luminaire output.



SULLY 305L - SINGLE LENS SPOT



305LF | Fresnel Lens



305LPB | Pebble Lens

Strongly inspired by the Lutin 306L 1000W tungsten, the Sully 305L offers a modernised version of this small multifunctional spotlight.

It is equipped with a 150 mm Fresnel or Pebble Convex lens, which are easily interchangeable. It therefore brings real added value to multi-purpose rooms and rental companies.

Offering a smooth flat-field beam and high quality colour rendering, it is an affordable and compact luminaire without compromise on quality and performance.

- LED / Tungsten compartment backward compatibility not possible
- Newly designed front cassette facilitating easy **interchange of lenses**
- Rotating barn door with 4 movable shutters and filter holder
- Graduated scale with index for easy marking of the beam aperture
- Display and keyboard for local setup (in option)



SULLY 1156 FOLLOWSPOT

Sully 1156 is a perfect introduction to the quality of Robert Juliat LED followspots for schools, cabarets or small venues.

With its ultra compact size, very low power consumption and excellent optical qualities, Sully is reliable and easy to use.

Available in warm white or cool white, Sully 1156 is capable of providing a light output comparable to 1000W tungsten sources, without the inconvenience and discomfort to the operator caused by tungsten heat generation.

With the ability to be controlled locally or remotely by DMX, this small followspot is undeniably accessible to everyone, from the novice user to the experienced followspot operator.

- Light intensity adjustment by potentiometer and by DMX
- 100% closing iris
- Variable optical zoom
- 6-ways push/pull colour changer
- Gobo holder
- Optional coated double condenser optics: up to 15% more light output
- Display and keyboard for local setup (in option)



1156 | 10.5° - 22.5°

TECHNICAL FEATURES

Fixture category	Single Lens Spot				Profile Spot						Followspot	
	Model	305LF WW	305LF CW	305LPB WW	305LPB CW	651SX WW	651SX CW	653SX WW	653SX CW	654SX WW	654SX CW	1156WW
Optics	Fresnel lens 150 mm		Pebble lens 150 mm		11/26°		28/54°		16/35°		10.5/22.5°	
SOURCE												
Type of source	115 W white LED											
Colour temperature	3000 K	5700 K	3000 K	5700 K	3000 K	5700 K	3000 K	5700 K	3000 K	5700 K	3000 K	5700 K
Lumen Output	11400 Lm	14300 Lm	11400 Lm	14300 Lm	11400 Lm	14300 Lm	11400 Lm	14300 Lm	11400 Lm	14300 Lm	11400 Lm	14300 Lm
CRI	98	93	98	93	98	93	98	93	98	93	98	93
ELECTRONICS												
Type of power supply unit	Electronic											
Voltage / Frequency	90 → 277 V 50/60 Hz											
Power consumption	130 W											
Max. number of units (230V)	22											
Power thru	Neutrik powerCON TRUE1 TOP											
Cooling	Low noise variable fan											
Control	Compatible DMX 512-A / RDM / sACN / Art-Net											
Data IN connector	5 pins XLR male + etherCON RJ45											
Data OUT connector	5 pins XLR female											
Noise level	24.00dB(A)				22.80dB(A)				22.80dB(A)			
PHOTOMETRICS												
Minimum zoom												
Field angle (3%)	17°	15°	29°	30°	11°	11°	28°	28°	16°	18°	12°	11°
Beam angle (50%)	9°	8°	18°	18°	9°	9°	22°	23°	15°	16°	10°	10°
Field lumens	1870 Lm	2710 Lm	2520 Lm	2850 Lm	5900 Lm	7500 Lm	6450 Lm	8530 Lm	6300 Lm	8040 Lm	4290 Lm	5450 Lm
Efficacy	15 Lm/W	21 Lm/W	20 Lm/W	22 Lm/W	45 Lm/W	57 Lm/W	49 Lm/W	65 Lm/W	48 Lm/W	61 Lm/W	29 Lm/W	37 Lm/W
Illumination at a 5 m distance	4050 Lux	4950 Lux	850 Lux	900 Lux	-	-	2300 Lux	2950 Lux	6000 Lux	6500 Lux	7900 Lux	-
Illumination at a 10 m distance	1050 Lux	1250 Lux	220 Lux	230 Lux	3350 Lux	4150 Lux	570 Lux	740 Lux	1500 Lux	1650 Lux	2000 Lux	2800 Lux
Maximum zoom												
Field angle (3%)	93°	89°	98°	104°	23°	23°	50°	50°	34°	33°	22°	23°
Beam angle (50%)	57°	67°	68°	66°	17°	16°	30°	33°	23°	22°	17°	16°
Field lumens	8630 Lm	10420 Lm	10350 Lm	13150 Lm	6330 Lm	7780 Lm	7520 Lm	9600 Lm	6420 Lm	8760 Lm	4380 Lm	5130 Lm
Efficacy	67 Lm/W	81 Lm/W	80 Lm/W	102 Lm/W	48 Lm/W	59 Lm/W	57 Lm/W	72 Lm/W	49 Lm/W	66 Lm/W	30 Lm/W	25 Lm/W
Illumination at a 5 m distance	350 Lux	390 Lux	210 Lux	230 Lux	3600 Lux	4600 Lux	1050 Lux	1250 Lux	1850 Lux	2800 Lux	2600 Lux	3050 Lux
Illumination at a 10 m distance	90 Lux	100 Lux	51 Lux	60 Lux	900 Lux	1150 Lux	260 Lux	310 Lux	460 Lux	700 Lux	650 Lux	760 Lux
LIGHT QUALITY REPORT												
CCT	3060 K	5660 K	3090 K	5710 K	2980 K	5040 K	2990 K	5180 K	3000 K	5360 K	3040 K	5370 K
Delta UV	-0.001	0.003	0.002	0.001	0.003	0.004	0.003	0.004	0.002	0.003	0.000	0.000
CRI Colour Rendering Index	98	95	96	97	96	95	96	96	97	96	-	-
Colour Rendillon TM30-Rf	93	92	93	92	93	92	93	93	93	92	93	92
Colour Rendillon TM30-Rg	99	102	99	103	98	102	98	102	99	102	99	102
TLCI - Television Lighting Consistency Index	97	90	97	90	97	89	97	90	97	89	97	90
DIMENSIONS (in mm)												
H	387	387	387	387	463	463	463	463	463	463	387	387
H1	212	212	212	212	208	208	208	208	208	208	208	208
H2	-	-	-	-	284	284	284	284	284	284	284	284
L	423	423	423	423	782	782	564	564	696	696	928	928
L1	231	231	231	231	240	240	240	240	240	240	411	411
L2	192	192	192	192	542	542	324	324	456	456	517	517
W	304	304	304	304	330	330	330	330	330	330	327	327
W1	208	208	208	208	208	208	208	208	208	208	233	233
W2	-	-	-	-	136	136	136	136	136	136	472	472
Y	283	283	283	283	280	280	280	280	280	280	283	283
Standard filler holder	180x180 mm (7.1x7.1 in)				180x180 mm (7.1x7.1 in)						165 mm (6.5 in)	
Optional filler holder	-				185x185 mm (7.3x7.3 in)						-	
Weight (kg)	8,5	8,5	8,8	8,8	13,9	13,9	12,2	12,2	13,6	13,6	15,6	15,6

DMX CHART

Channel	Mode 1	Mode 2	Mode 3	Mode 4	Mode 5*	Mode 6*
1	Dimmer	Dimmer	Dimmer	Dimmer	Dimmer	Dimmer
2		Dimmer fine	Strobe duration	Dimmer fine	Master dimmer	Dimmer fine
3			Strobe speed	Strobe duration	Strobe duration	Master dimmer
4			Response time	Strobe speed	Strobe speed	Master dimmer fine
5			Control mode	Response time	Response time	Strobe duration
6				Control mode	Control mode	Strobe speed
7						Response time
8						Control mode

(* Mode only available for the followspot - Please refer to the User Manual to read the entire DMX Chart information.

Robert Juliat - 32, rue de Beaumont - 60530 Fresnoy-en-Thelle - FRANCE | +33 (0)3 44 26 51 89 | info@robertjuliat.fr

Non-contractual photos. Reproduction is prohibited without written permission from Robert Juliat.
Robert Juliat reserves the right to modify the content of this brochure or the characteristics of its products without prior notice.